

56081

# WHITE NEPTUNE TRIPLE SLEEPER ASSEMBLY INSTRUCTIONS



100KG  
TOP BUNK  
MAX WEIGHT



180KG  
BOTTOM BUNK  
MAX WEIGHT

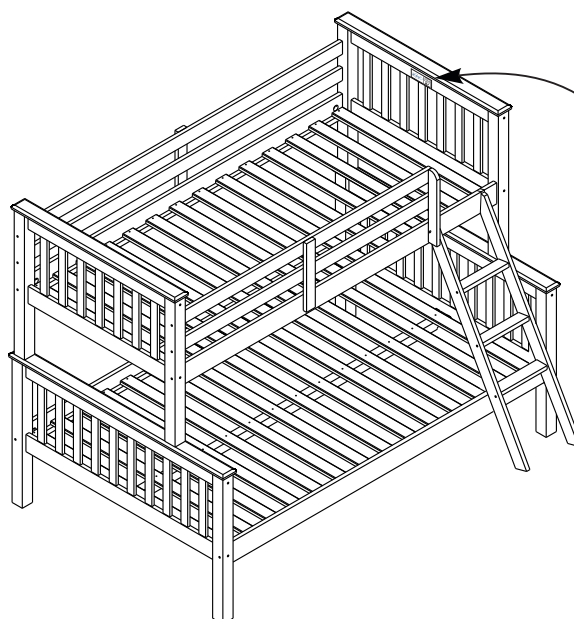

## IMPORTANT FOR DOMESTIC USE ONLY

PLEASE READ AND FOLLOW THESE INSTRUCTIONS CAREFULLY

## RETAIN FOR FUTURE REFERENCE CARE AND MAINTENANCE

**WARNING** “High beds and the upper bed of bunk beds are not suitable for children under the age of six years due to the risk of injury from falls”.

**WARNING** “Bunk beds and high beds can present a serious risk of injury from strangulation if not used correctly. Never attach or hang items to any part of the bunk bed that are not designed to be used with the bed, for example, but not limited to; ropes, strings, cords, hooks, belts and bags”.

**WARNING** “Children can become trapped between the bed and the wall, a roof pitch, the ceiling, adjoining pieces of furniture (e.g. cupboards) and the like. To avoid risk of serious injury the distance between the top safety barrier and the adjoining structure shall not exceed 75mm or shall be more than 230mm”.

**WARNING** Do not use the bunk bed/high bed if any structural part is broken or missing.

The recommended mattress size for this bunk bed is 1900mm x 915mm x 150mm.

The maximum mattress height is 160mm.

The maximum mattress height is clearly marked on the bunk bed and **MUST NOT BE EXCEEDED**.

Depending on the amount of use this product receives it may be necessary to tighten up the fixings from time to time, this is completely normal for all flat pack furniture. **DO NOT OVER TIGHTEN FIXINGS**. Do not for any reason use a power tool to assemble this product.

Two persons are required to assemble this bunk bed.

Assemble as close to its final position as possible.

Assemble on a soft clean surface.

For cleaning you may use a damp cloth (not wet).

The room in which the bed is positioned should be ventilated to prevent mould in and around the bed.

This bunk bed is manufactured to conform to BS EN 747:2012+A1:2015

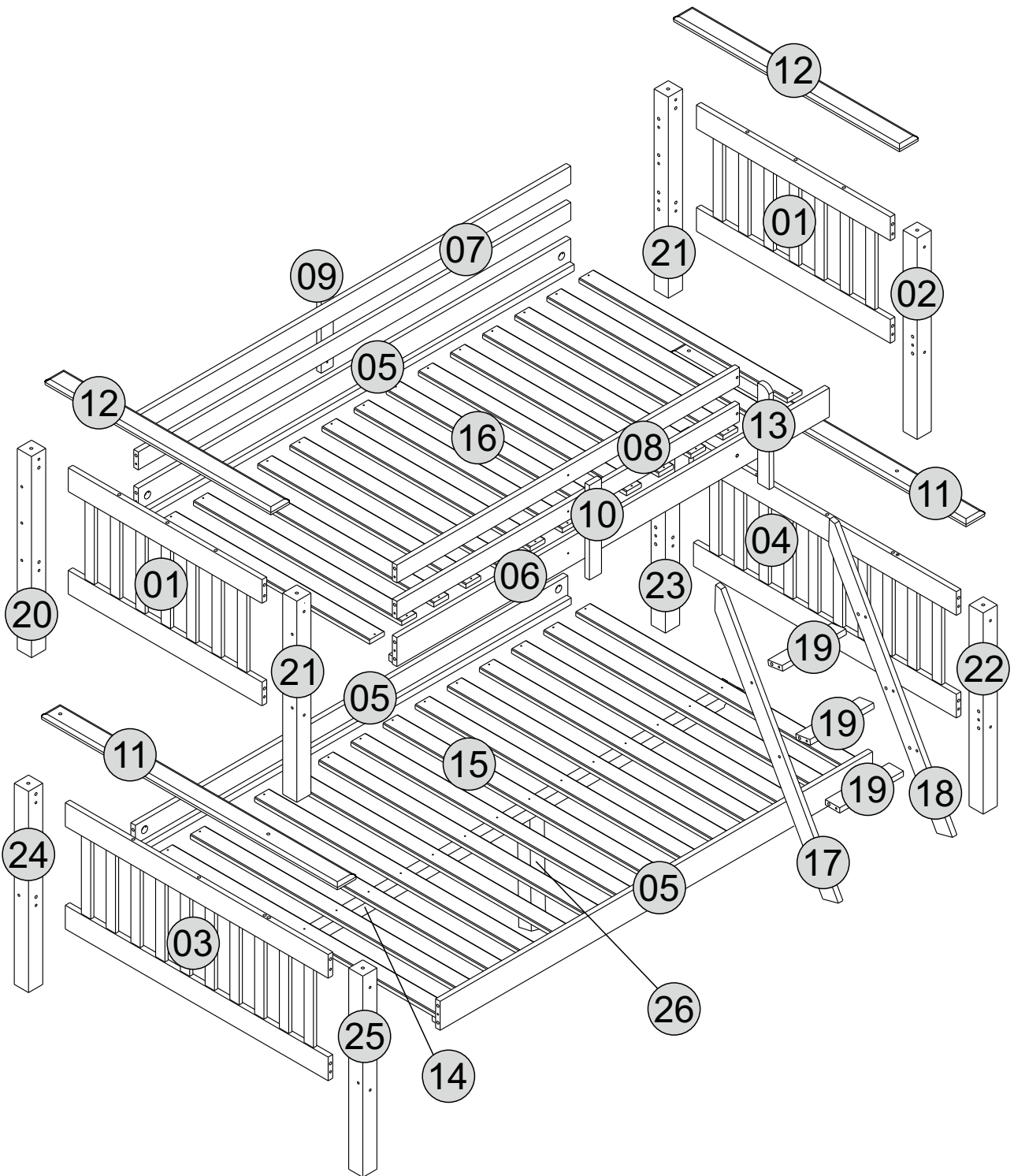













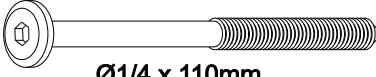

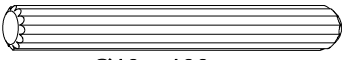

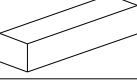

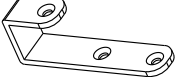
\* Use of power tools to assemble this product will invalidate any claim and damage this product making it unsafe !!!  
\* Please assemble on a clean soft surface to avoid damage.

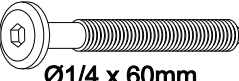
\* Please check contents and read the instructions before commencing assembly.  
\* Assemble this product following the enclosed instructions carefully.  
\* Please take care to avoid damaging panels during assembly.

## PARTS LIST

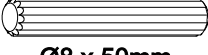
Part Number	Part Code	Part Description	Quantity	Carton
01	S200-205-011-DC1-01	Upper Headboard Panel	2	1/3
02	S200-205-011-DC1-02	Upper Right Headboard Post (Natural)	1	1/3
03	S200-205-011-DC1-03	Lower Left Headboard Panel	1	2/3
04	S200-205-011-DC1-04	Lower Right Headboard Panel	1	2/3
05	S200-205-011-DC1-05	Side Rail	3	3/3
06	S200-205-011-DC1-06	Top Front Side Rail	1	3/3
07	S200-205-011-DC1-07	Long Safety Rail	2	3/3
08	S200-205-011-DC1-08	Short Safety Rail	2	3/3
09	S200-205-011-DC1-09	Back Support Brace	1	3/3
10	S200-205-011-DC1-10	Front Support Brace	1	3/3
11	S200-205-011-DC1-11	Bottom Headboard Plinth	2	2/3
12	S200-205-011-DC1-12	Top Headboard Plinth	2	2/3
13	S200-205-011-DC1-13	Ladder Support Brace	1	2/3
14	S200-205-011-DC1-14	Centre Support Rail	1	3/3
15	S200-205-011-DC1-15	4' Slats	14	2/3
16	S200-205-011-DC1-16	3' Slats	14	1/3
17	S200-205-011-DC1-17	Left Ladder Section	1	2/3
18	S200-205-011-DC1-18	Right Ladder Section	1	2/3
19	S200-205-011-DC1-19	Ladder Step	3	2/3
20	S200-205-011-DC1-20	Upper Left Back Headboard Post (Grey)	1	1/3
21	S200-205-011-DC1-21	Upper Right/Left Headboard Post (Red)	2	1/3
22	S200-205-011-DC1-22	Lower Right Headboard Post (Purple)	1	1/3
23	S200-205-011-DC1-23	Lower Left Headboard Post (Brown)	1	1/3
24	S200-205-011-DC1-24	Lower Left Headboard Post (Orange)	1	1/3
25	S200-205-011-DC1-25	Lower Right Headboard Post (Pink)	1	1/3
26	S200-205-011-DC1-26	Centre Support Leg	1	2/3

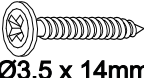
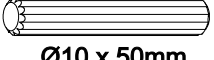
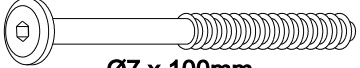
### FITTINGS

A	 Ø1/4 x 110mm	08	K		03
B	 1/4	08	L	 Ø10 x 100mm	04
C	 Ø7 x 50mm	03	M		02
D	 3,5 x 35mm	70	N		02
E	 Allen key	01	O	 Ø4,0 x 35mm	12
F	 Ø1/4 x 60mm	02	P		02
G	 1/4"	02	Q		01
H	 Ø8 x 50mm	56	R	 Ø7 x 90mm	01
I	 Ø3,5 x 14mm	18	S	 Ø10 x 50mm	06
J	 Ø7 x 100mm	22	T	 Ø4,0 x 25mm	06

### TOOLS REQUIRED

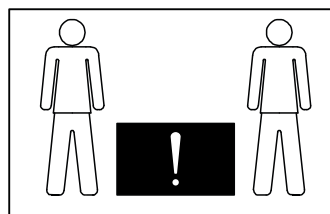
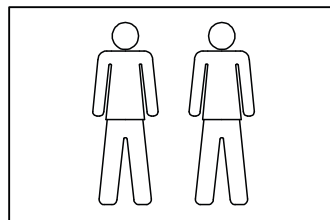
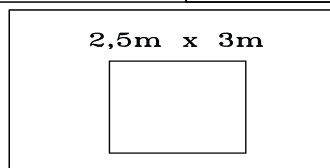
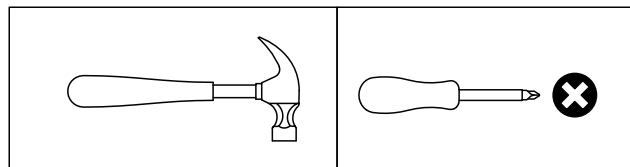

# STEP 1

## PARTS REQUIRED

03- LOWER LEFT HEADBOARD PANEL x1

04- LOWER RIGHT HEADBOARD PANEL x1

## HARDWARE REQUIRED

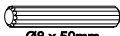
H  14  
Ø8 x 50mm

K  01  
GLUE

## TOOLS REQUIRED

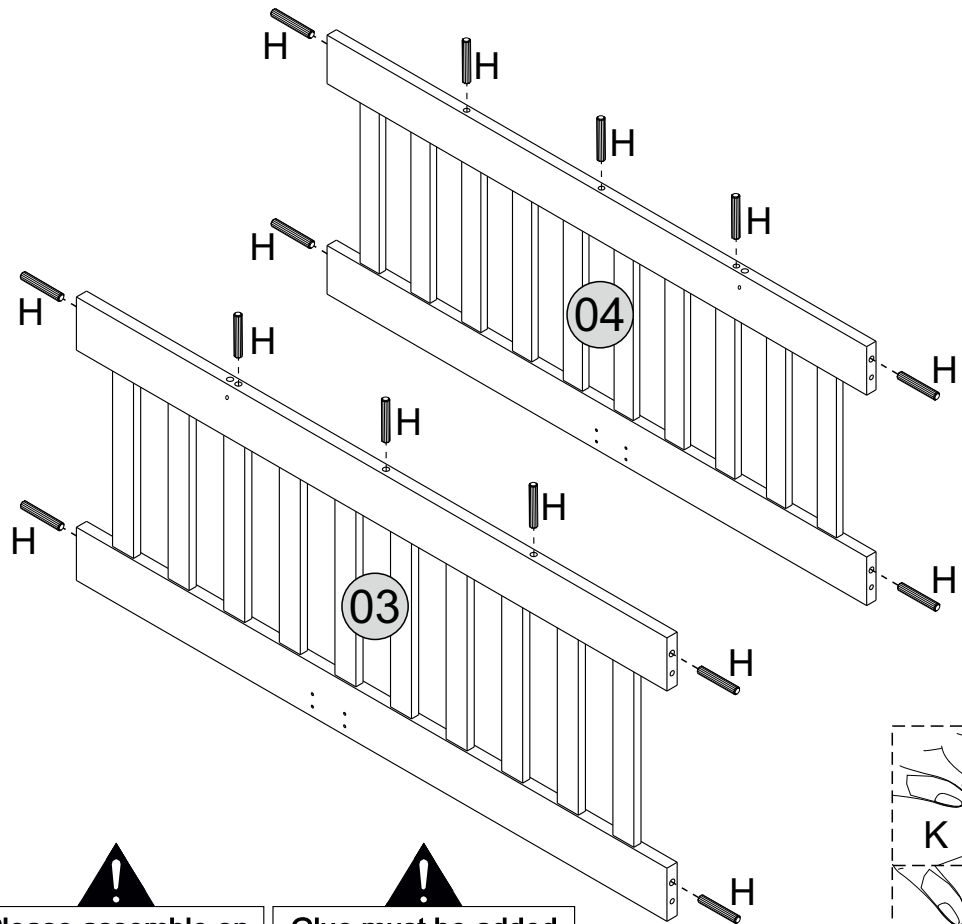

**!**  
Please assemble on a clean soft surface to avoid damage.

**!**  
Glue must be added to the dowel holes on part 03 and 04.

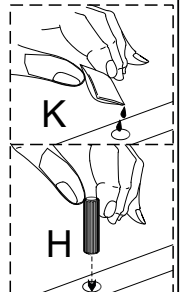

# STEP 2

## PARTS REQUIRED

03- LOWER LEFT HEADBOARD PANEL x1

24- LOWER LEFT HEADBOARD POST (ORANGE) X1

25- LOWER RIGHT HEADBOARD POST (PINK) X1

## HARDWARE REQUIRED

H  01  
Ø8 x 50mm

J  04  
Ø7 x 100mm

K  01  
GLUE

## TOOLS REQUIRED

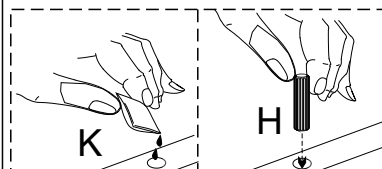
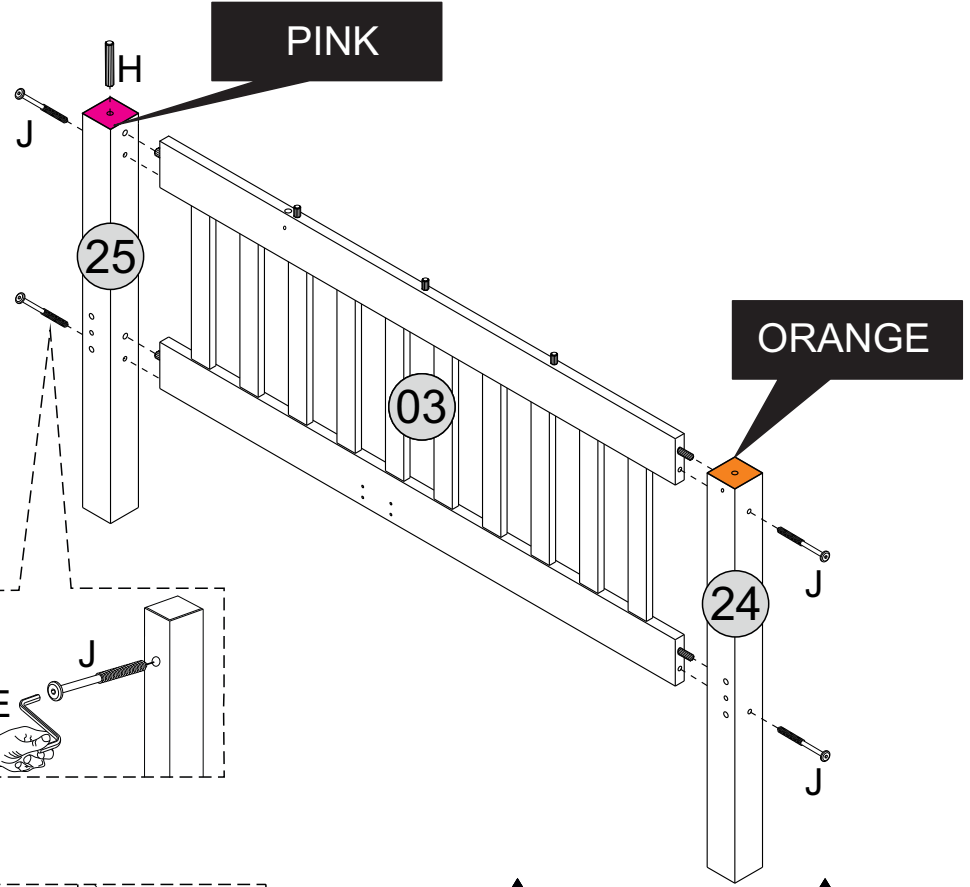
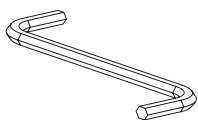

**!**  
Please assemble on a clean soft surface to avoid damage.

**!**  
Glue must be added to the dowel holes on part 24 and 25.

# STEP 3

## PARTS REQUIRED

04-LOWER RIGHT HEADBOARD PANEL X1

22- LOWER RIGHT HEADBOARD POST(PURPLE)x1

23-LOWER LEFT HEADBOARD POST (BROWN) X1

## HARDWARE REQUIRED

H  01  
Ø8 x 50mm

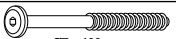
J  04  
Ø7 x 100mm

K  01

## TOOLS REQUIRED

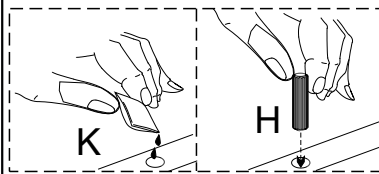
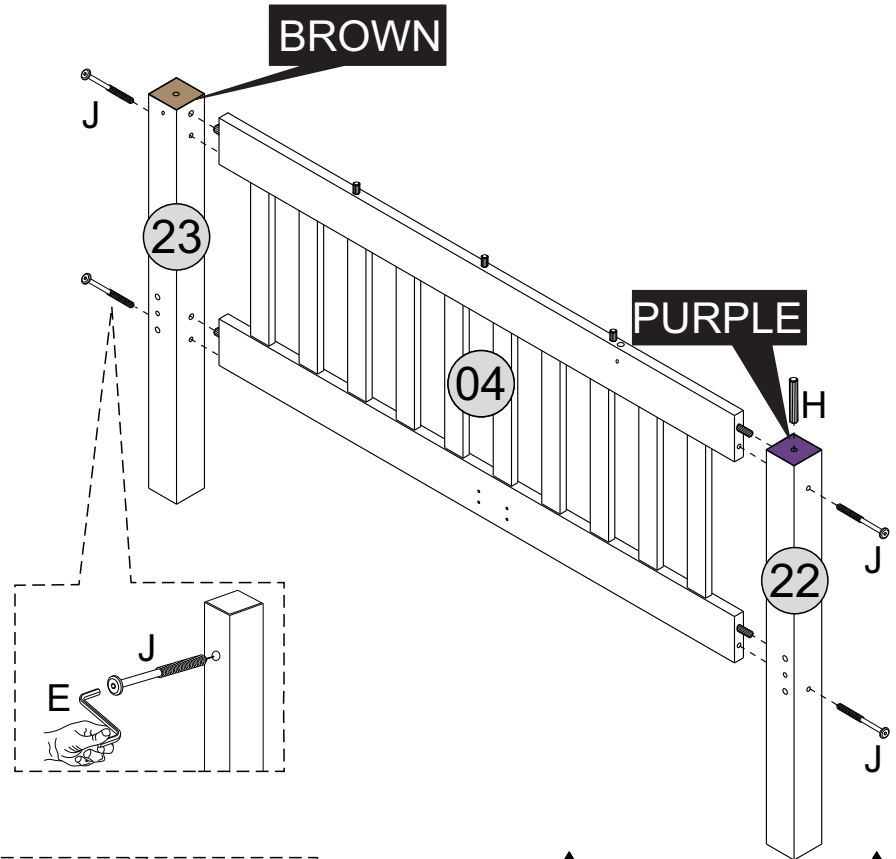
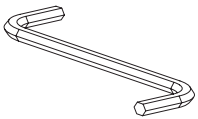

**!**  
Please assemble on a clean soft surface to avoid damage.

**!**  
Glue must be added to the dowel holes on part 22 and 23.

# STEP 4

## PARTS REQUIRED

01-UPPER HEADBOARD PANEL x2

## HARDWARE REQUIRED

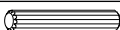
H  14  
Ø8 x 50mm

K  01

## TOOLS REQUIRED

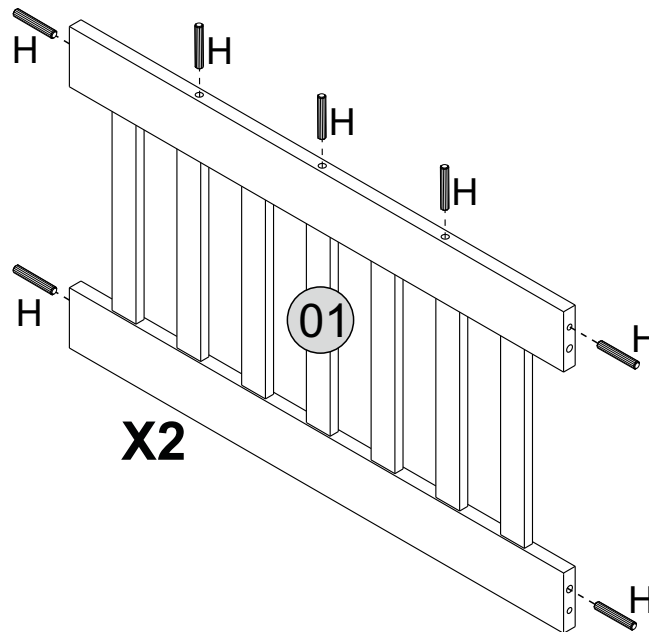

**!**  
Please assemble on a clean soft surface to avoid damage.

**!**  
Glue must be added to the dowel holes on part 01.

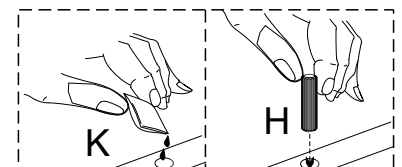



# STEP 5

## PARTS REQUIRED

- 01- HEADBOARD PANEL x1
- 02- UPPER RIGHT HEADBOARD POST (NATURAL) x1
- 21- UPPER RIGHT/LEFT POST (RED) x1

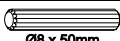
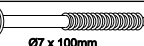
## HARDWARE REQUIRED

- H  02  
Ø8 x 50mm
- J  04  
Ø7 x 100mm
- K  01  
GLUE

## TOOLS REQUIRED

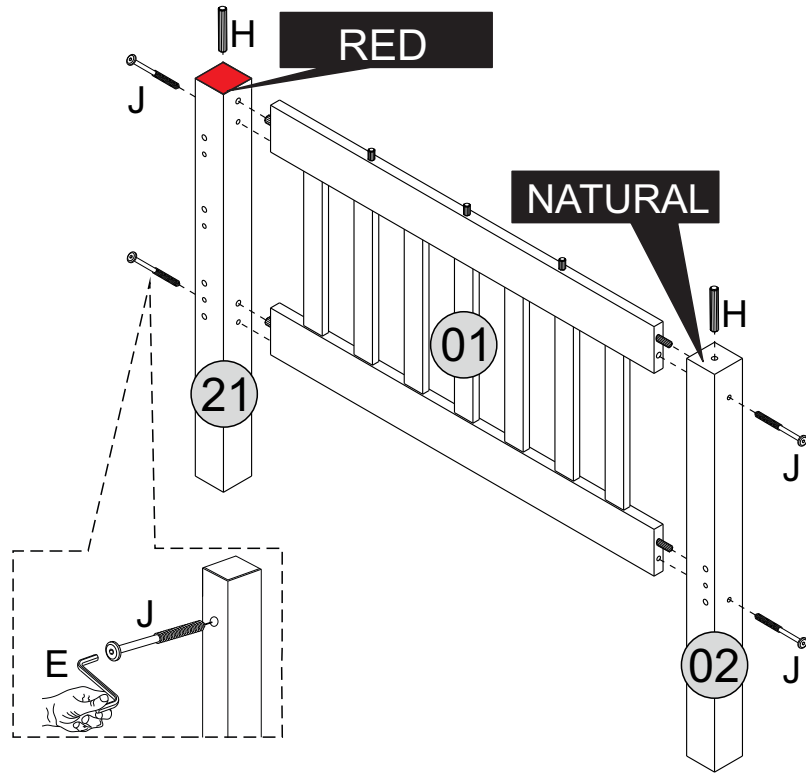
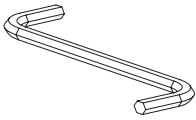

**!**  
Please assemble on a clean soft surface to avoid damage.

**!**  
Glue must be added to the dowel holes on part 02 and 21.





# STEP 6

## PARTS REQUIRED

- 01- HEADBOARD PANEL x1
- 20- UPPER LEFT BACK POST (GREY) x1
- 21- UPPER RIGHT/LEFT POST (RED) x1

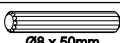
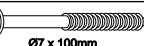
## HARDWARE REQUIRED

- H  02  
Ø8 x 50mm
- J  04  
Ø7 x 100mm
- K  01  
GLUE

## TOOLS REQUIRED

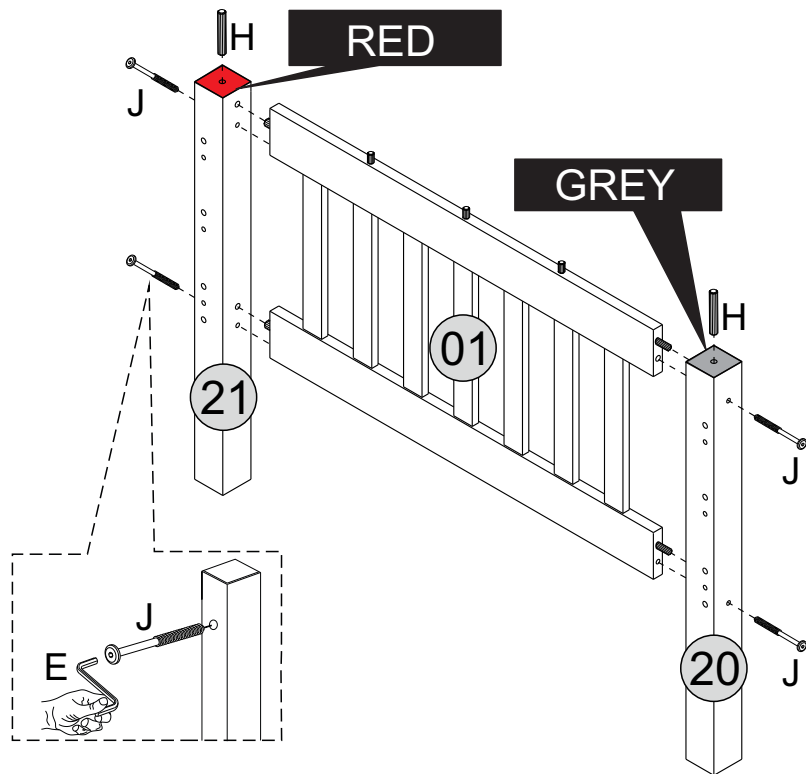
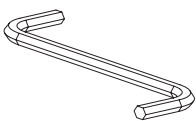

**!**  
Please assemble on a clean soft surface to avoid damage.

**!**  
Glue must be added to the dowel holes on part 20 and 21.

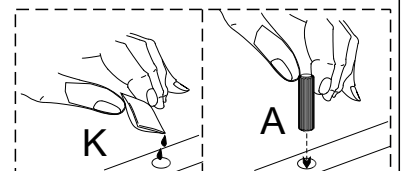

# STEP 7

## PARTS REQUIRED

05- SIDE RAIL	x3
06- TOP FRONT SIDE RAIL	x1
07- LONG SAFETY RAIL	x2
08- SHORT SAFETY RAIL	x2

## HARDWARE REQUIRED

H		22
---	---	----

## TOOLS REQUIRED

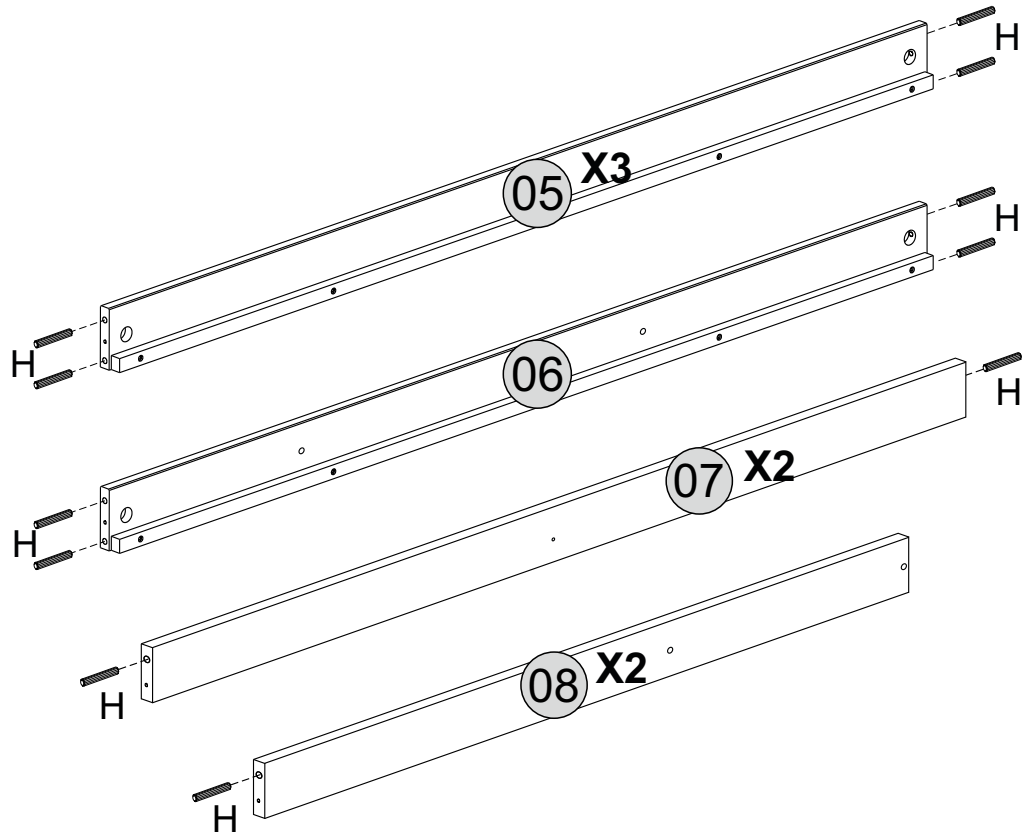



# STEP 8

## PARTS REQUIRED

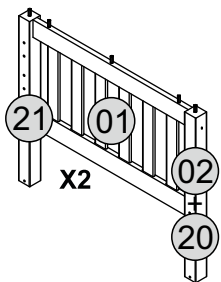
05- SIDE RAIL	x1
06- TOP FRONT SIDE RAIL	x1
07- LONG SAFETY RAIL	x2

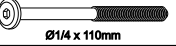

## HARDWARE REQUIRED

A		04
B		04
J		04

## TOOLS REQUIRED

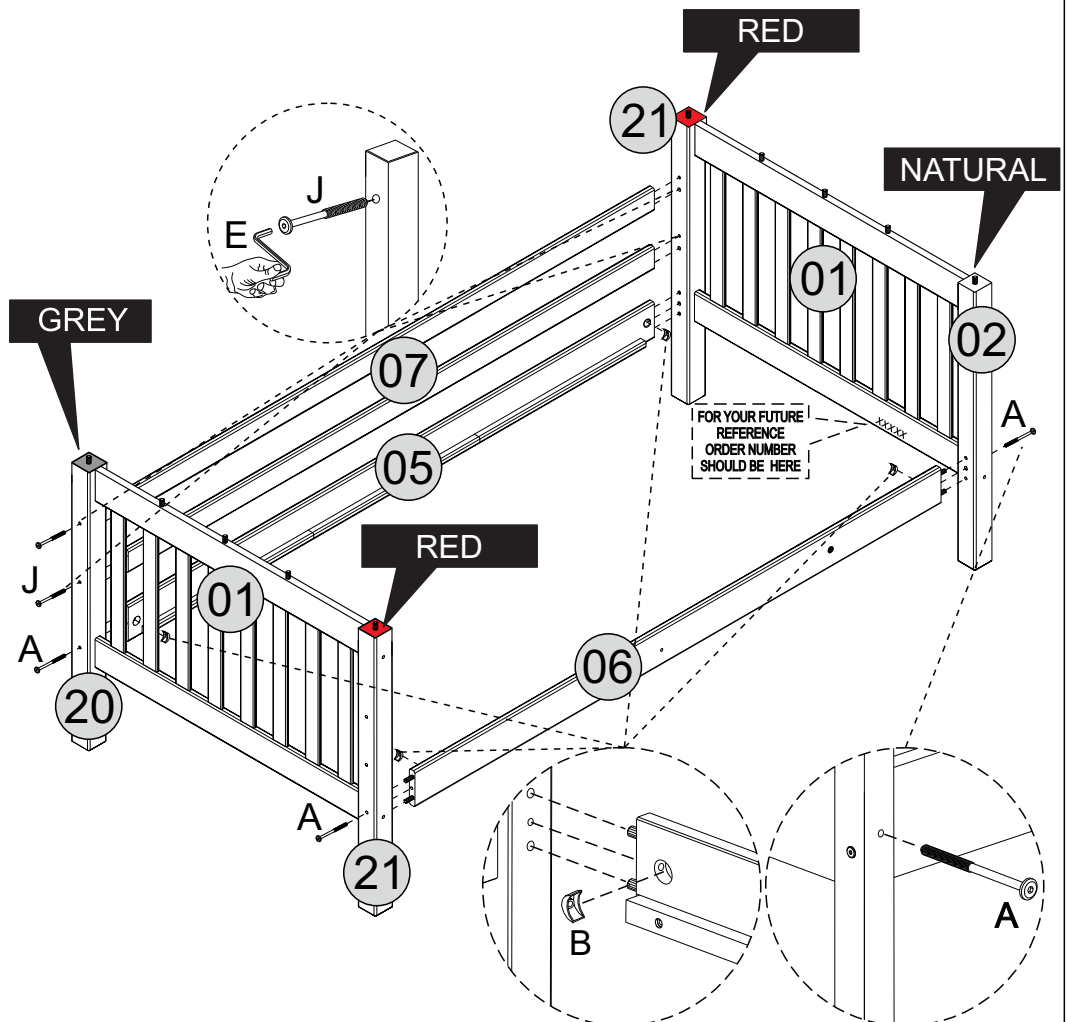
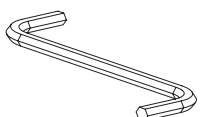



# STEP 9

## PARTS REQUIRED

12- TOP HEADBOARD PLINTH x2

13- LADDER SUPPORT BRACE x1

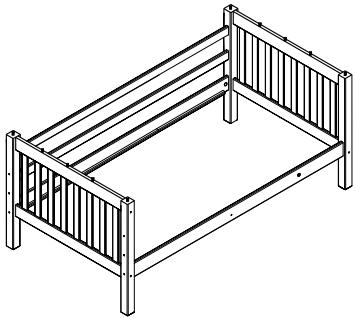

## HARDWARE REQUIRED

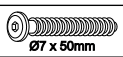
C  01  
Ø7 x 50mm

K  01  
GLUE

## TOOLS REQUIRED

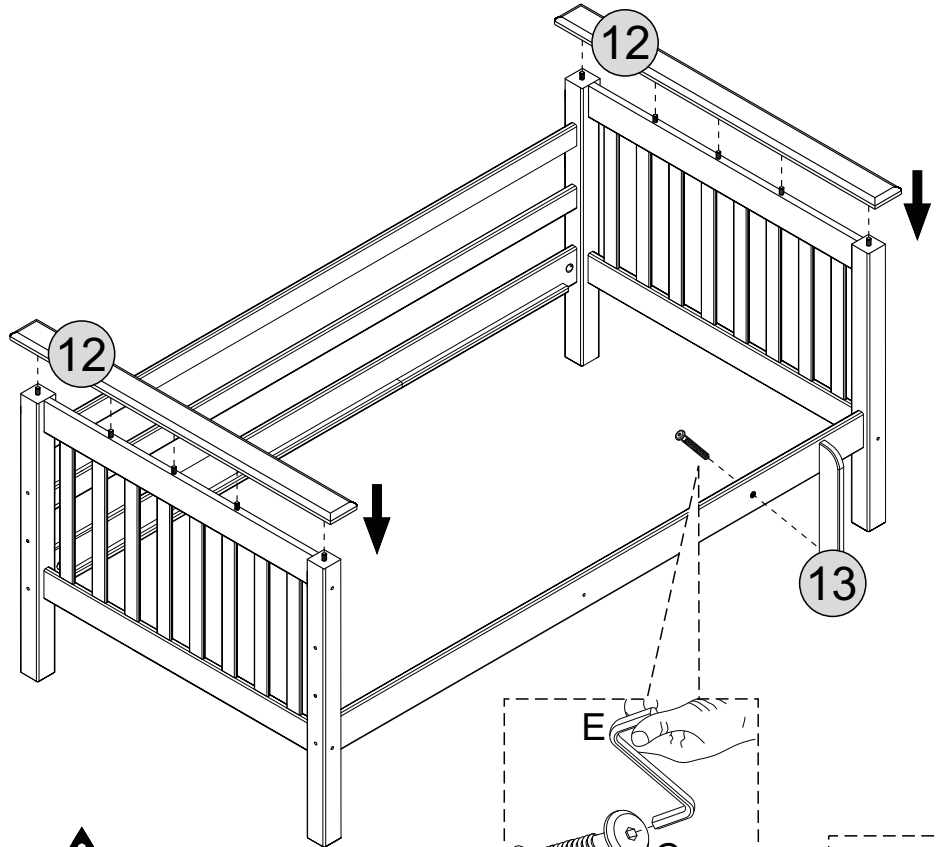
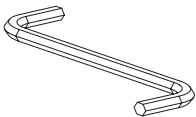

**!**  
Glue must be added to the dowel holes on part 12.

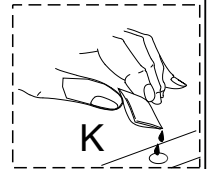
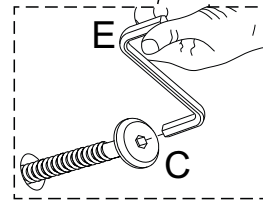

# STEP 10

## PARTS REQUIRED

08- SHORT SAFETY RAIL x2

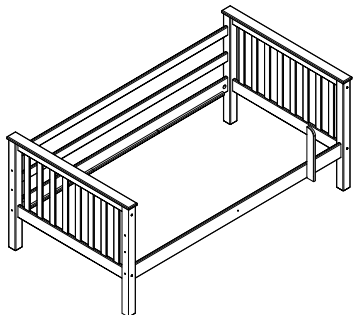

## HARDWARE REQUIRED

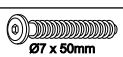
C  02  
Ø7 x 50mm

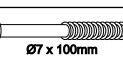
J  02  
Ø7 x 100mm

## TOOLS REQUIRED

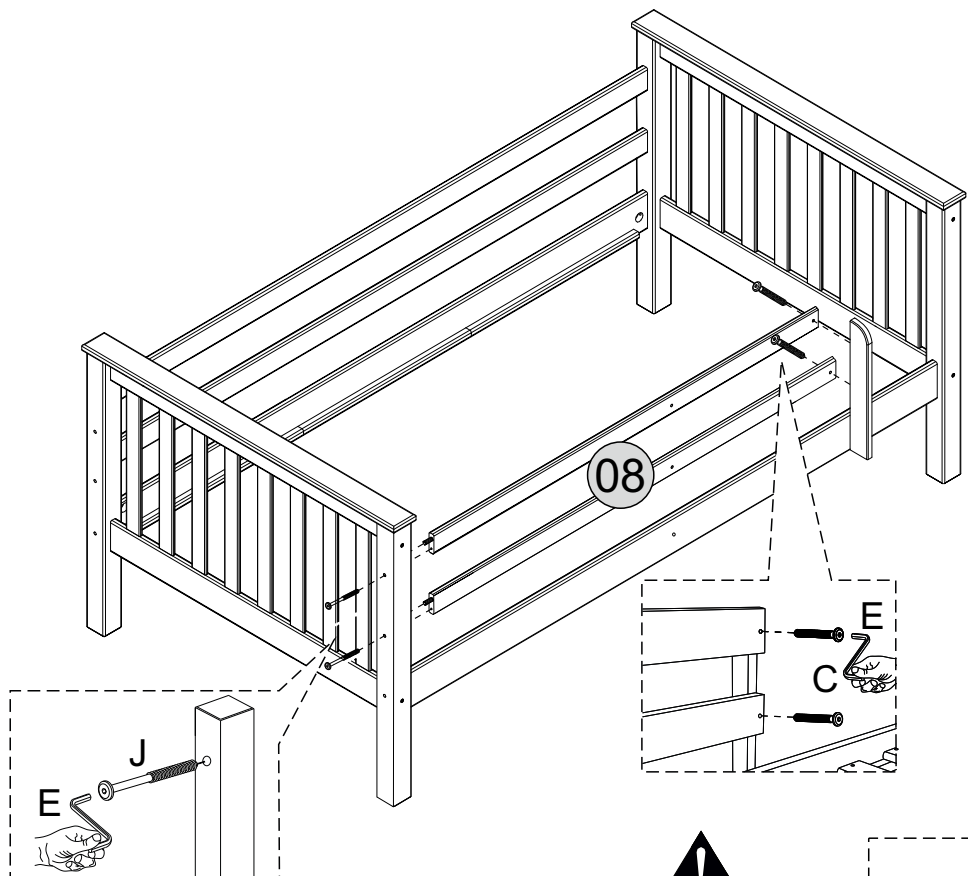
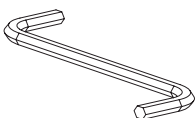

**!**  
Glue must be added to the dowel holes on part 21.

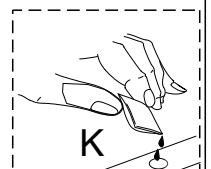
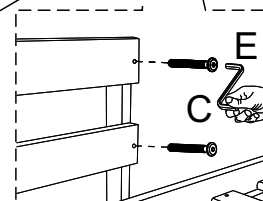
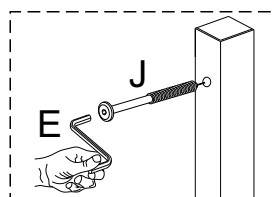

# STEP 11

## PARTS REQUIRED

09- BACK SUPPORT BRACE x1

10- FRONT SUPPORT BRACE x1

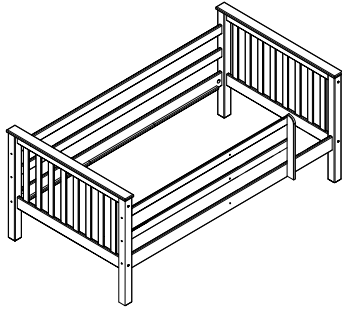

## HARDWARE REQUIRED

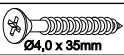
O  06  
Ø4,0 x 35mm

## TOOLS REQUIRED

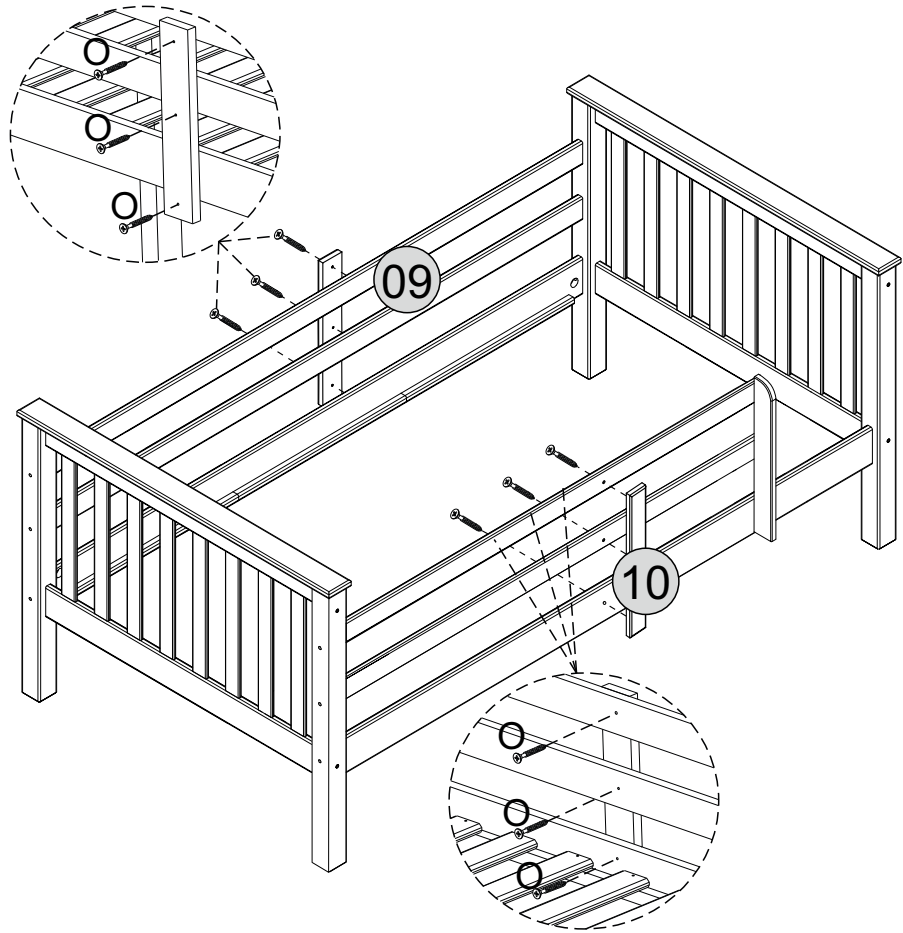
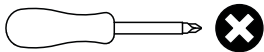

# STEP 12

## PARTS REQUIRED

16 - 3' SLATS x14

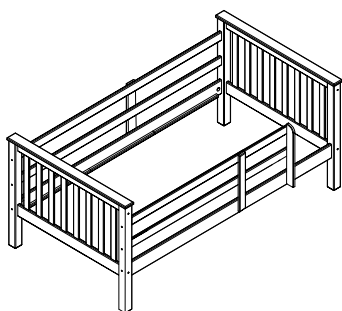

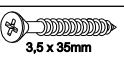

## HARDWARE REQUIRED

D  28  
3,5 x 35mm

M  02  
SPACER (WOODEN)

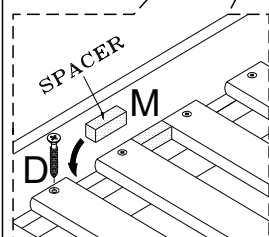
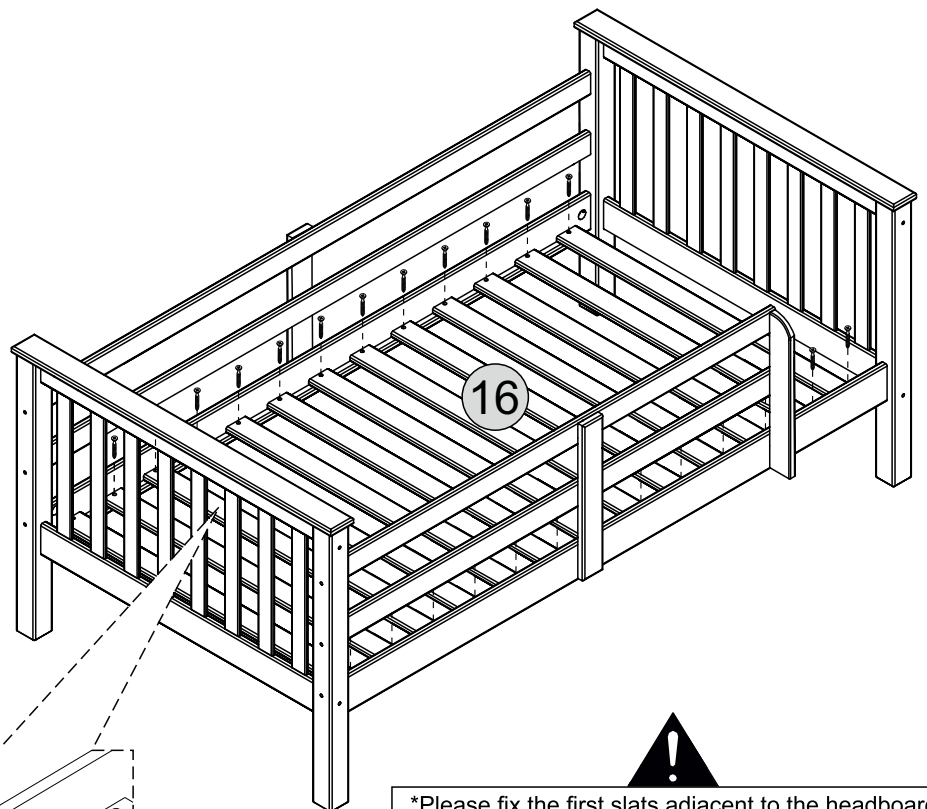
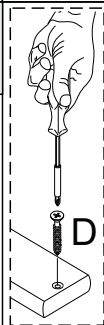
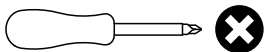
## TOOLS REQUIRED



 \*Please fix the first slats adjacent to the headboard and footboard and work towards the middle of the bed using the spacer (M) as shown to ensure correct spacing. Fix all the slats to one siderail first then push the opposite siderail tight against the slats and fix. Please retain the Allen Key (E) and use periodically to check that all bolts are tight.

# STEP 13

## PARTS REQUIRED

05- SIDE RAIL x2

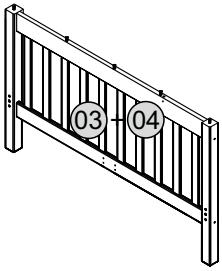

## HARDWARE REQUIRED

A  Ø1/4 x 110mm 04

B  1/4 04

I  Ø3,5 x 14mm 08

P  02

## TOOLS REQUIRED

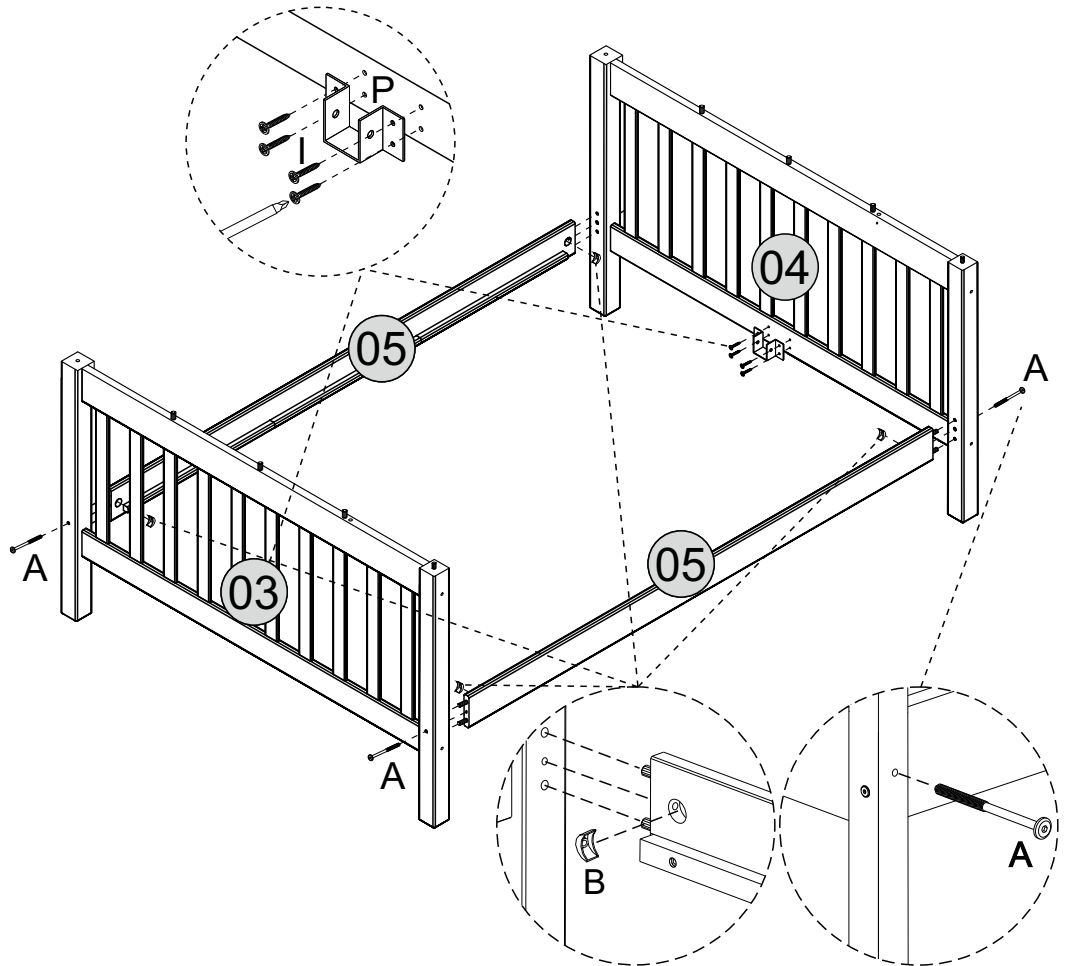
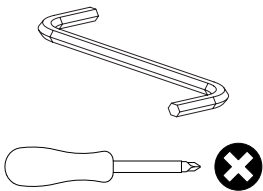

# STEP 14

## PARTS REQUIRED

11- BOTTOM HEADBOARD PLINTH x2

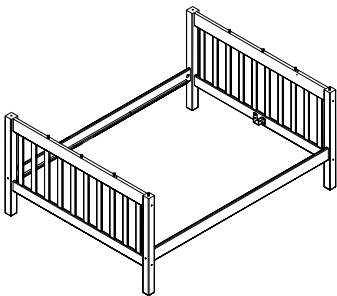

## HARDWARE REQUIRED

K  GLUE 01

L  Ø10 x 100mm 04

## TOOLS REQUIRED

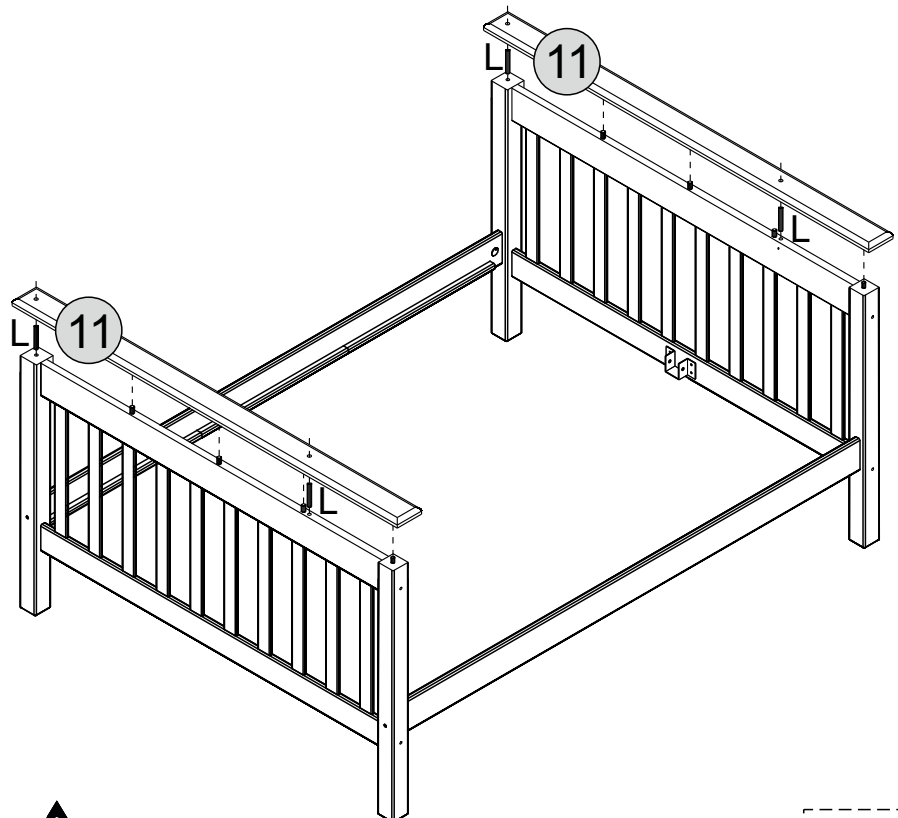

 **Glue must be added to the dowel holes on part 11.**

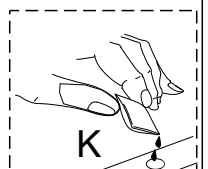

# STEP 15

## PARTS REQUIRED

14- CENTRE SUPPORT RAIL x1

26- CENTRE SUPPORT LEG x1

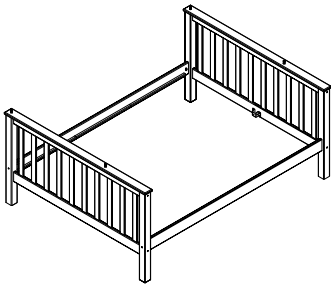

## HARDWARE REQUIRED

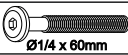
F  02  
Ø1/4 x 60mm

G  02  
1/4"

R  01  
Ø7 x 90mm

## TOOLS REQUIRED

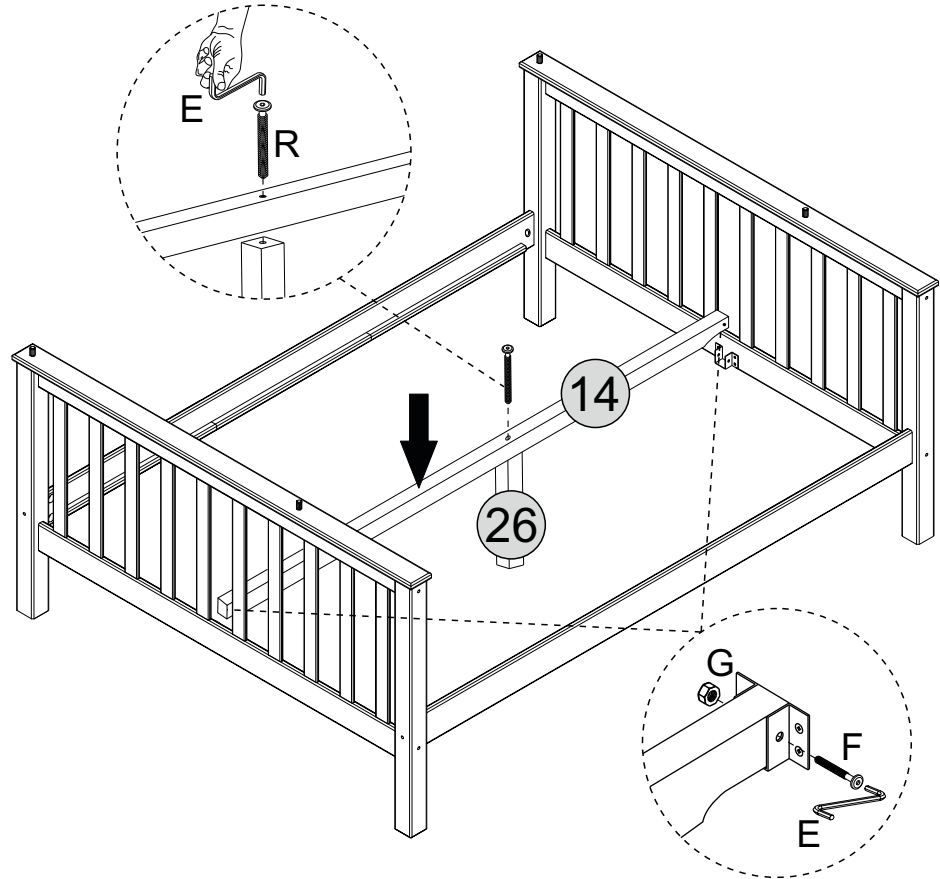
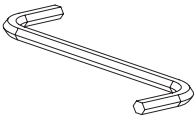

# STEP 16

## PARTS REQUIRED

15- 4" SLATS x14

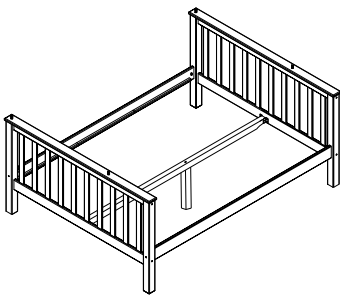

## HARDWARE REQUIRED

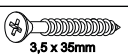
D  42  
3,5 x 35mm

M  02  
SPACER (WOODEN)

## TOOLS REQUIRED

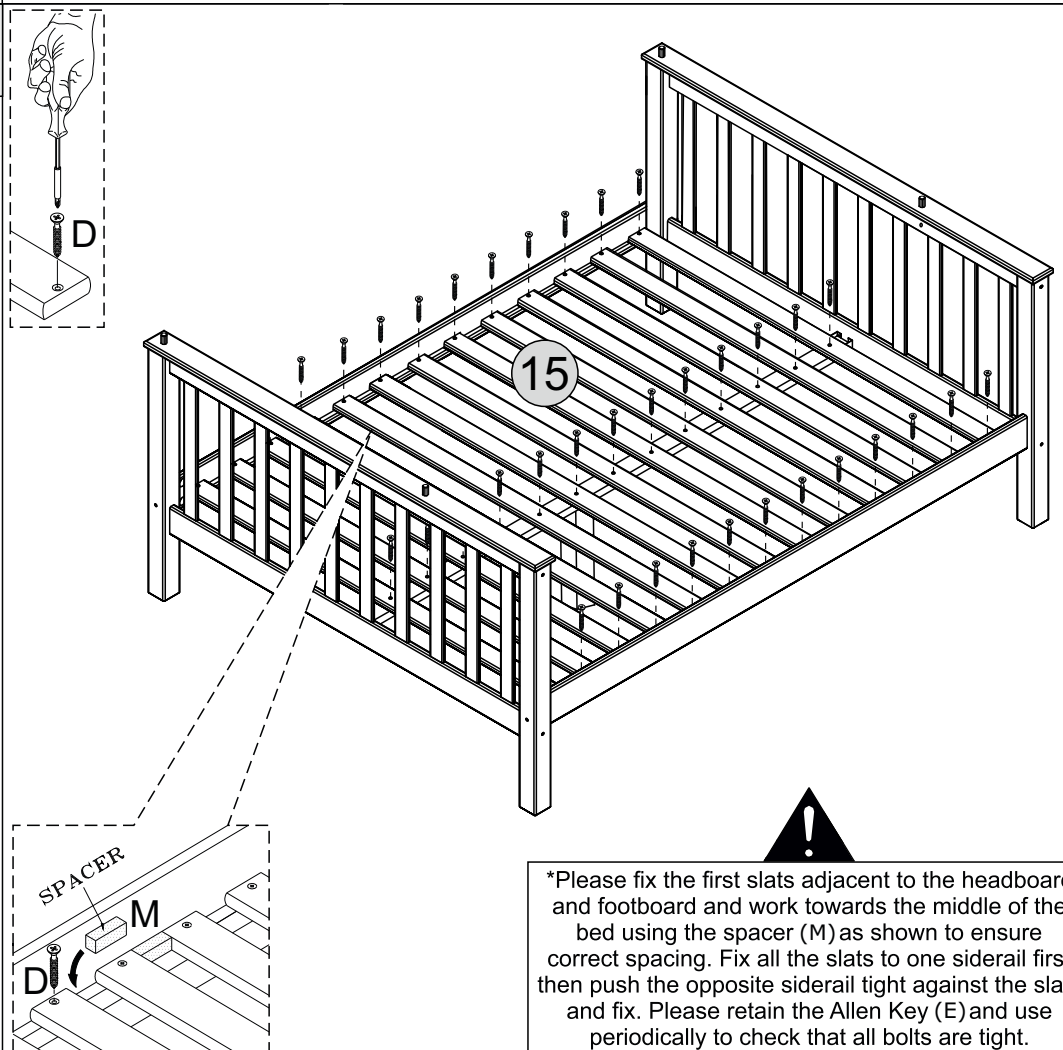
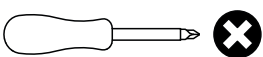

\*Please fix the first slats adjacent to the headboard and footboard and work towards the middle of the bed using the spacer (M) as shown to ensure correct spacing. Fix all the slats to one siderail first then push the opposite siderail tight against the slats and fix. Please retain the Allen Key (E) and use periodically to check that all bolts are tight.

# STEP 17

## PARTS REQUIRED

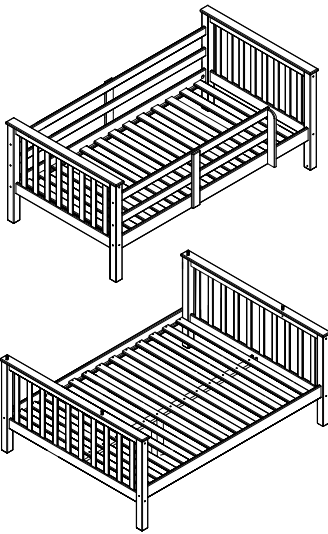

## HARDWARE REQUIRED

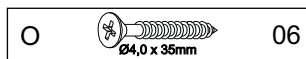

## TOOLS REQUIRED

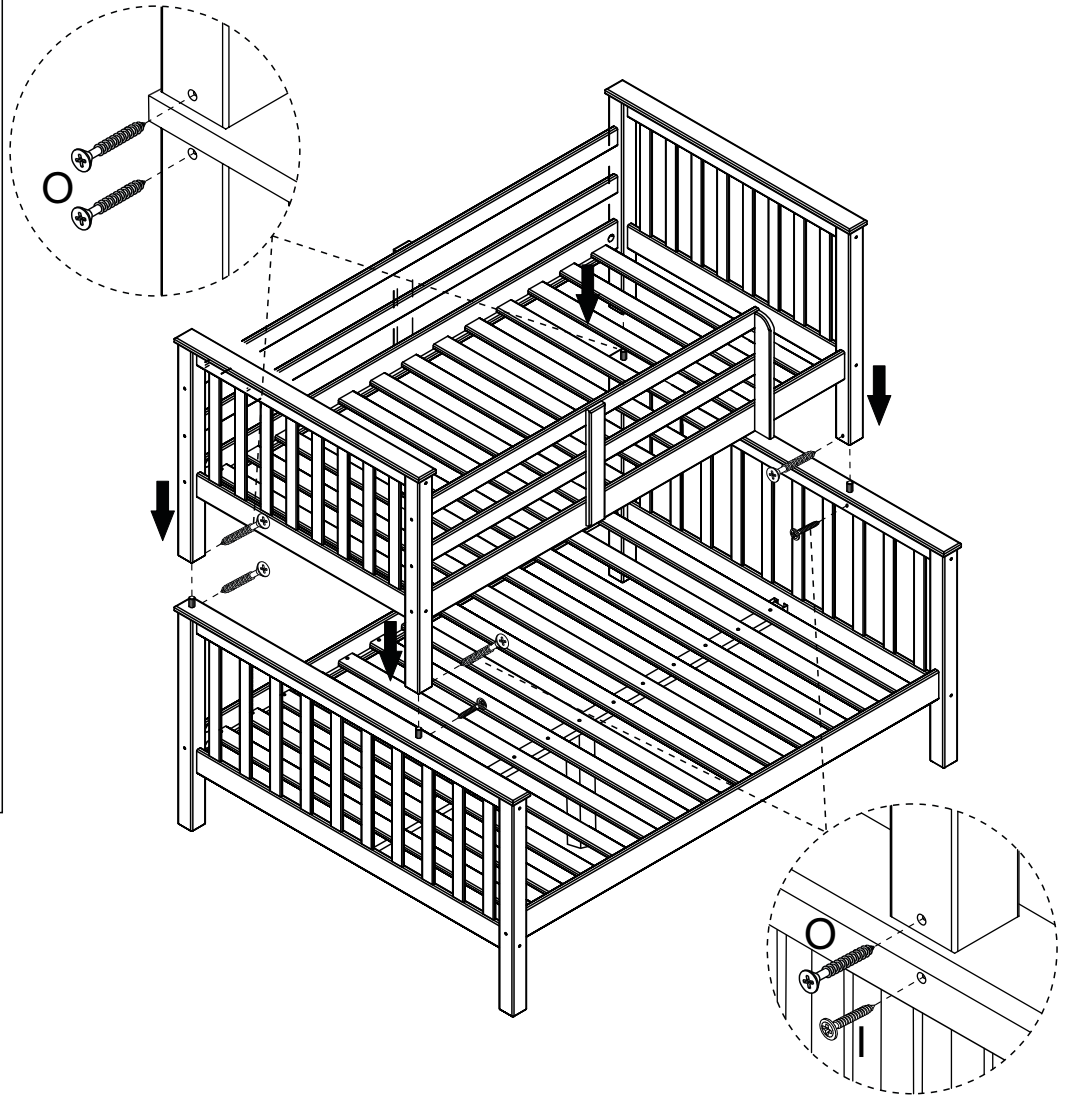
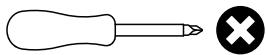





# STEP 18

## PARTS REQUIRED

17- LEFT LADDER SECTION	x1
18- RIGHT LADDER SECTION	x1
19- LADDER STEP	x3

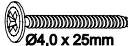
## HARDWARE REQUIRED

I	 04 Ø3,5 x 14mm
N	 02
T	 06 Ø4,0 x 25mm
K	 01 GLUE
S	 06 Ø10 x 50mm

## TOOLS REQUIRED

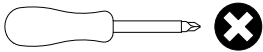

ADD GLUE TO THE DOWEL HOLES!

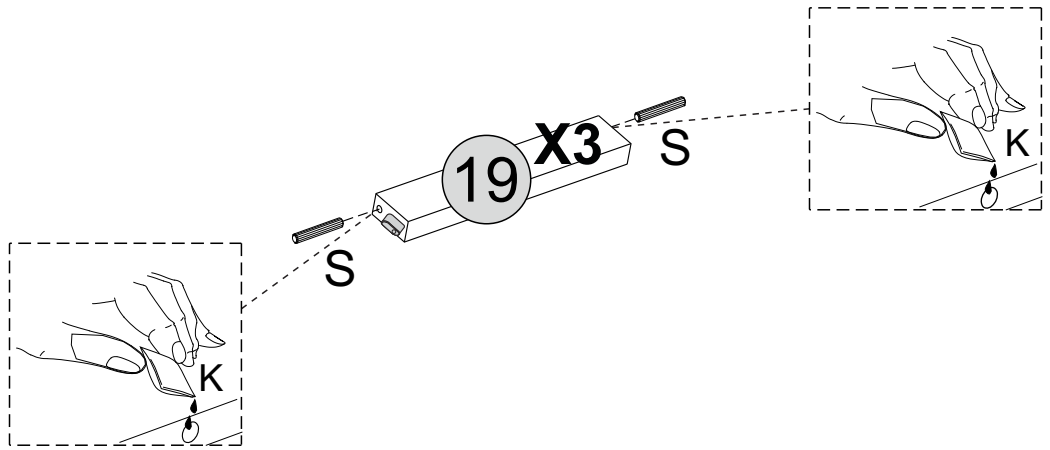

ADD GLUE TO BOTH DOWEL HOLES!

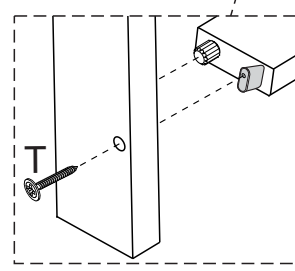
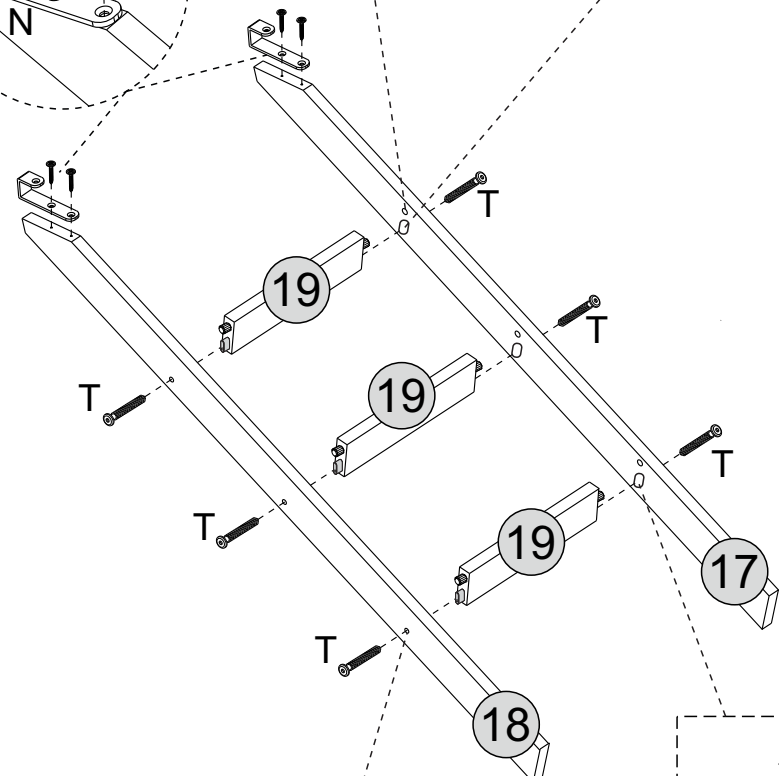
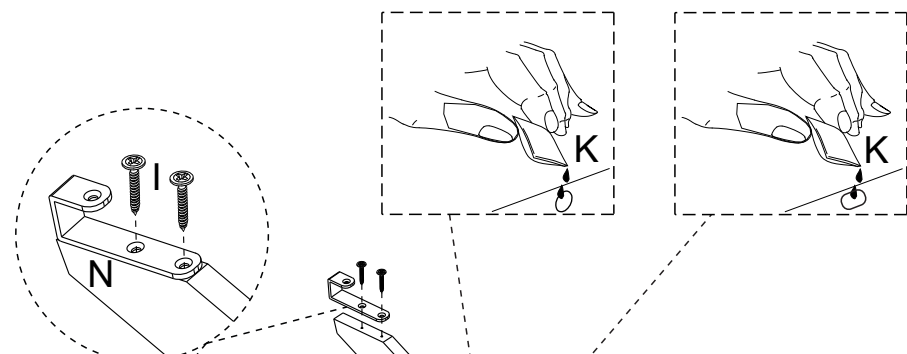

ADD GLUE AS ABOVE!

# STEP 19

**PARTS REQUIRED**

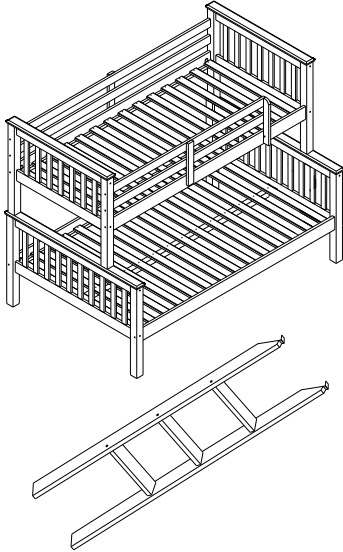

**HARDWARE REQUIRED**

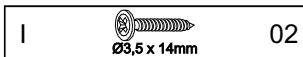

**TOOLS REQUIRED**

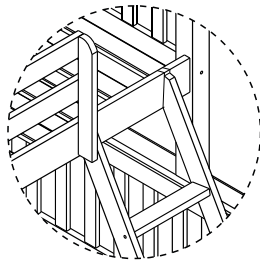
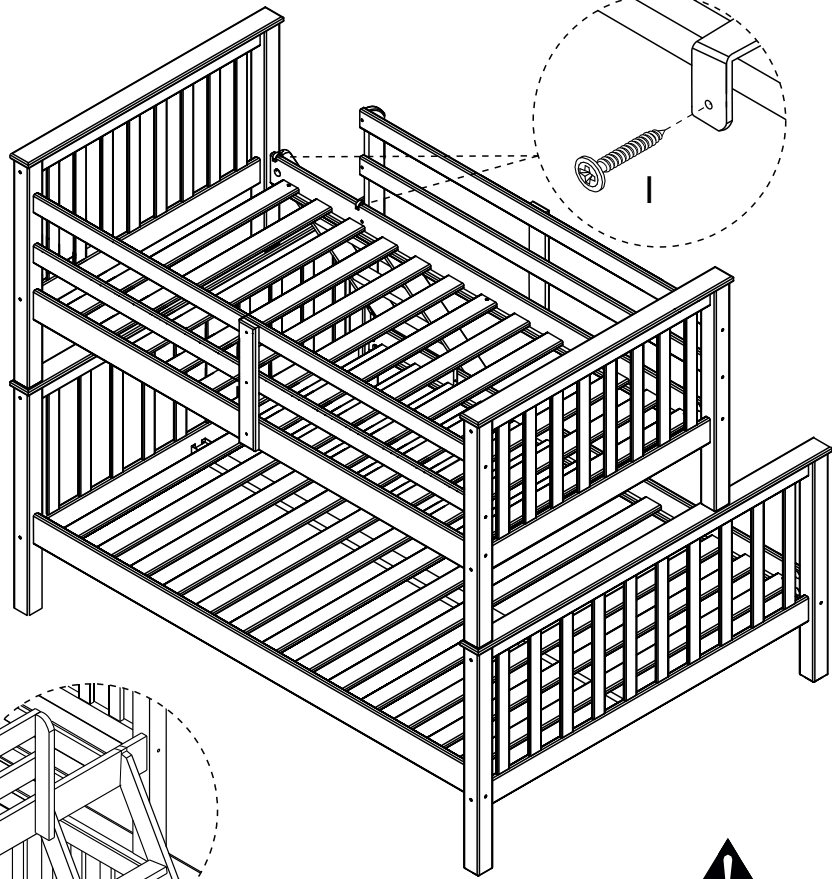
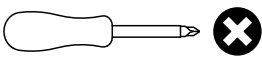

**!**  
When attaching the ladder to the siderail, please be sure to push the ladder up against part 13.

# STEP 20

**PARTS REQUIRED**

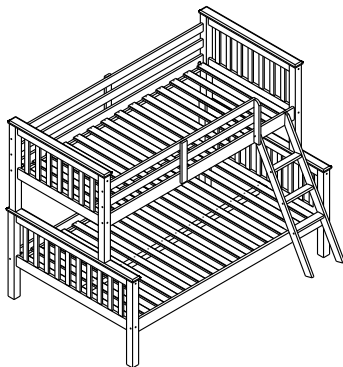

**HARDWARE REQUIRED**



**TOOLS REQUIRED**

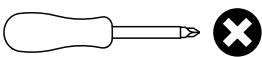

**100KG**  
TOP BUNK  
MAX WEIGHT

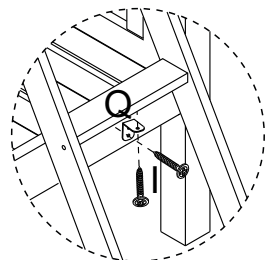
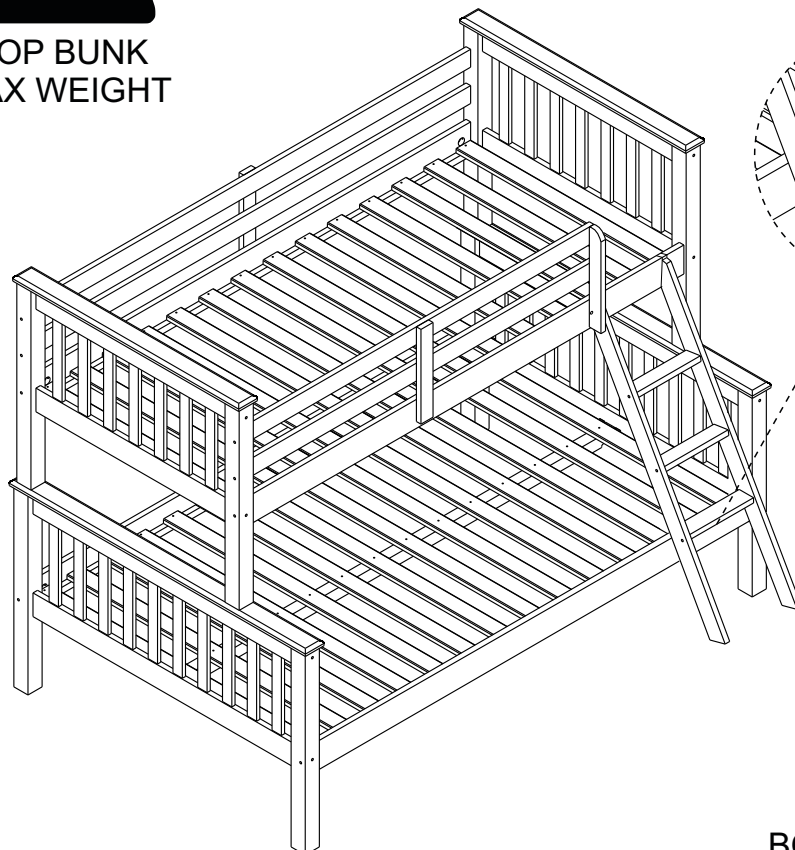

**180KG**  
BOTTOM BUNK  
MAX WEIGHT