

AMELIA 3' BED ASSEMBLY INSTRUCTIONS

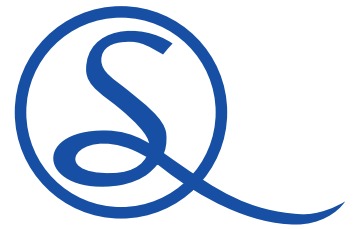

**MAX BED
WEIGHT**



FOR DOMESTIC USE ONLY IMPORTANT PLEASE READ BEFORE YOU CONTINUE FURTHER

THE PRODUCT YOU HAVE PURCHASED WILL GIVE YOU MANY YEARS OF SERVICE IF YOU FOLLOW THE GUIDELINES FOR ITS SAFE ASSEMBLY AND PERIODIC MAINTENANCE AND CLEANING.

ASSEMBLE ON A SOFT CLEAN SURFACE.

DO NOT USE ANY TOOLS OTHER THAN THOSE SHOWN.

ANY SPANNERS OR ALLEN KEYS REQUIRED ARE INCLUDED WITH THE FITTINGS KIT.

DO NOT FOR ANY REASON USE A POWER TOOL TO ASSEMBLE THIS PRODUCT . ITS USE WILL INVALIDATE ANY CLAIM YOU MAY HAVE AND COULD MAKE THIS PRODUCT UNSAFE.

DEPENDING ON THE AMOUNT OF USE THIS PRODUCT RECEIVES IT MAY BE NECESSARY TO TIGHTEN UP THE FIXINGS FROM TIME TO TIME. THIS IS COMPLETELY NORMAL FOR ANY FLAT PACK FURNITURE.

FOR CLEANING YOU MAY USE A DAMP CLOTH(NOT WET). DO NOT USE POLISH,DETERGENT OR CHEMICAL CLEANERS.

THIS PRODUCT MAY STAIN OR MARK IF ALLOWED TO COME INTO CONTACT WITH WET OR DAMP OBJECTS AS MATERIALS USED HAVE NOT BEEN SCOTCH GUARDED.

THE SURFACE OF THIS ITEM IS NOT HEAT RESISTANT, ALWAYS USE A PLACE MAT UNDER **HOT** OR COLD ITEMS. PREVENT MARKING

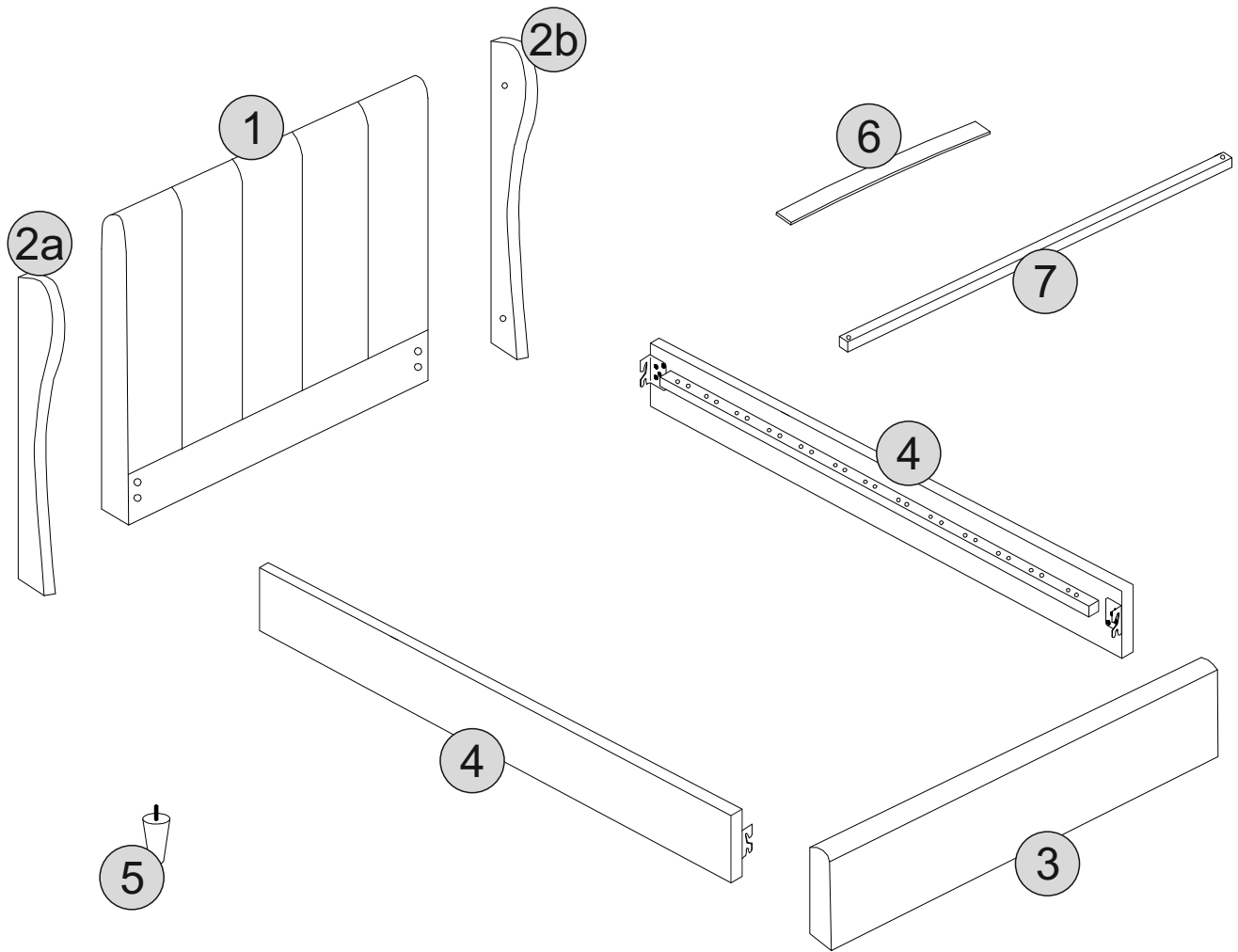







PART LIST

| Part Number | Part Code | Part Description | Quantity | Carton |
|-------------|----------------------|-------------------|----------|--------|
| 1 | S200-201-064-YF1-01 | Headboard | 1 | 1/2 |
| 2a | S200-201-064-YF1-02A | Left Wing | 1 | 1/2 |
| 2b | S200-201-064-YF1-02B | Right Wing | 1 | 1/2 |
| 3 | S200-201-064-YF1-03 | Footboard | 1 | 1/2 |
| 4 | S200-201-064-YF1-04 | Side Rail | 2 | 2/2 |
| 5 | S200-201-064-YF1-05 | Wooden Feet | 4 | 1/2 |
| 6 | S200-201-064-YF1-06 | Wooden Slat | 13 | 1/2 |
| 7 | S200-201-064-YF1-07 | Centre Cross Rail | 1 | 2/2 |

PLEASE CHECK THAT YOU HAVE ALL THE PARTS LISTED BEFORE YOU START ASSEMBLING, IF YOU DO FIND THAT SOMETHING IS MISSING, DO NOT CONTINUE ASSEMBLY. PLEASE CONTACT YOUR SUPPLIER IMMEDIATELY.

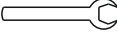
HARDWARE LIST

| No | Part Name | | Qty | Carton |
|----|------------------|--|-----|--------|
| A | 5/16 x 25mm Bolt |  | x8 | 2/2 |
| B | 5/16 x 45mm Bolt |  | x6 | 2/2 |
| C | M8 Washer |  | x8 | 2/2 |
| D | Allen Key |  | x1 | 2/2 |
| E | Spanner |  | x1 | 2/2 |
| F | Nut |  | x2 | 2/2 |
| G | Plastic Cap |  | x26 | 2/2 |

PLEASE CHECK THAT YOU HAVE ALL THE PARTS LISTED BEFORE YOU START ASSEMBLING, IF YOU DO FIND THAT SOMETHING IS MISSING, DO NOT CONTINUE ASSEMBLY. PLEASE CONTACT YOUR SUPPLIER IMMEDIATELY.

STEP 1

PARTS REQUIRED

| | |
|---------------|----|
| 1 - HEADBOARD | x1 |
|---------------|----|

| | |
|-----------------|----|
| 5 - WOODEN FEET | x2 |
|-----------------|----|

HARDWARE REQUIRED

TOOLS REQUIRED

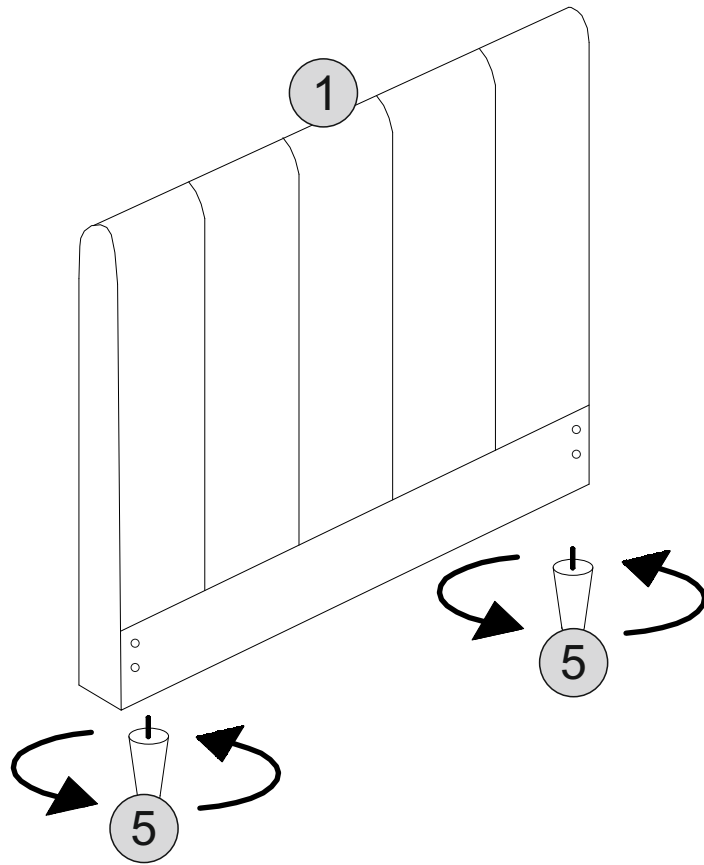

STEP 2

PARTS REQUIRED

| | |
|---------------|----|
| 3 - FOOTBOARD | x1 |
|---------------|----|

| | |
|-----------------|----|
| 5 - WOODEN FEET | x2 |
|-----------------|----|

HARDWARE REQUIRED

TOOLS REQUIRED

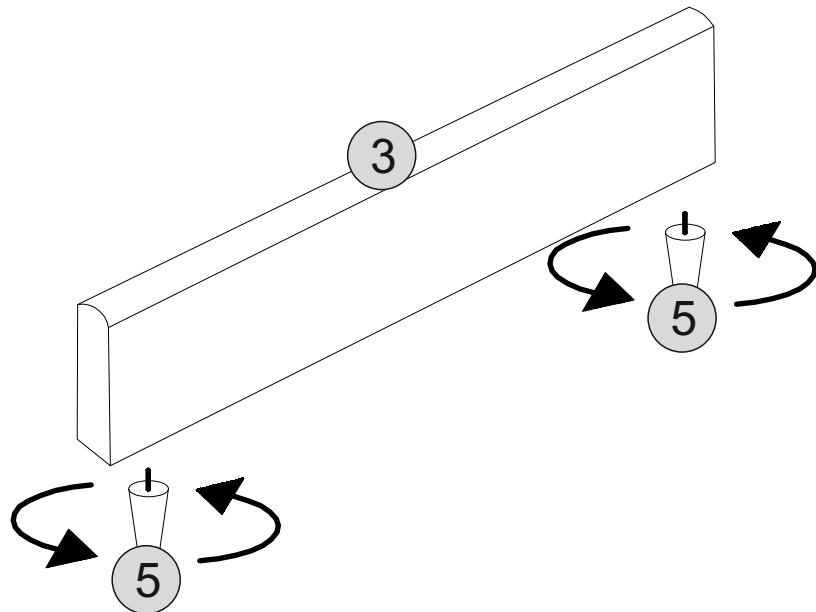

STEP 3

PARTS REQUIRED

1 - HEADBOARD x1

3 - FOOTBOARD x1

4 - SIDE RAIL x2

HARDWARE REQUIRED

A  08

TOOLS REQUIRED

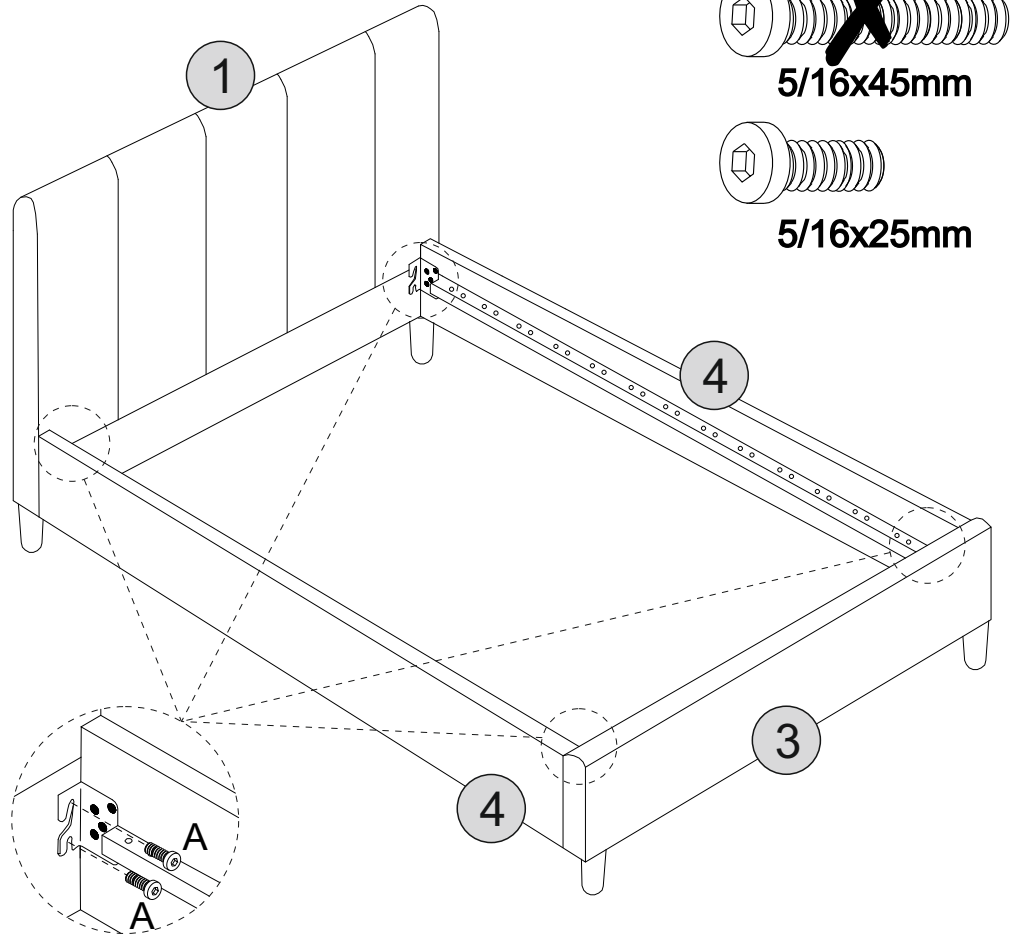

STEP 4

PARTS REQUIRED

7 - CENTRE CROSS RAIL x1

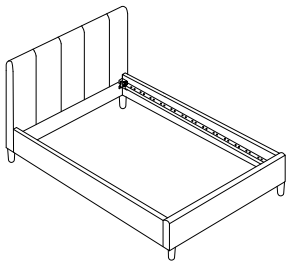

HARDWARE REQUIRED

B  02

C  04

F  02

TOOLS REQUIRED

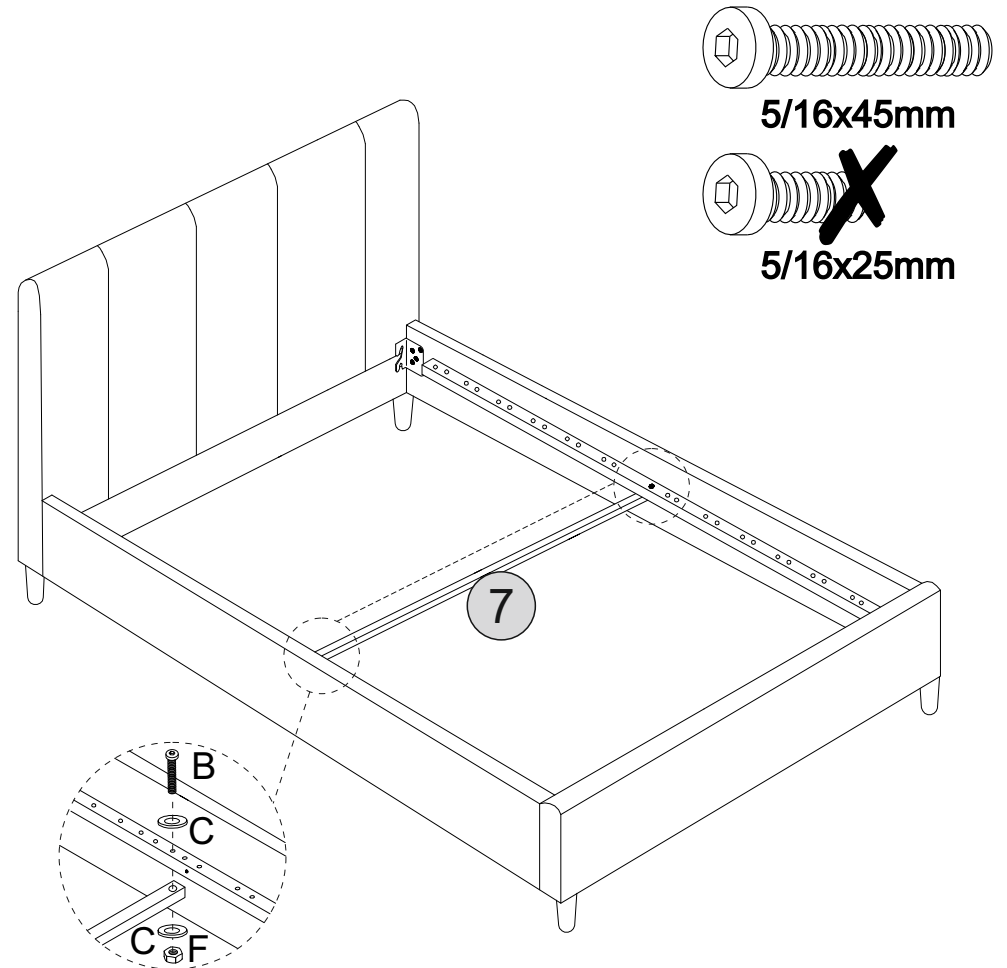
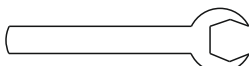

STEP 5

PARTS REQUIRED

6 - WOODEN SLAT x13

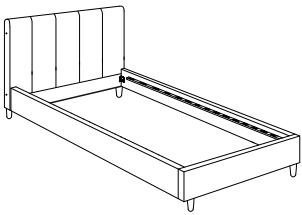

HARDWARE REQUIRED

G  26

TOOLS REQUIRED

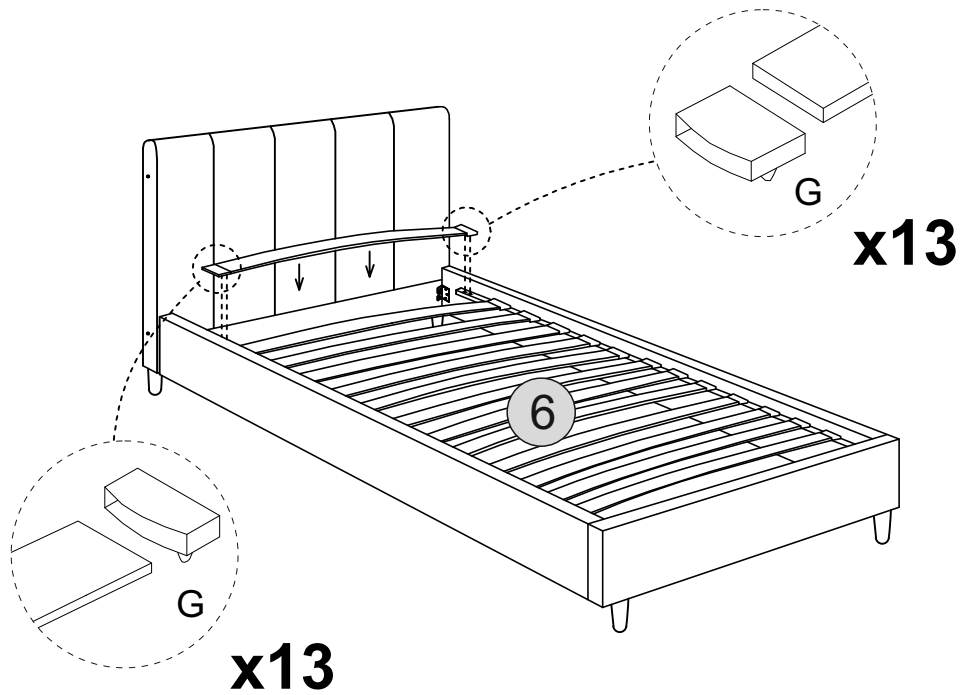

STEP 6

PARTS REQUIRED

2a - LEFT WING x1

2b - RIGHT WING x1

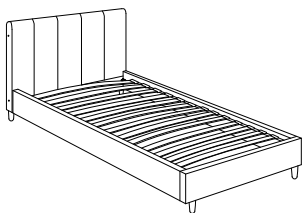

HARDWARE REQUIRED

B  04

C  04

TOOLS REQUIRED

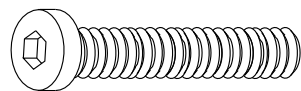

5/16x45mm

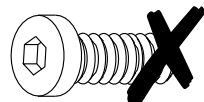

5/16x25mm

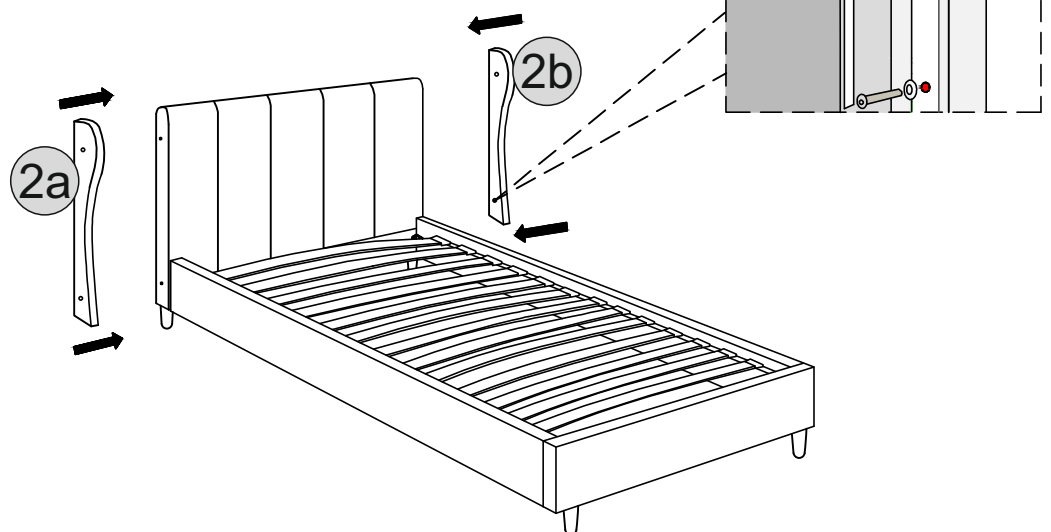

STEP 7

