

# OSLO 2 DOOR WARDROBE ASSEMBLY INSTRUCTIONS

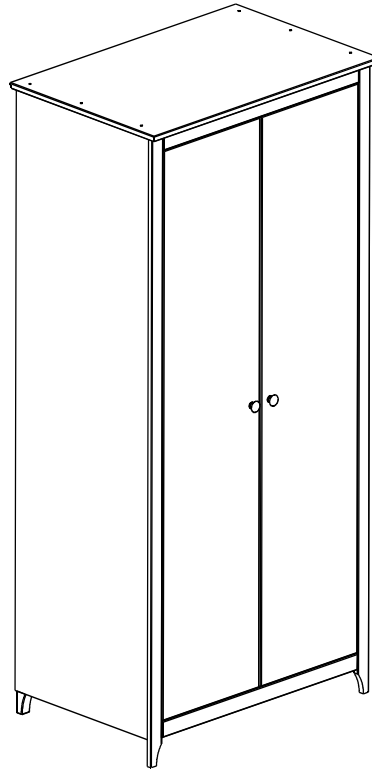

**IMPORTANT  
FOR DOMESTIC USE ONLY**

**PLEASE READ BEFORE YOU CONTINUE FURTHER**

## CARE AND MAINTENANCE

After unpacking this product please keep the original packaging in case it needs to be returned for any reason.

- Please ensure all fittings and parts are present before commencing with assembly.
- Never drag or push products as this could cause damage to the joints making it inferior.
- We strongly recommend that you keep children away from your work area.
- We recommend that you lay a blanket or sheet on the floor to avoid damage to both your floor and the product.
- Assemble this product as close to its final position as possible.
- Do not place this product next to a radiator or in direct sunlight.
- Do not drag or push items across your high gloss furniture as this may cause the surface to scratch
- Wood is a natural product and may expand if subjected to damp and may shrink or crack if subjected to heat. Therefore it is recommended that room temperature is maintained, with no sudden temperature fluctuations.
- Make sure any spillage is wiped off immediately.
- Do not place hot or chilled items directly on to the surface, use a place mat or marking will occur.
- For general cleaning use a soft cotton or micro fibre cloth, and do not use detergents of any kind.
- From time to time it may be necessary to tighten fittings, regular inspections should be carried out.
- Do not place on a wet or damp floor as staining may occur to your floor.

## TOOLS REQUIRED

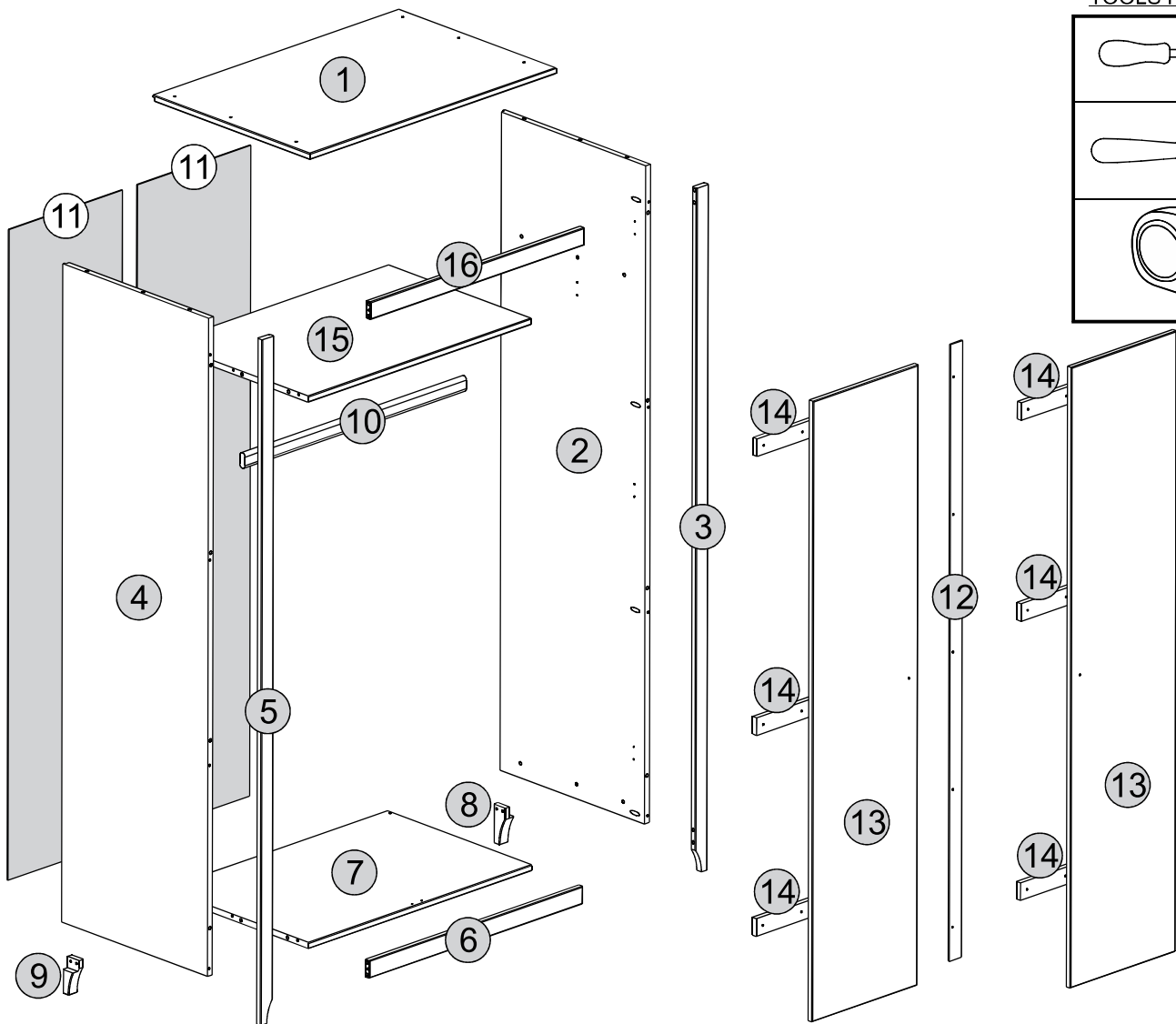
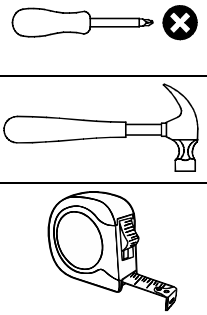











**PARTS LIST*****Please Note:***

The below parts have all been stamped with the part number to help identify them during assembly.

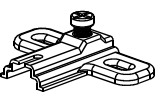
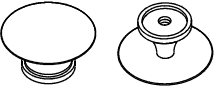
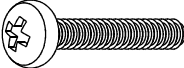
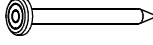
<b>Part Number</b>	<b>Part Code</b>	<b>Part Description</b>	<b>Quantity</b>	<b>Carton</b>
1	S100-101-196-MY1-01	Top Panel	1	2/2
2	S100-101-196-MY1-02	Right Side Panel	1	1/2
3	S100-101-196-MY1-03	Right Front Upright	1	1/2
4	S100-101-196-MY1-04	Left Side Panel	1	1/2
5	S100-101-196-MY1-05	Left Front Upright	1	1/2
6	S100-101-196-MY1-06	Lower Front Crossbeam	1	1/2
7	S100-101-196-MY1-07	Base	1	2/2
8	S100-101-196-MY1-08	Right Back Foot	1	1/2
9	S100-101-196-MY1-09	Left Back Foot	1	1/2
10	S100-101-196-MY1-10	Hanger	1	2/2
11	S100-101-196-MY1-11	Back Panel	2	1/2
12	S100-101-196-MY1-12	Door Strip	1	1/2
13	S100-101-196-MY1-13	Door	2	1/2
14	S100-101-196-MY1-14	Door Crossbeam	6	1/2
15	S100-101-196-MY1-15	Fixed Shelf	1	2/2
16	S100-101-196-MY1-16	Upper Front Crossbeam	1	1/2

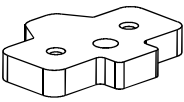
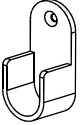
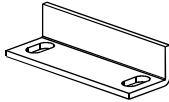
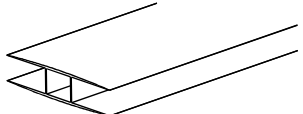

**FITTINGS LIST**

<p><b>A</b></p>  <p>Dowel Ø8,0 x 30mm (34x) +2</p>	<p><b>B</b></p>  <p>Screw Ø3,5 x 30mm (25x) +1</p>	<p><b>C</b></p>  <p>Flan Head Screw Ø4,0 x 35mm (6x) +1</p>	<p><b>D</b></p>  <p>Screw Ø4,0 x 40mm (6x) +1</p>
<p><b>E</b></p>  <p>Screw Ø4,0 x 25mm (30x) +2</p>	<p><b>F</b></p>  <p>Screw Ø3,5 x 14mm (31x) +2</p>	<p><b>G</b></p>  <p>Hinge (Door) (6x) +2</p>	<p><b>H</b></p>  <p>Hinge (Side Panel) (6x) +1</p>
<p><b>I</b></p>  <p>Metal Knob (2x) +1</p>	<p><b>J</b></p>  <p>Screw ØM4 x 22mm (2x) +1</p>	<p><b>K</b></p>  <p>Nail 8 x 8 (40x) +2</p>	<p><b>L</b></p>  <p>Corner (4x) +1</p>
<p><b>M</b></p>  <p>Hinge Spacer (6x) +1</p>	<p><b>N</b></p>  <p>Hanging Rail Support (2x) +1</p>	<p><b>O</b></p>  <p>Door Stop (1x) +1</p>	<p><b>P</b></p>  <p>Back Panel Strip 1633mm (1x) +1</p>
<p><b>Q</b></p>  <p>Strap (1x) +1</p>	<p><b>R</b></p>  <p>Washer (2x) +1</p>	<p><b>S</b></p>  <p>Glue (1x) +1</p>	

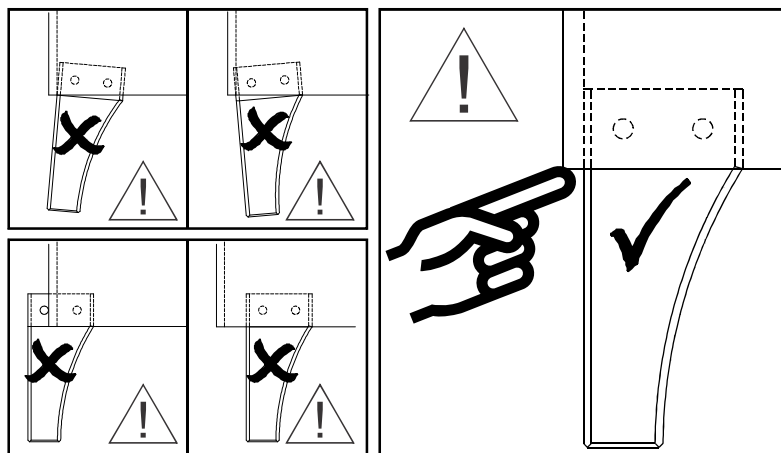

**PLEASE USE THE ABOVE EXAMPLE TO ASSEMBLE THE FEET ON STEP 2.**

# STEP 1

## PARTS REQUIRED

2 - RIGHT SIDE PANEL x1

4 - LEFT SIDE PANEL x1

## HARDWARE REQUIRED

A  14  
Ø8.0 x 30mm

S  01  
Glue

## TOOLS REQUIRED

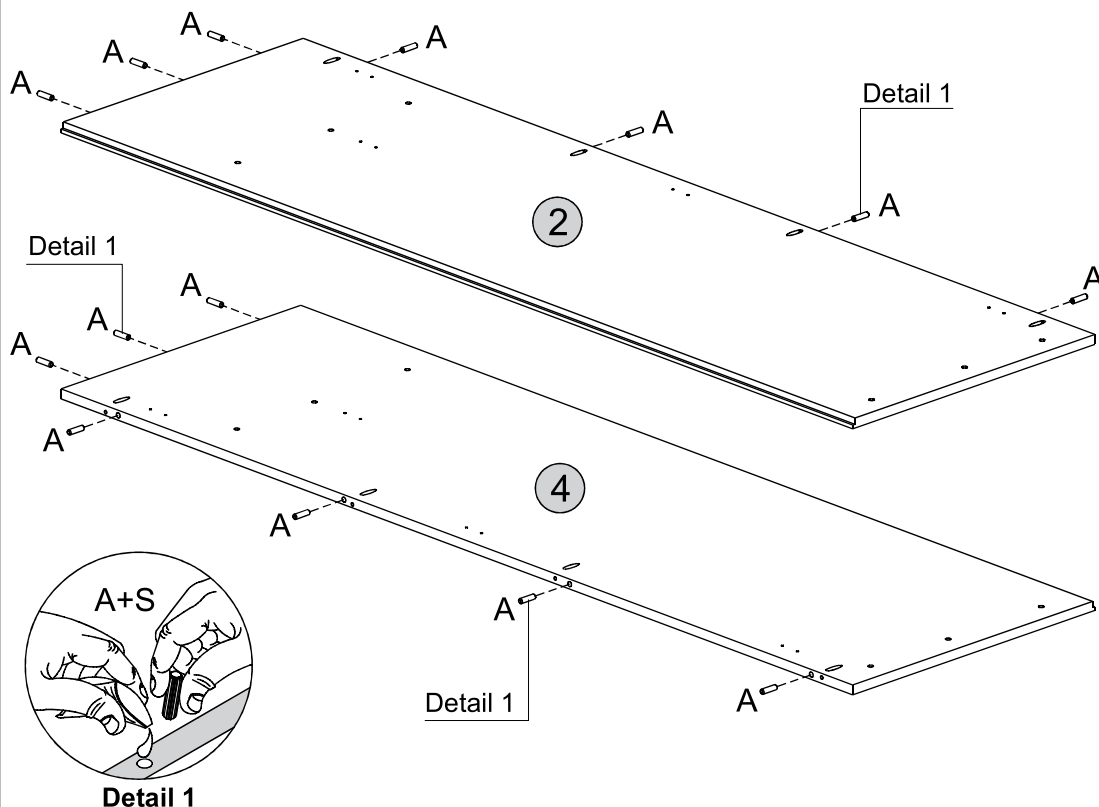
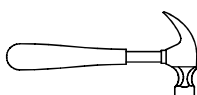

# STEP 2

## PARTS REQUIRED

2 - RIGHT SIDE PANEL x1

4 - LEFT SIDE PANEL x1

8 - RIGHT BACK FOOT x1

4 - LEFT BACK FOOT x1

## HARDWARE REQUIRED

C  04  
Ø4.0 x 35mm

## TOOLS REQUIRED

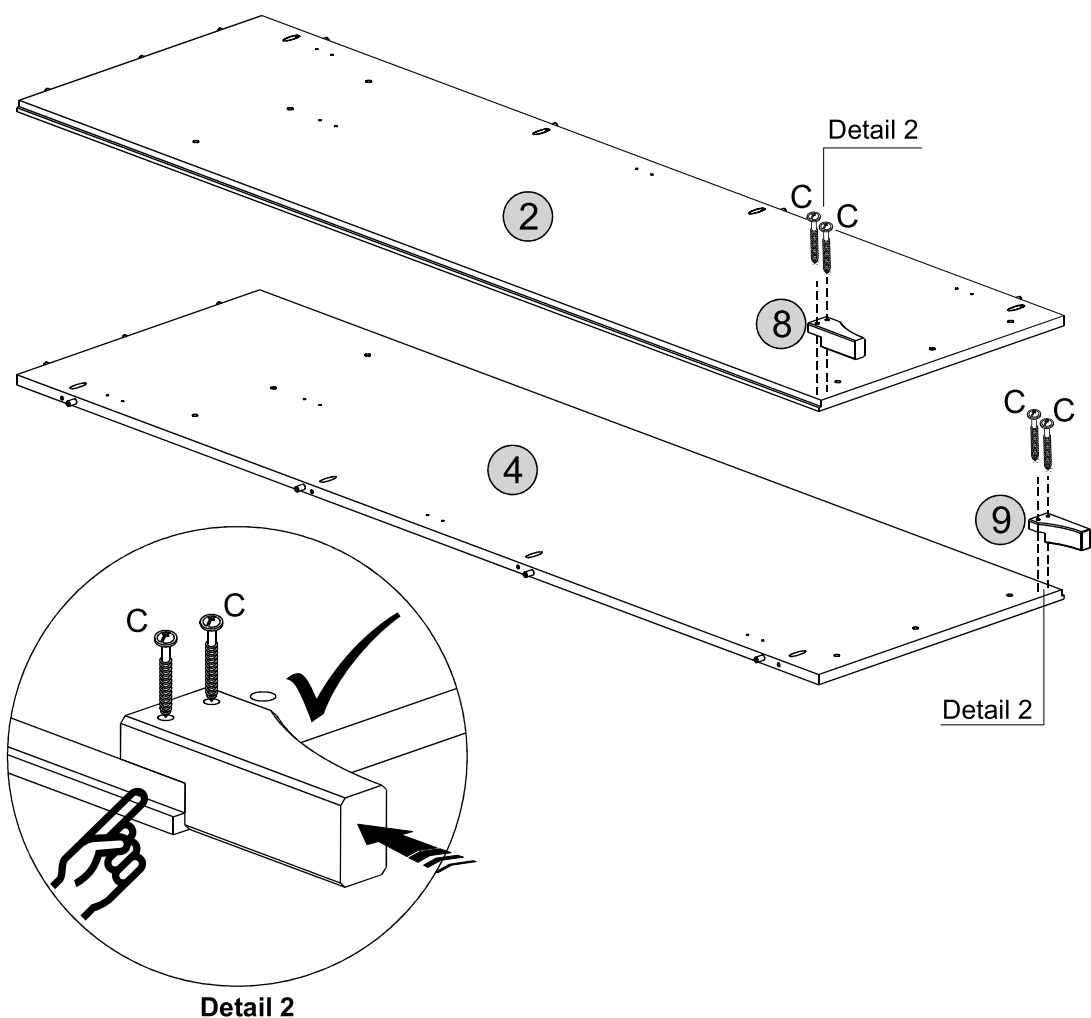
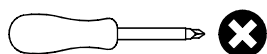

# STEP 3



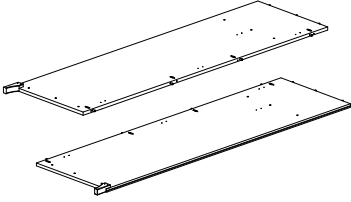

## PARTS REQUIRED

3 - RIGHT FRONT UPRIGHT x1

5 - LEFT FRONT UPRIGHT x1

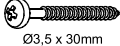

## HARDWARE REQUIRED

- B  08  
Ø3.5 x 30mm
- F  04  
Ø3.5 x 14mm
- N  02  
Hanger Support
- S  01  
Glue

## TOOLS REQUIRED

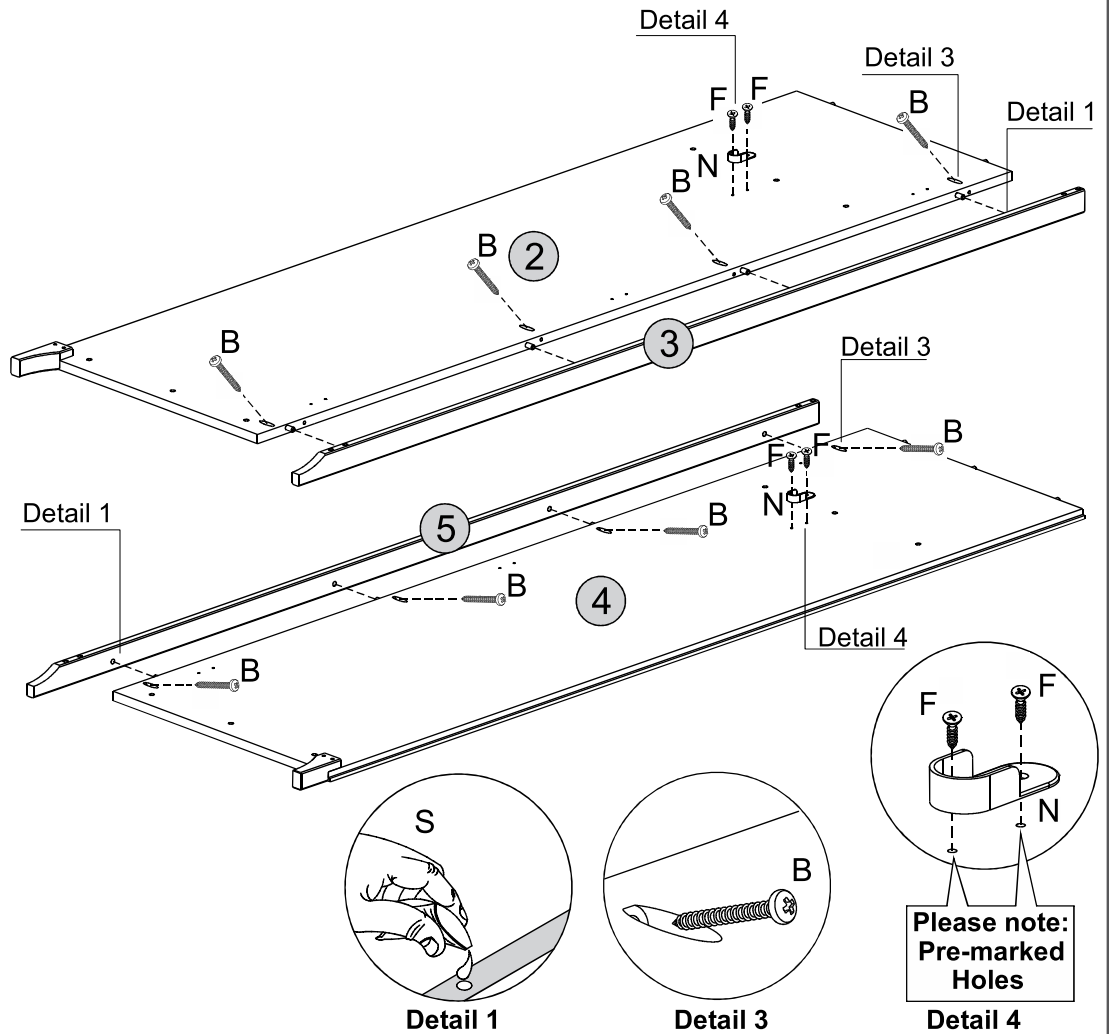
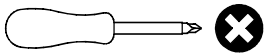



Please note:  
Pre-marked  
Holes

# STEP 4

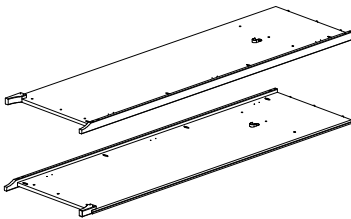
## PARTS REQUIRED



## HARDWARE REQUIRED

- E  12  
Ø4.0 x 25mm
- H  06  
Hinge (Side Panel) (6x)
- M  06  
Hinge Spacer

## TOOLS REQUIRED

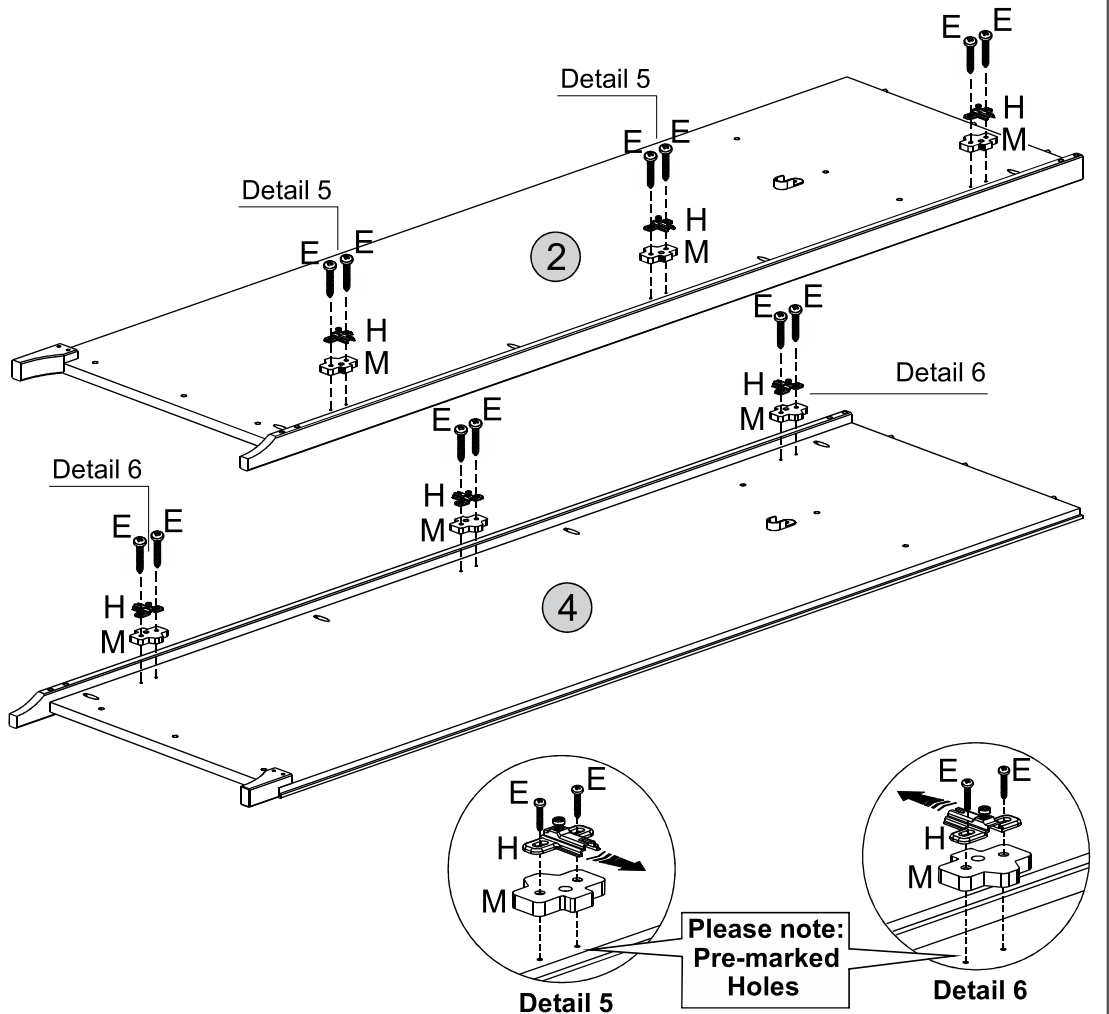
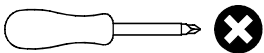

Please note:  
Pre-marked  
Holes

# STEP 5

## PARTS REQUIRED

6 - LOWER FRONT CROSSBEAM x1

16 - UPPER FRONT CROSSBEAM x1

## HARDWARE REQUIRED

A  08  
Ø8.0 x 30mm

F  02  
Ø3.5 x 14mm

L  02  
Corner

S  01  
Glue

## TOOLS REQUIRED

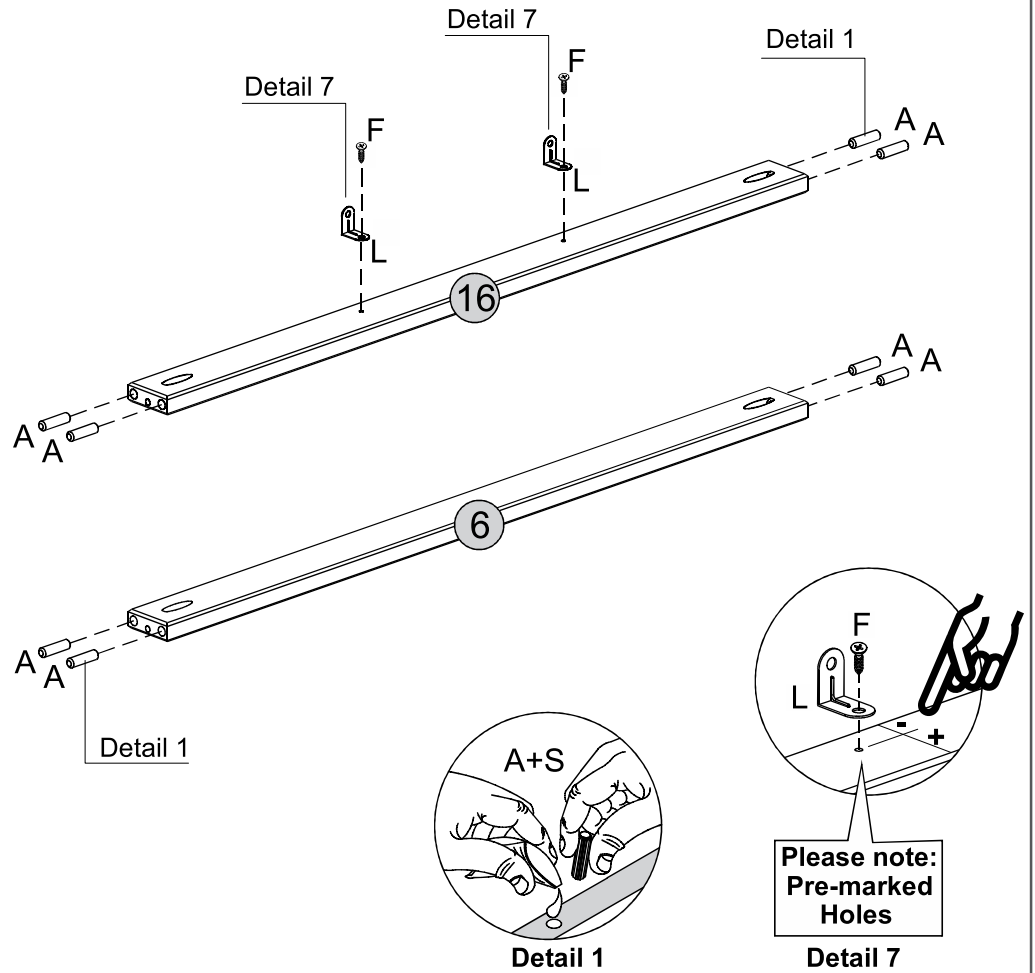
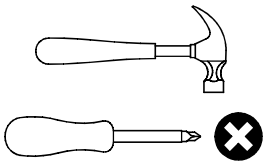

# STEP 6

## PARTS REQUIRED

7 - BASE x1

15 - FIXED SHELF x1

## HARDWARE REQUIRED

A  12  
Ø8.0 x 30mm

F  02  
Ø3.5 x 14mm

L  02  
Corner

S  01  
Glue

## TOOLS REQUIRED

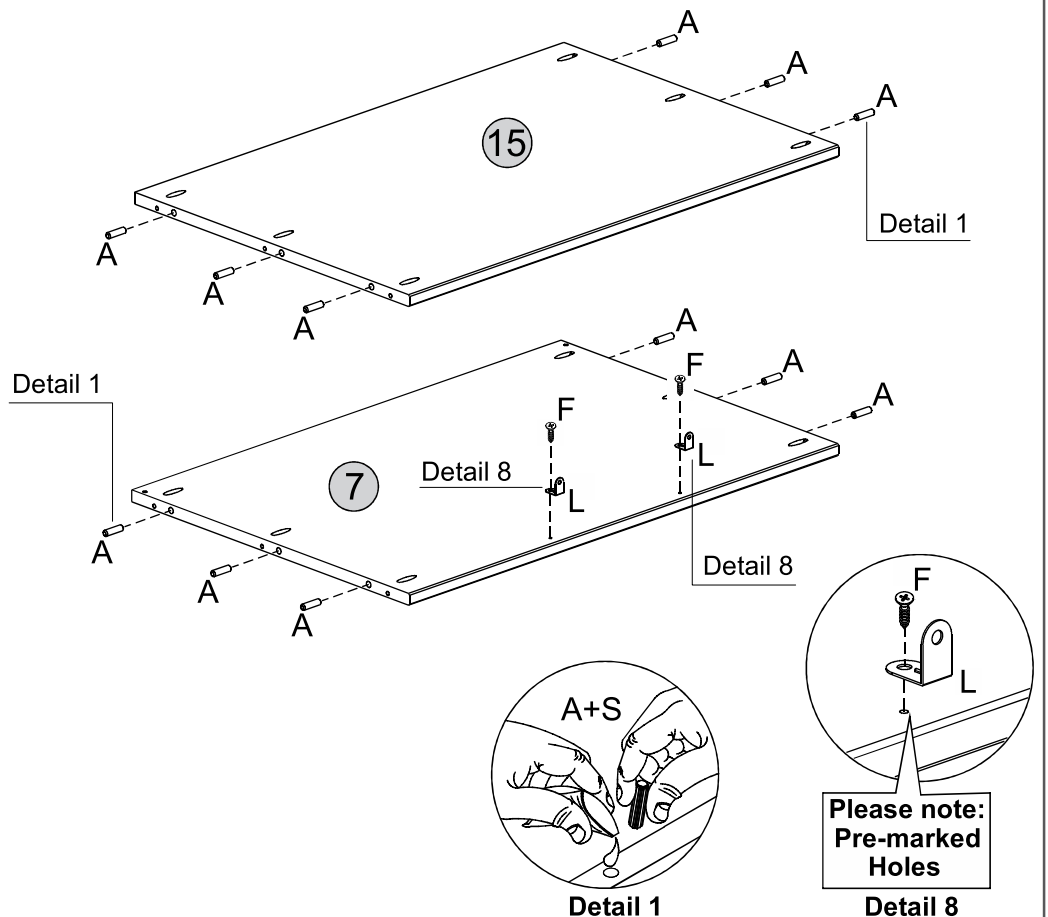
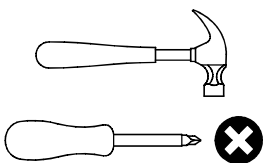

# STEP 7

## PARTS REQUIRED

6 - LOWER FRONT CROSSBEAM x1

16 - UPPER FRONT CROSSBEAM x1

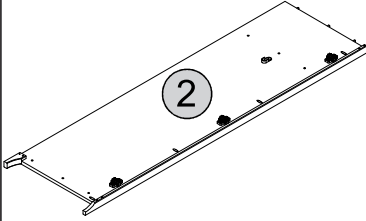

## HARDWARE REQUIRED

B  02  
Ø3.5 x 30mm

S  01  
Glue

## TOOLS REQUIRED

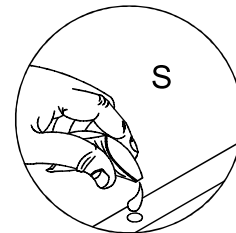
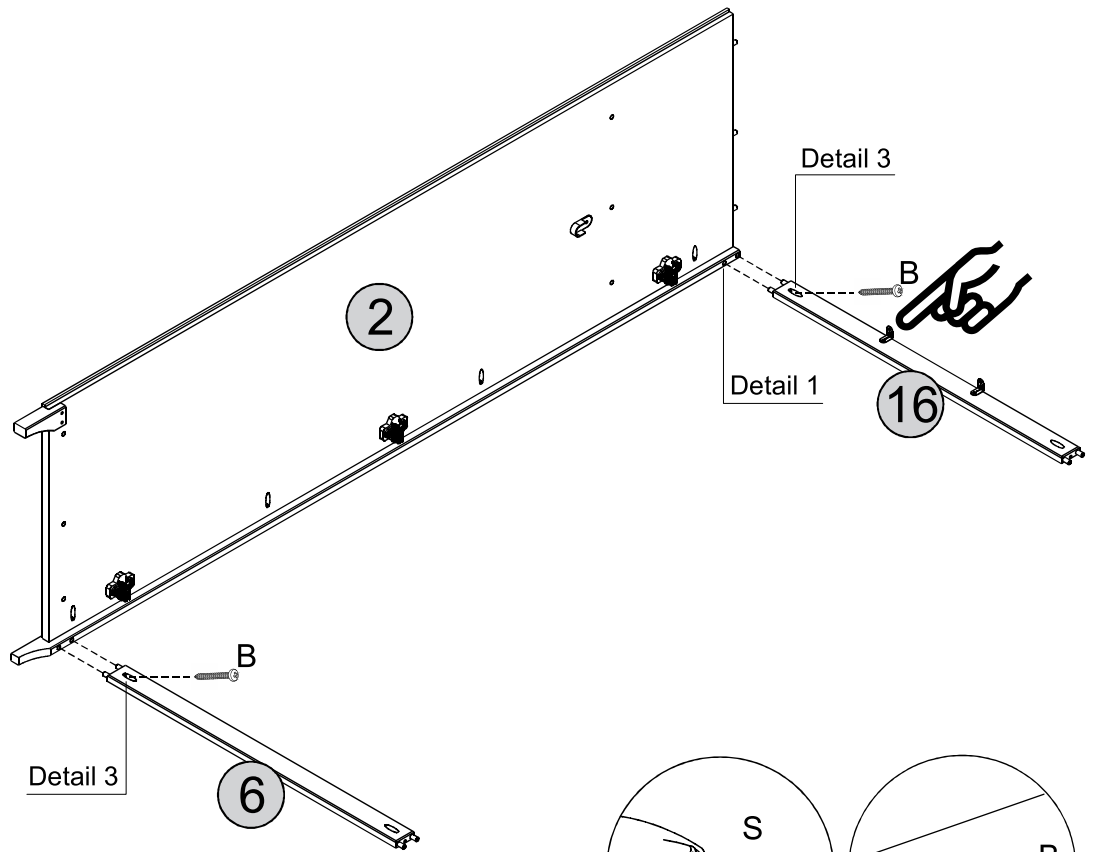
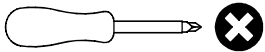

Detail 1

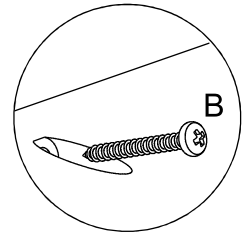

Detail 3

# STEP 8

## PARTS REQUIRED

7 - BASE x1

15 - FIXED SHELF x1

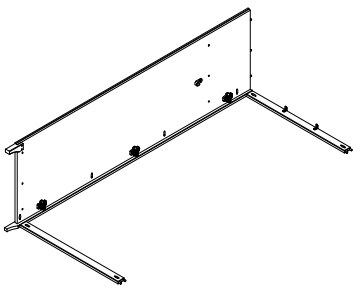

## HARDWARE REQUIRED

B  06  
Ø3.5 x 30mm

S  01  
Glue

## TOOLS REQUIRED

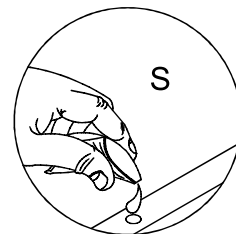
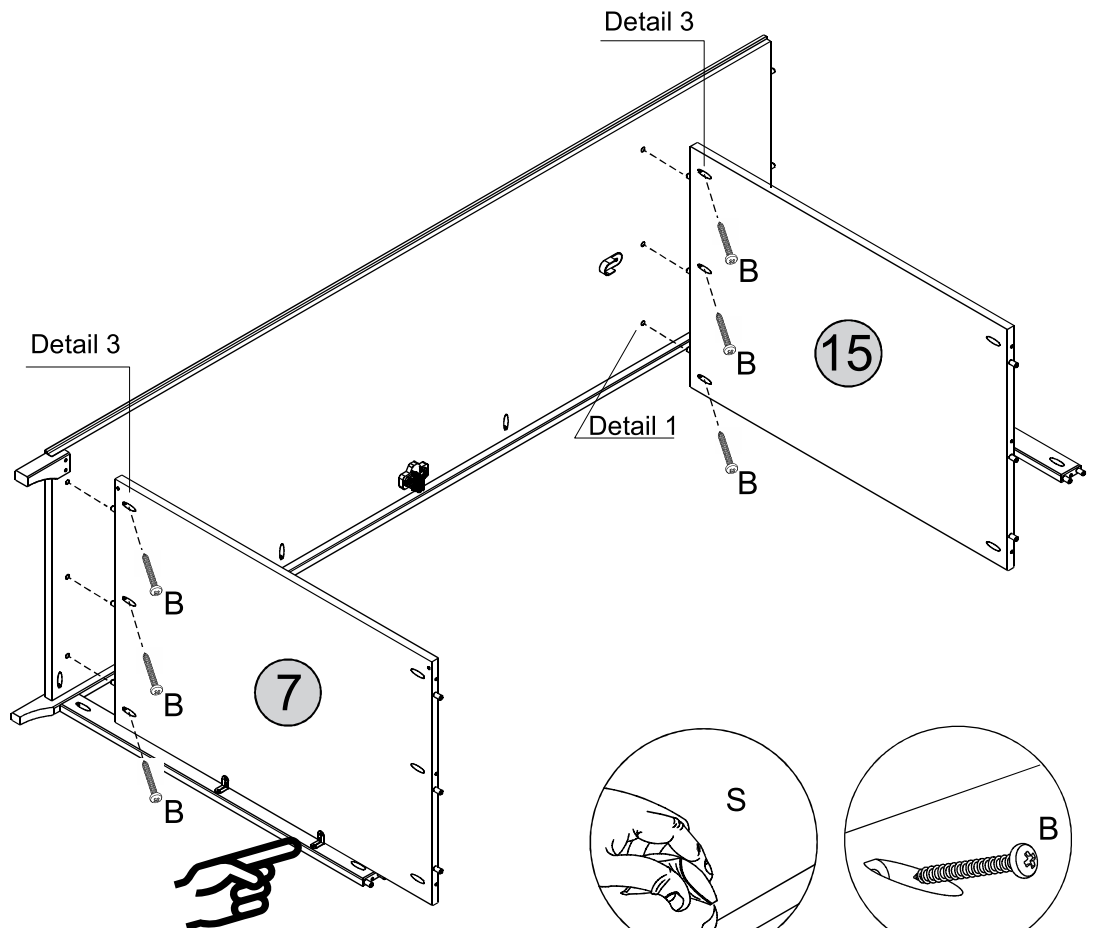
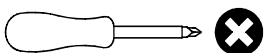

Detail 1

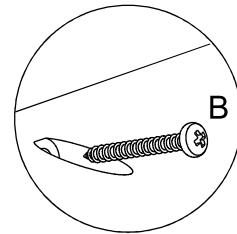

Detail 3

# STEP 9

## PARTS REQUIRED

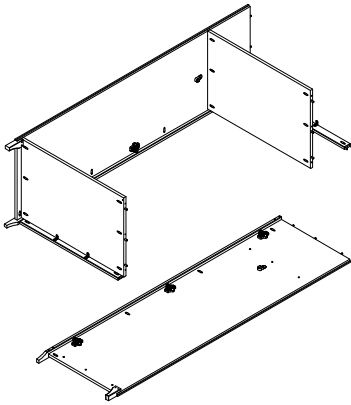

## HARDWARE REQUIRED

B		08
S		01

## TOOLS REQUIRED

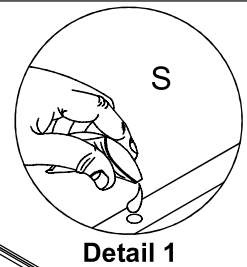
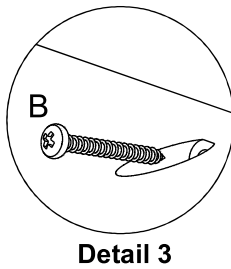
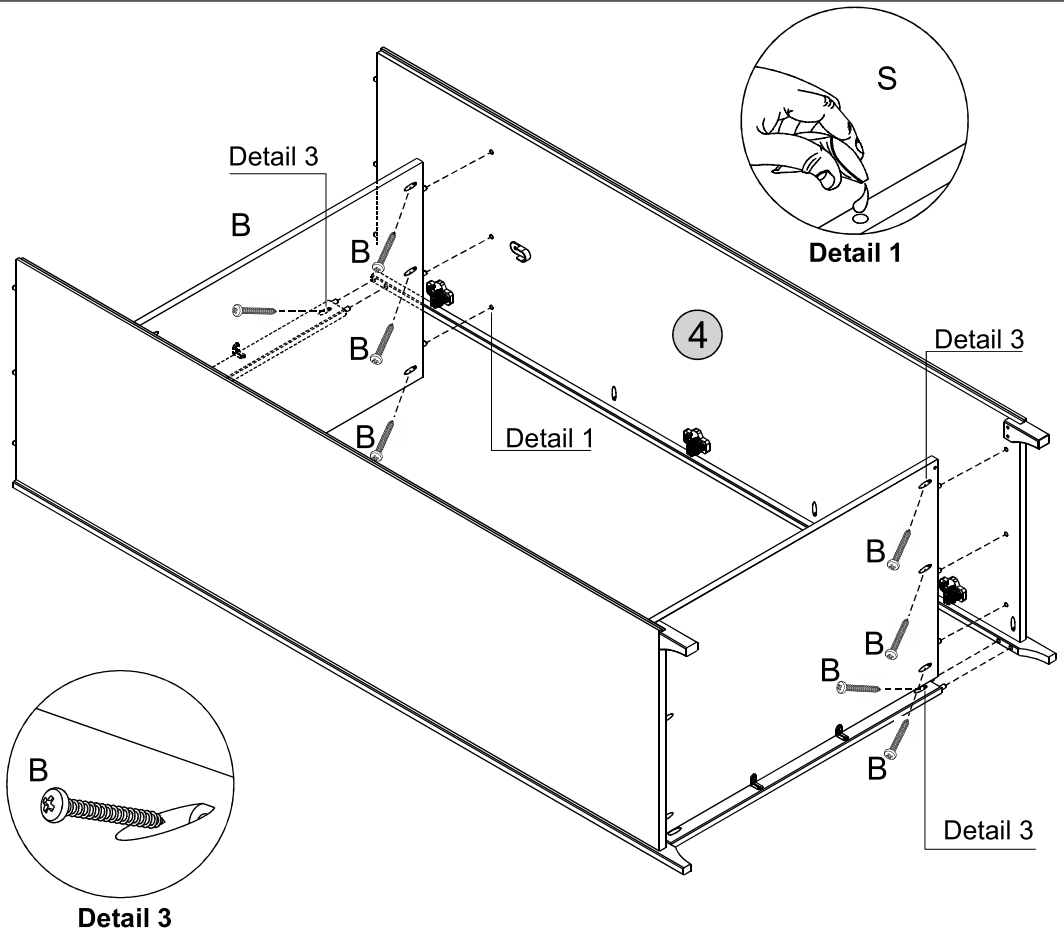
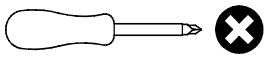

# STEP 10

## PARTS REQUIRED

1 - TOP PANEL	x1
---------------	----

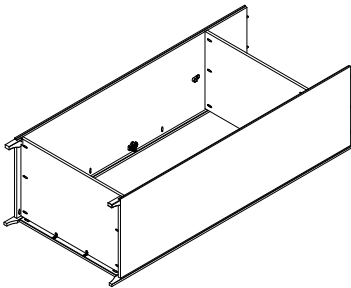

## HARDWARE REQUIRED

C		02
D		06
F		04
S		01

## TOOLS REQUIRED

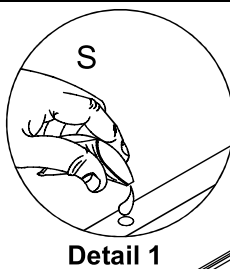
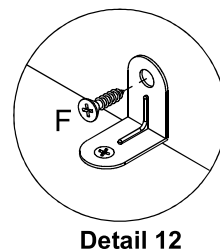
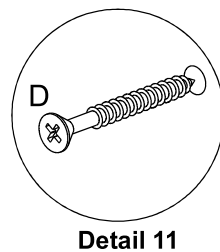
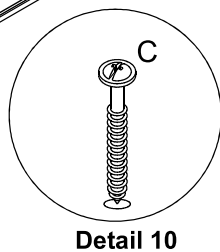
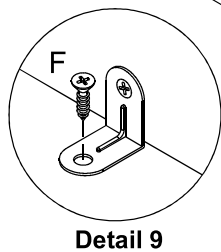
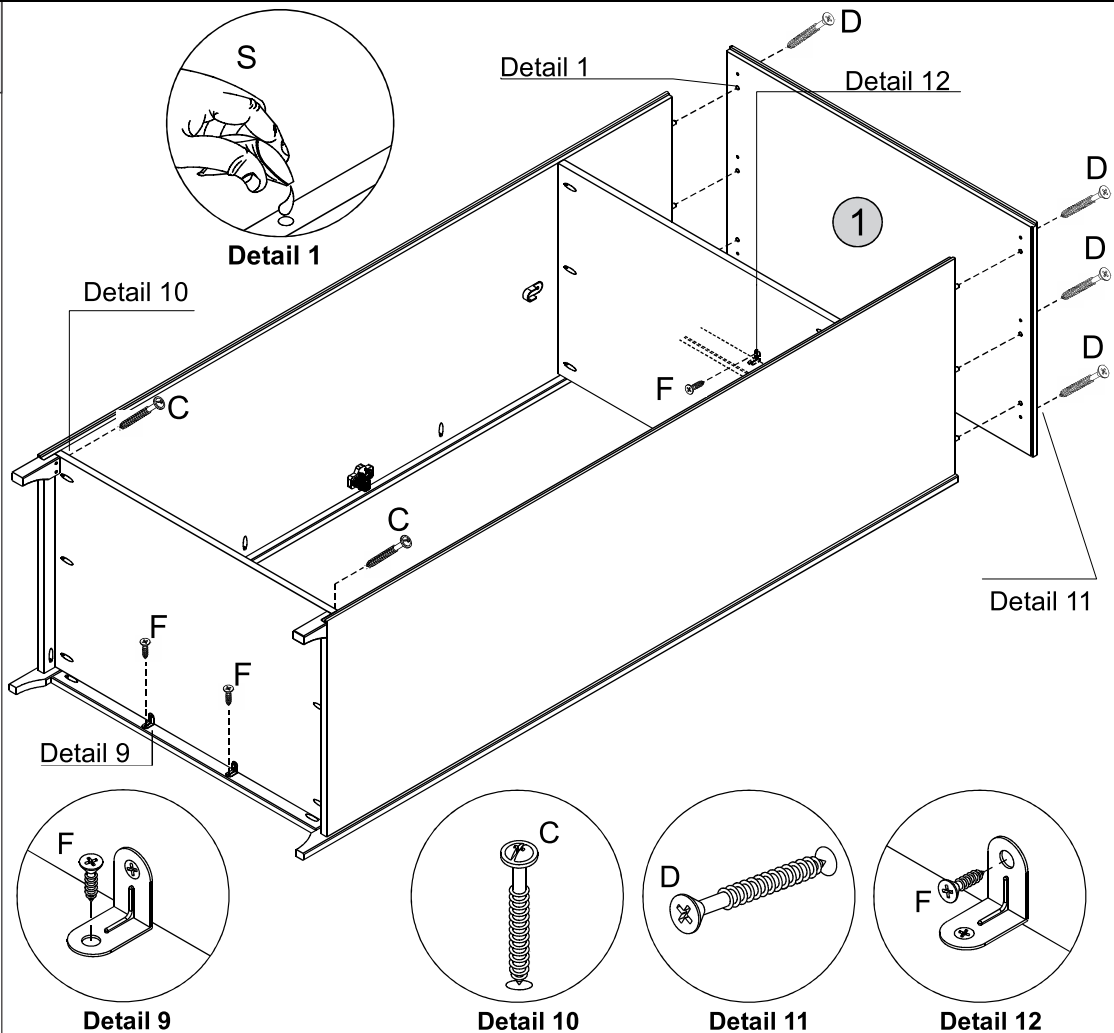
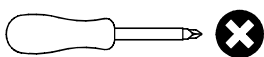

# STEP 11

**PARTS REQUIRED**

11 - BACK PANEL x1

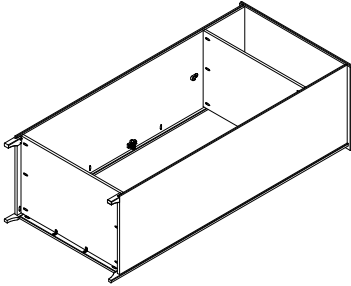

**HARDWARE REQUIRED**

K  40  
8 x 8

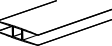
P  01  
Back Panel Strip

**TOOLS REQUIRED**

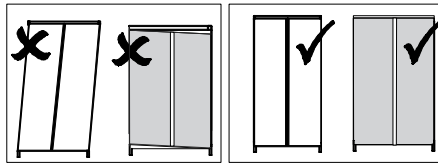
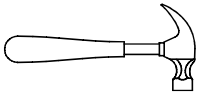

\* For your future reference  
Order Number should be here

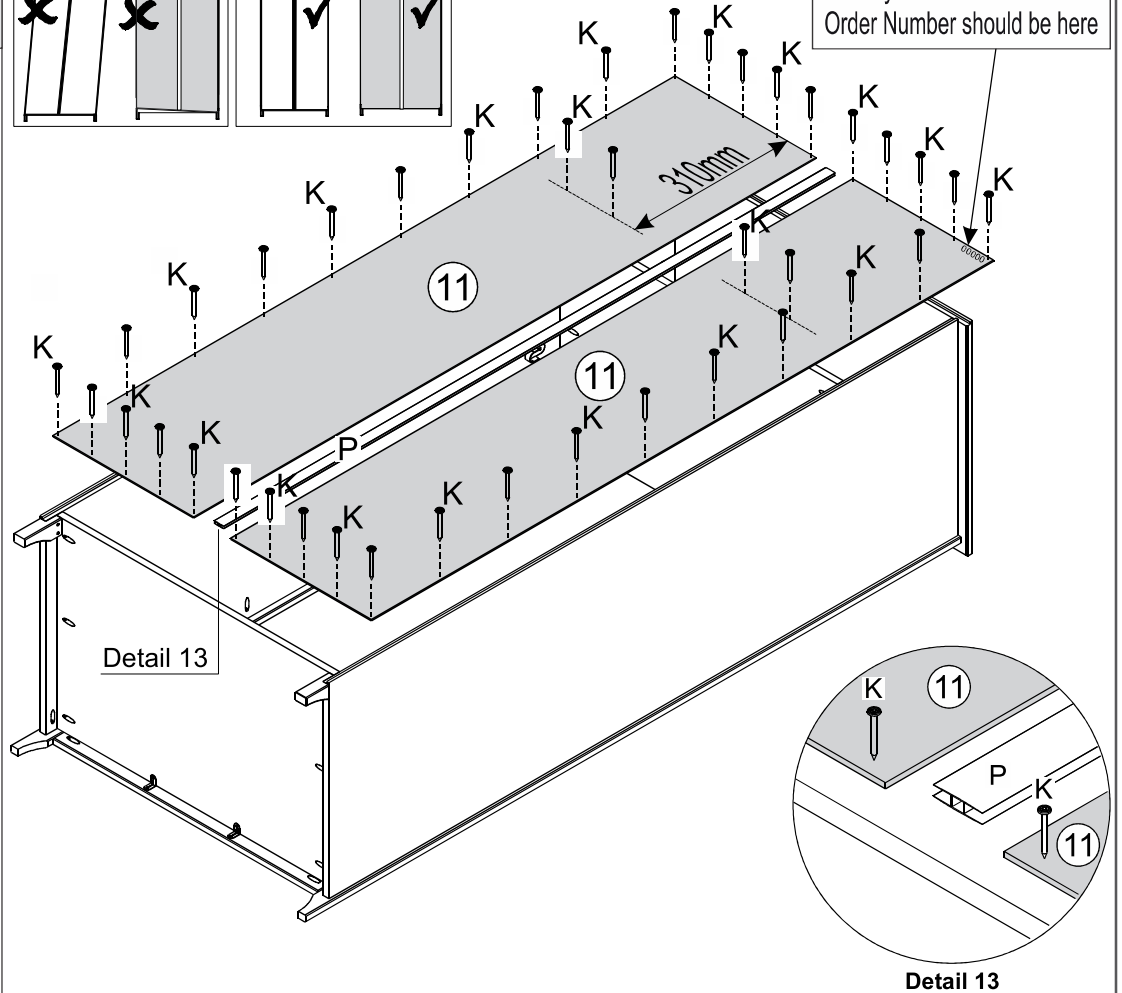

# STEP 12

**PARTS REQUIRED**

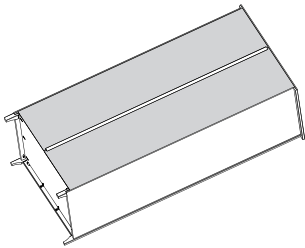

**HARDWARE REQUIRED**

**TOOLS REQUIRED**

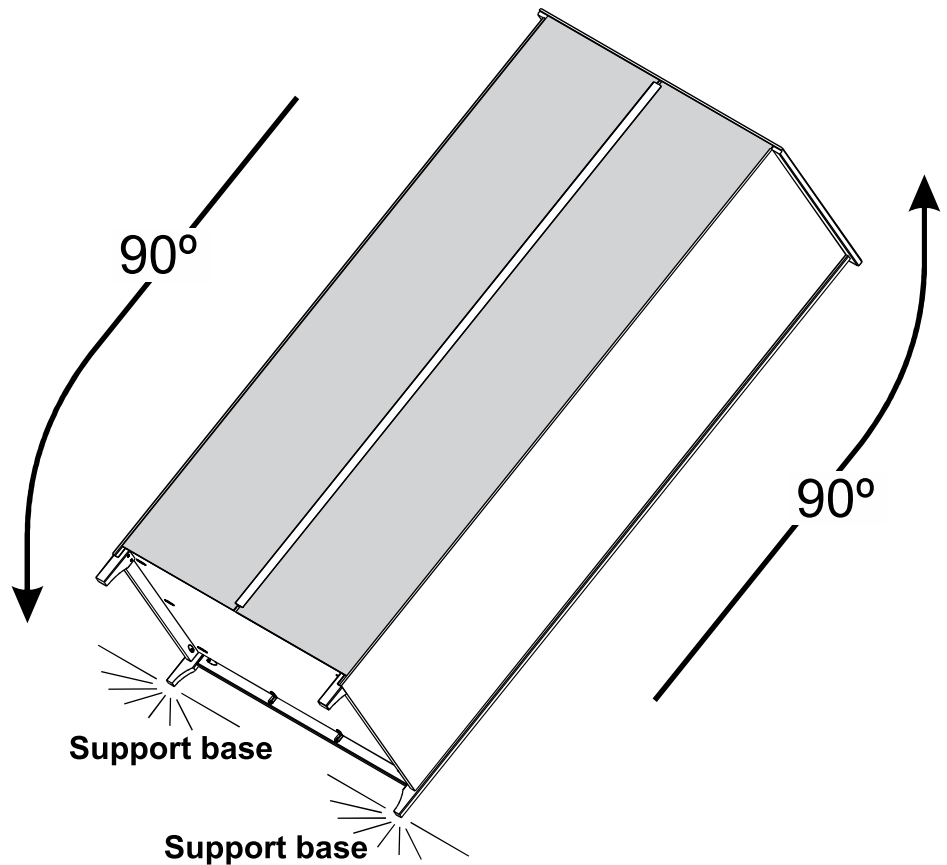





# STEP 13

## PARTS REQUIRED

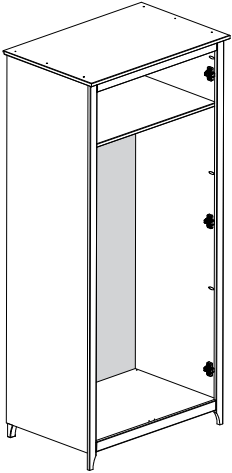
10 - HANGER x1



## HARDWARE REQUIRED

F  02  
Ø3.5 x 14mm

O  01

## TOOLS REQUIRED

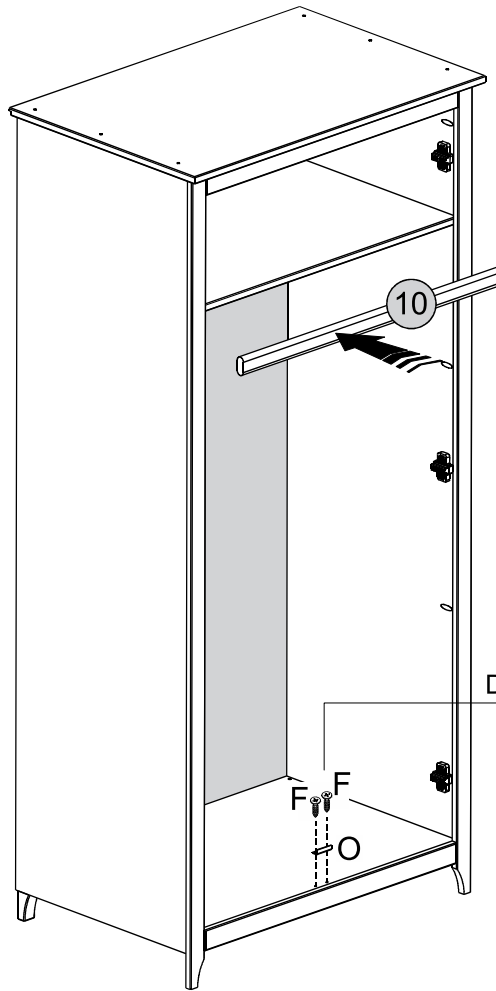
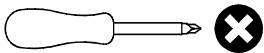

Detail 14

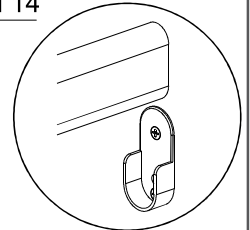

Detail 14

Detail 15

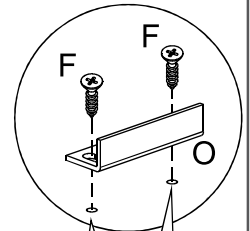

**Please note:  
Pre-marked  
Holes**

Detail 15

# STEP 14

## PARTS REQUIRED

13 - DOOR x2

## HARDWARE REQUIRED

F  12  
Ø3.5 x 14mm

G  06  
Hinge (Door) (6x)

## TOOLS REQUIRED

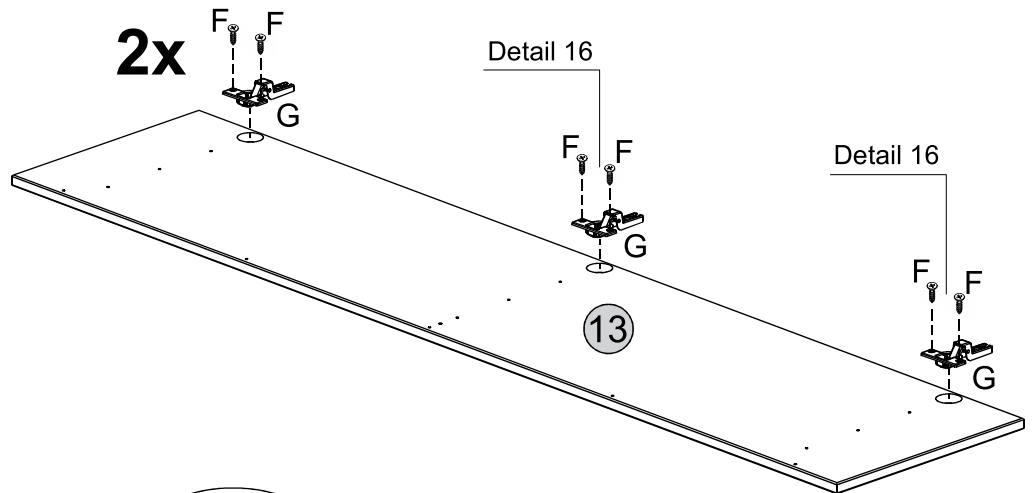
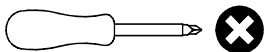

2x

Detail 16

Detail 16

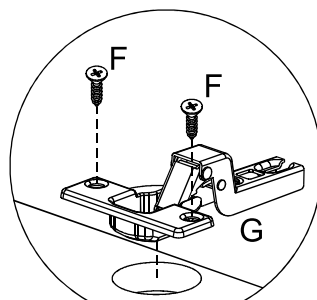

Detail 16

# STEP 15

**PARTS REQUIRED**

14 - DOOR CROSSBEAM x6

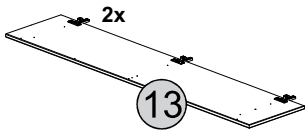

**HARDWARE REQUIRED**

E  18  
Ø4,0 x 25mm

**TOOLS REQUIRED**

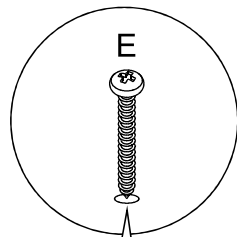
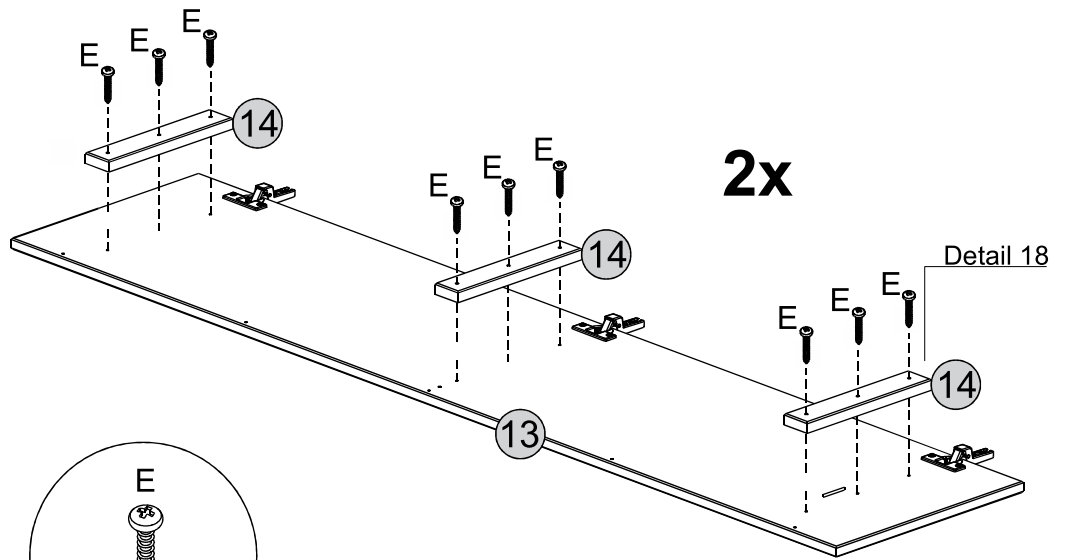
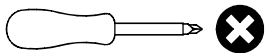

**Please note:  
Pre-marked  
Holes**

Detail 18

# STEP 16

**PARTS REQUIRED**

12 - DOOR STRIP x1

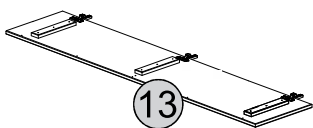

**HARDWARE REQUIRED**

F  05  
Ø3,5 x 14mm

**TOOLS REQUIRED**

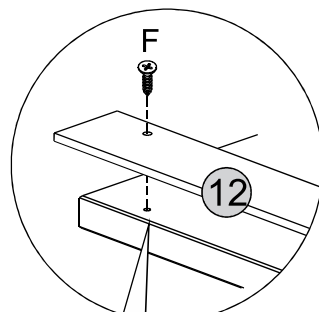
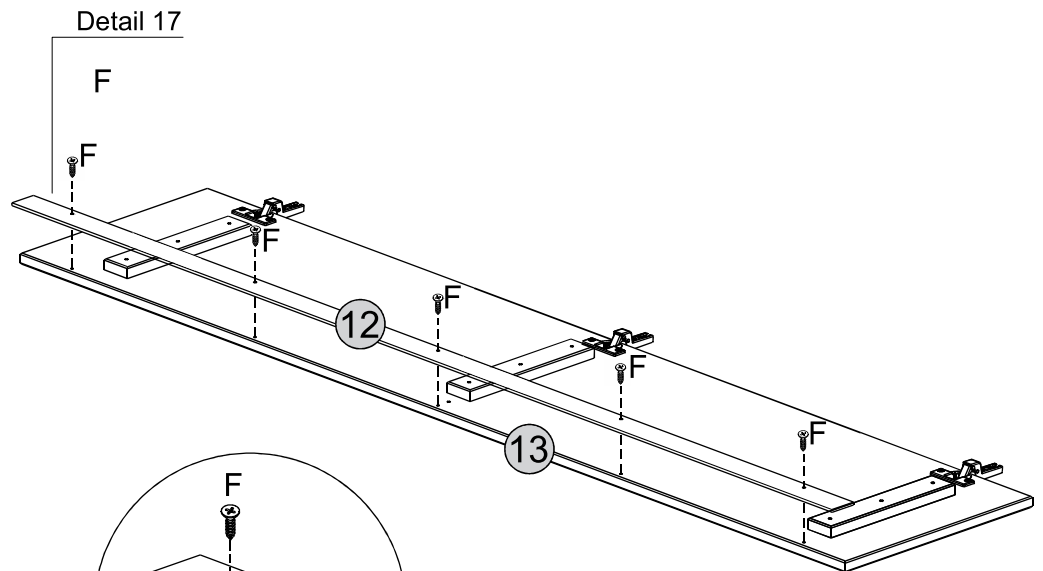
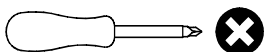

**Please note:  
Pre-marked  
Holes**

Detail 17

# STEP 17

## PARTS REQUIRED

13 - DOOR x1

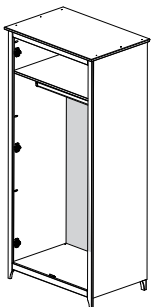

## HARDWARE REQUIRED

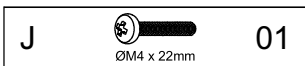
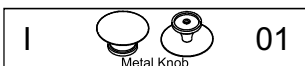

## TOOLS REQUIRED

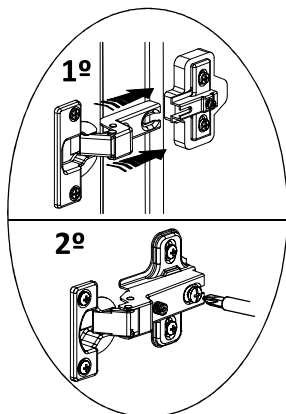
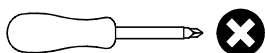

Detail 19

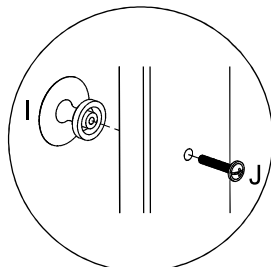

Detail 20

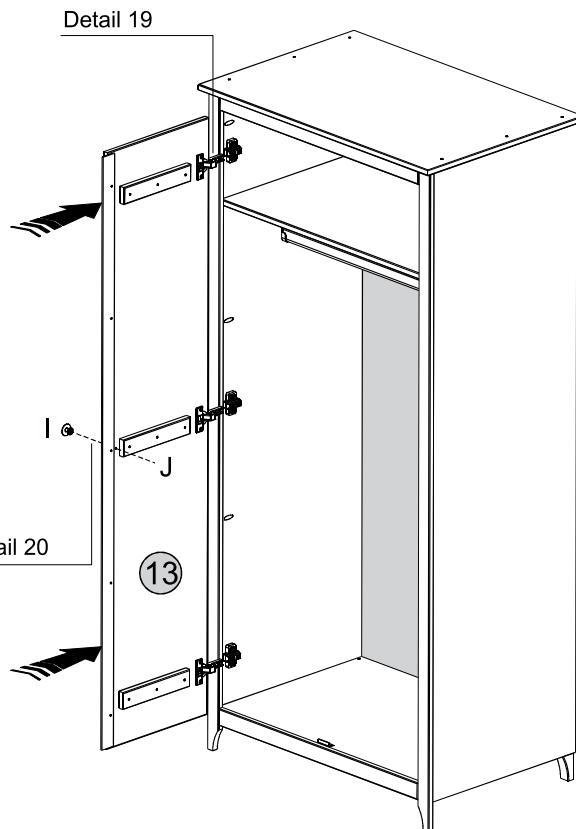

# STEP 18

## PARTS REQUIRED

13 - DOOR x1

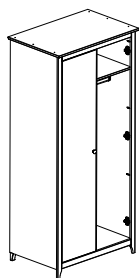

## HARDWARE REQUIRED

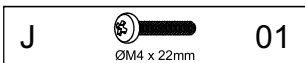
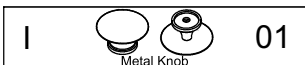

## TOOLS REQUIRED

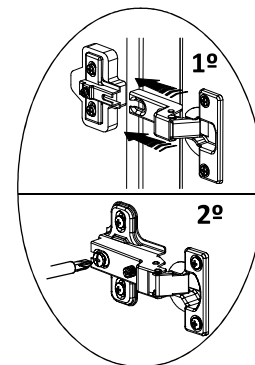
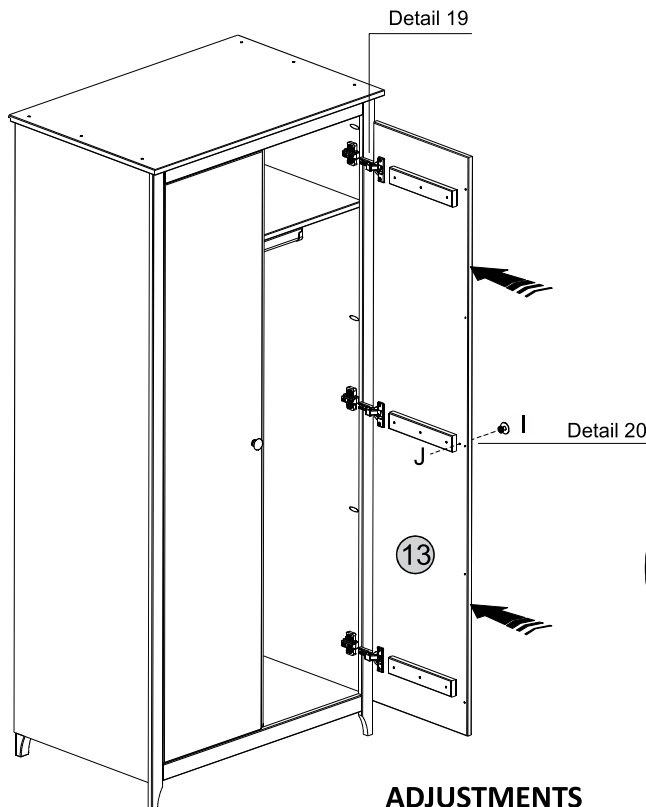
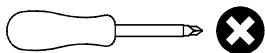

Detail 19

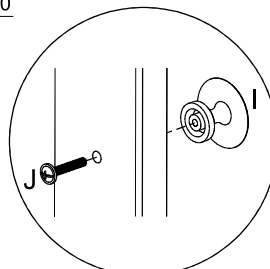

Detail 20

## ADJUSTMENTS

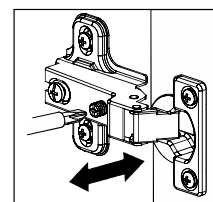
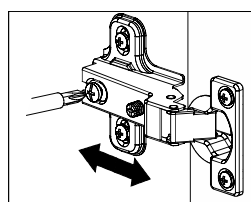
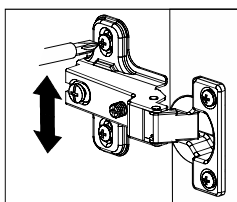





## WARNING

**Serious or fatal injuries can occur from furniture tipping over. To prevent the furniture from tipping over we recommend that it is permanently fixed to the wall.**

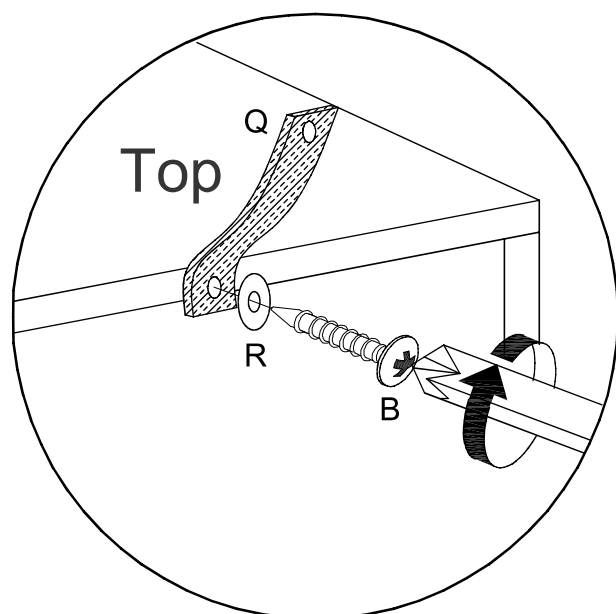
Wall fixings are not supplied with this product as different wall materials require different types of fixing devices.

Please make sure you use fixings suitable for the walls in your home.



B		01
	$\varnothing 3,5 \times 30\text{mm}$	
Q		01
	Strap	
R		02
	Washer	

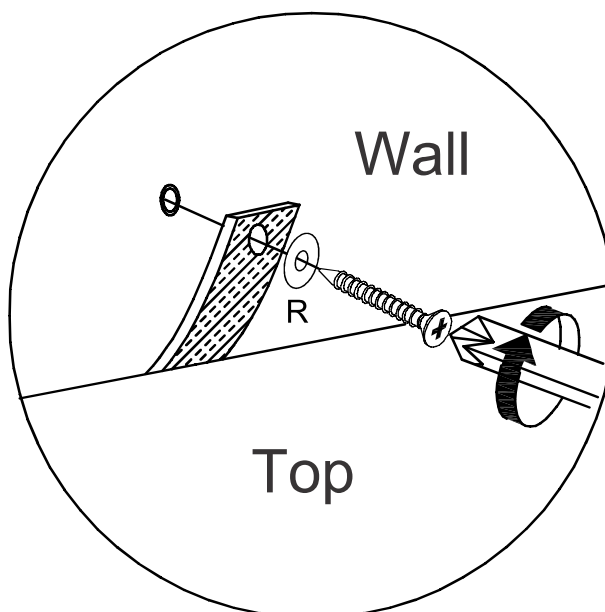
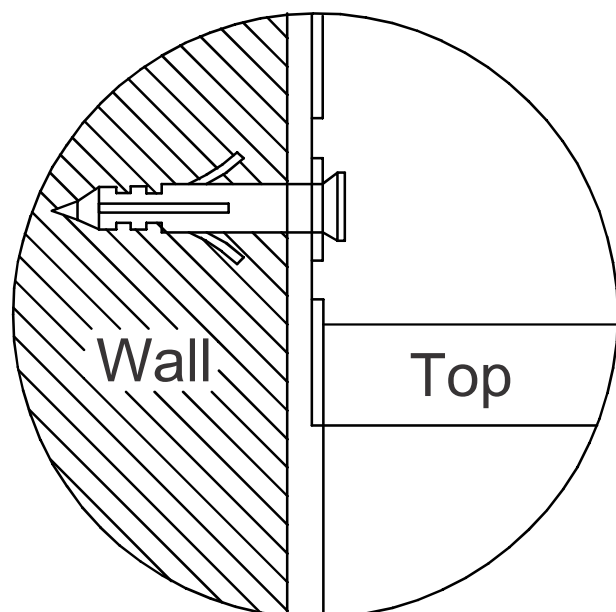

# OSLO 4 DRAWER CHEST ASSEMBLY INSTRUCTIONS



**IMPORTANT**  
**FOR DOMESTIC USE ONLY**  
PLEASE READ BEFORE YOU CONTINUE FURTHER

## CARE AND MAINTENANCE

After unpacking this product please keep the original packaging in case it needs to be returned for any reason.

- Please ensure all fittings and parts are present before commencing with assembly.
- Never drag or push products as this could cause damage to the joints making it inferior.
- We strongly recommend that you keep children away from your work area.
- We recommend that you lay a blanket or sheet on the floor to avoid damage to both your floor and the product.
- Assemble this product as close to its final position as possible.
- Do not place this product next to a radiator or in direct sunlight.
- Do not drag or push items across your high gloss furniture as this may cause the surface to scratch
- Wood is a natural product and may expand if subjected to damp and may shrink or crack if subjected to heat. Therefore it is recommended that room temperature is maintained, with no sudden temperature fluctuations.
- Make sure any spillage is wiped off immediately.
- Do not place hot or chilled items directly on to the surface, use a place mat or marking will occur.
- For general cleaning use a soft cotton or micro fibre cloth, and do not use detergents of any kind.
- From time to time it may be necessary to tighten fittings, regular inspections should be carried out.
- Do not place on a wet or damp floor as staining may occur to your floor.

## TOOLS REQUIRED

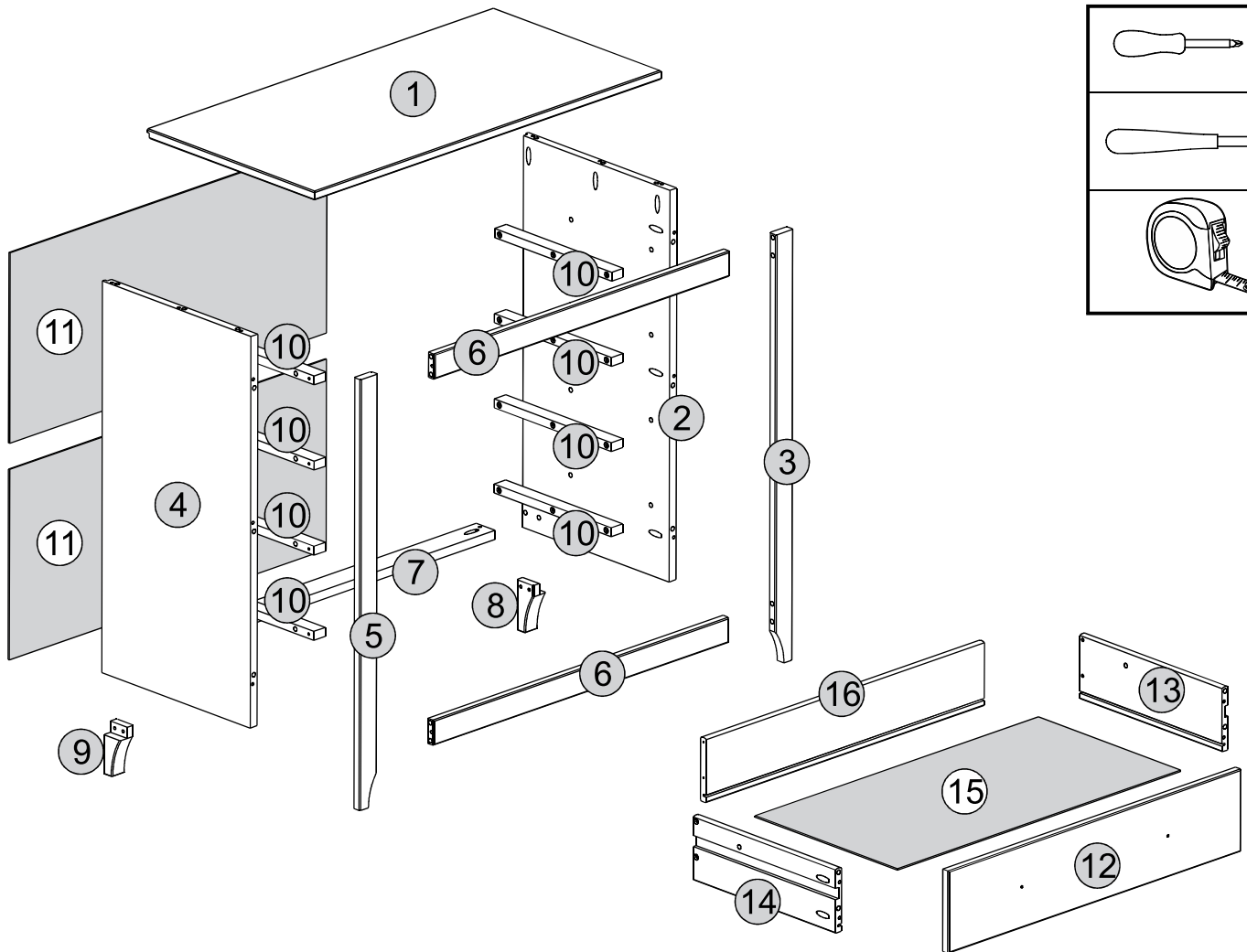
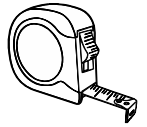
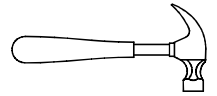
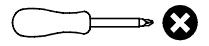







## PARTS LIST

***Please Note:***

The below parts have all been stamped with the part number to help identify them during assembly.

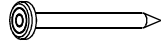
<b>Part Number</b>	<b>Part Code</b>	<b>Part Description</b>	<b>Quantity</b>	<b>Carton</b>
1	S100-102-172-MY1-01	Top Panel	1	1/1
2	S100-102-172-MY1-02	Right Side Panel	1	1/1
3	S100-102-172-MY1-03	Right Front Upright	1	1/1
4	S100-102-172-MY1-04	Left Side Panel	1	1/1
5	S100-102-172-MY1-05	Left Front Upright	1	1/1
6	S100-102-172-MY1-06	Front Crossbeam	2	1/1
7	S100-102-172-MY1-07	Back Crossbeam	1	1/1
8	S100-102-172-MY1-08	Right Back Foot	1	1/1
9	S100-102-172-MY1-09	Left Back Foot	1	1/1
10	S100-102-172-MY1-10	Drawer Runner	8	1/1
11	S100-102-172-MY1-11	Back Panel	2	1/1
12	S100-102-172-MY1-12	Drawer Front	4	1/1
13	S100-102-172-MY1-13	Right Drawer Side	4	1/1
14	S100-102-172-MY1-14	Left Drawer Side	4	1/1
15	S100-102-172-MY1-15	Drawer Bottom	4	1/1
16	S100-102-172-MY1-16	Drawer Back Panel	4	1/1

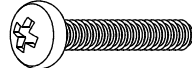
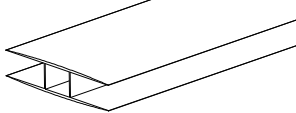
**FITTINGS LIST**

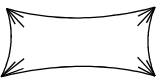
<p><b>A</b></p>  <p>Dowel Ø8,0 x 30mm (64x)</p> <p>+/2</p>	<p><b>B</b></p>  <p>Screw Ø3,5 x 30mm (77x)</p> <p>+/2</p>	<p><b>C</b></p>  <p>Flan Head Screw Ø4,0 x 35mm (6x)</p> <p>+/1</p>	<p><b>D</b></p>  <p>Nail 8 x 8 (26x)</p> <p>+/2</p>
<p><b>E</b></p>  <p>Metal Knob (8x)</p>	<p><b>F</b></p>  <p>Screw ØM4 x 22mm (8x)</p> <p>+/1</p>	<p><b>G</b></p>  <p>Back Panel Strip 695mm (1x)</p>	<p><b>H</b></p>  <p>Washer (2x)</p> <p>+/1</p>
<p><b>I</b></p>  <p>Strap (1x)</p>	<p><b>J</b></p>  <p>Glue (1x)</p>		

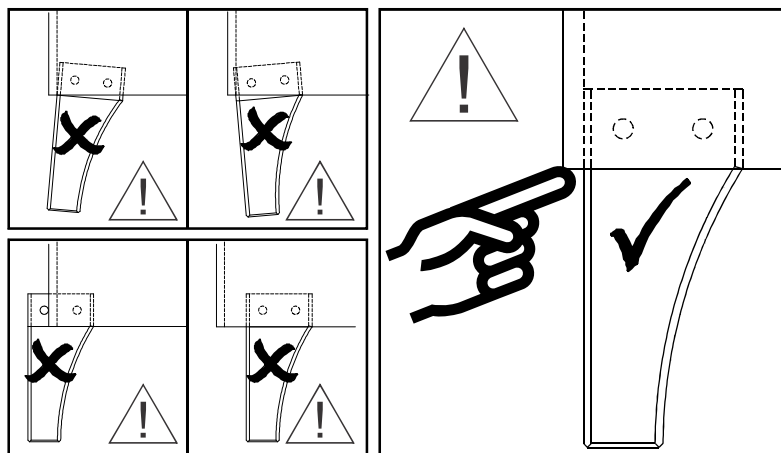

**PLEASE USE THE ABOVE EXAMPLE TO ASSEMBLE THE FEET ON STEP 2.**



# STEP 1

## PARTS REQUIRED

2 - RIGHT SIDE PANEL x1

4 - LEFT SIDE PANEL x1

## HARDWARE REQUIRED

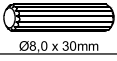
A  12  
Ø8.0 x 30mm

J  01  
Glue

## TOOLS REQUIRED

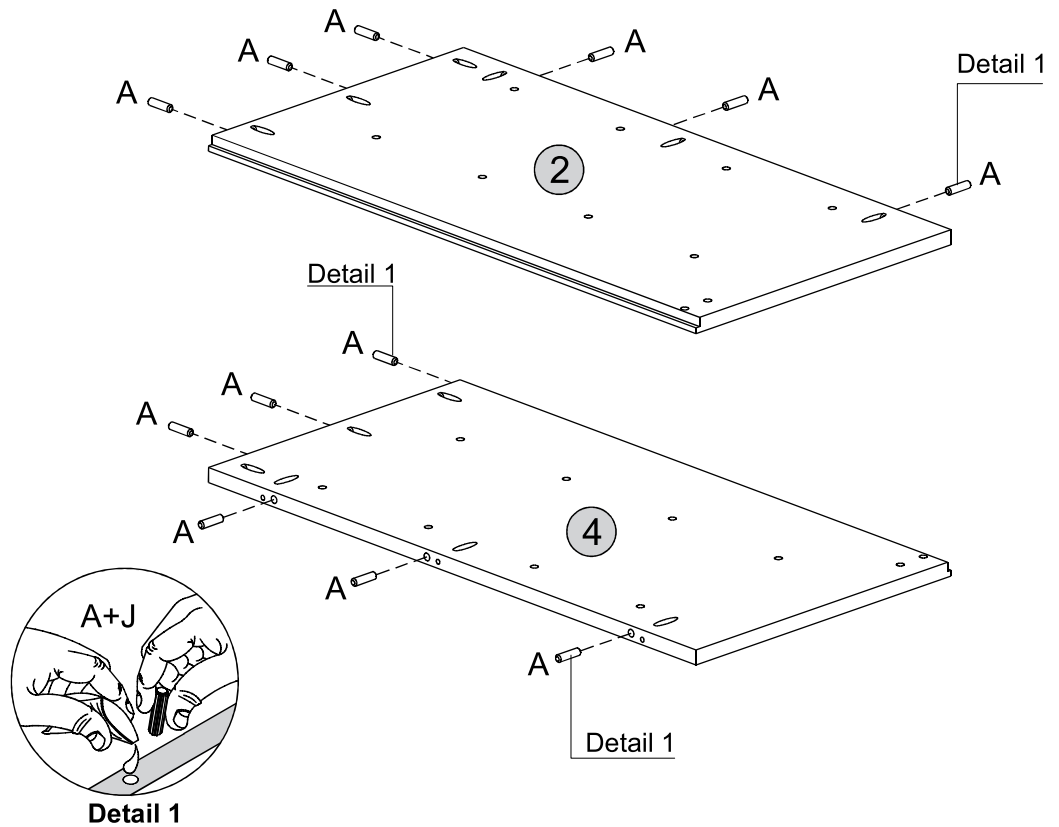
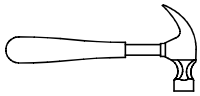

# STEP 2

## PARTS REQUIRED

2 - RIGHT SIDE PANEL x1

4 - LEFT SIDE PANEL x1

8 - RIGHT BACK FOOT x1

9 - LEFT BACK FOOT x1

## HARDWARE REQUIRED

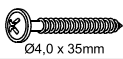
C  04  
Ø4.0 x 35mm

## TOOLS REQUIRED

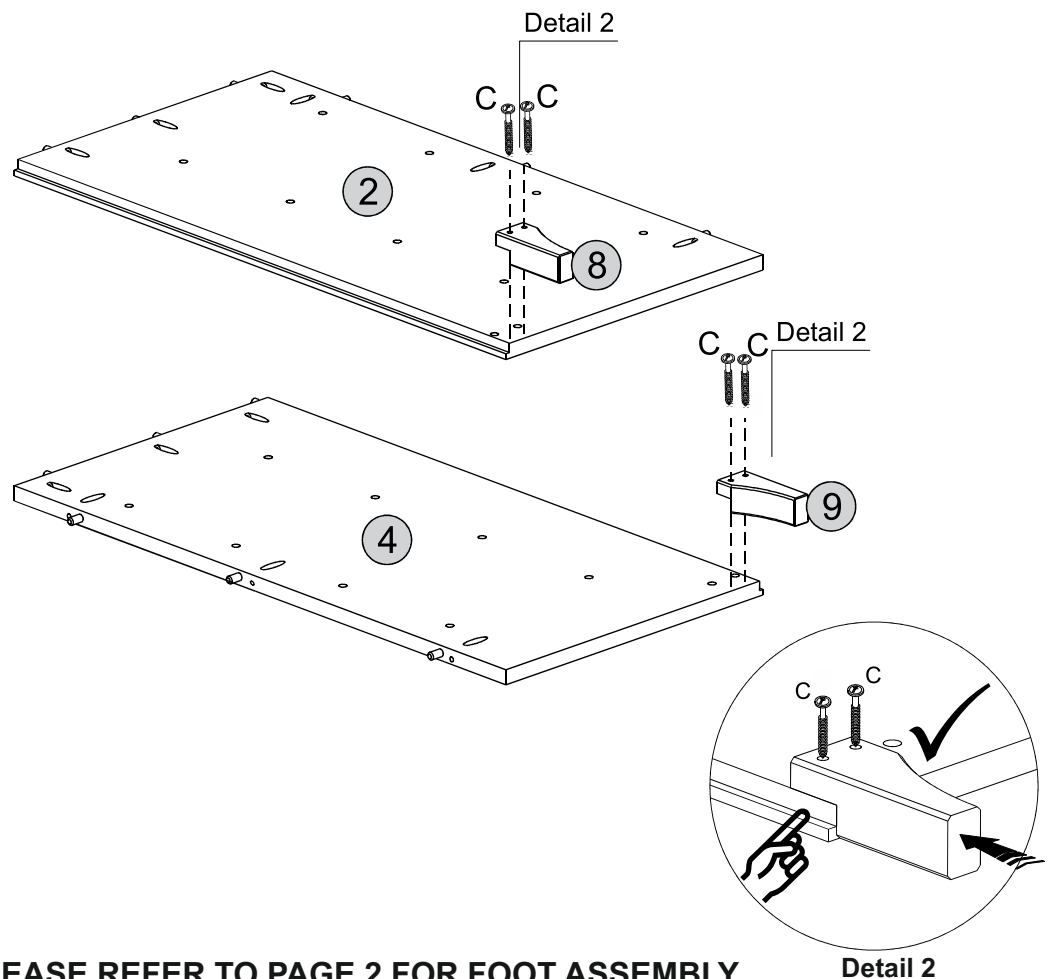
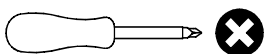

PLEASE REFER TO PAGE 2 FOR FOOT ASSEMBLY.

# STEP 3

## PARTS REQUIRED

3 - RIGHT FRONT UPRIGHT x1

5 - LEFT FRONT UPRIGHT x1

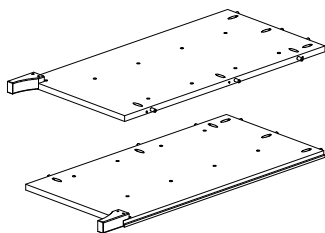

## HARDWARE REQUIRED

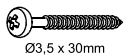
B  06  
Ø3.5 x 30mm

J  01  
Glue

## TOOLS REQUIRED

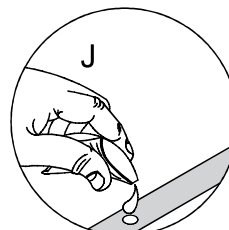
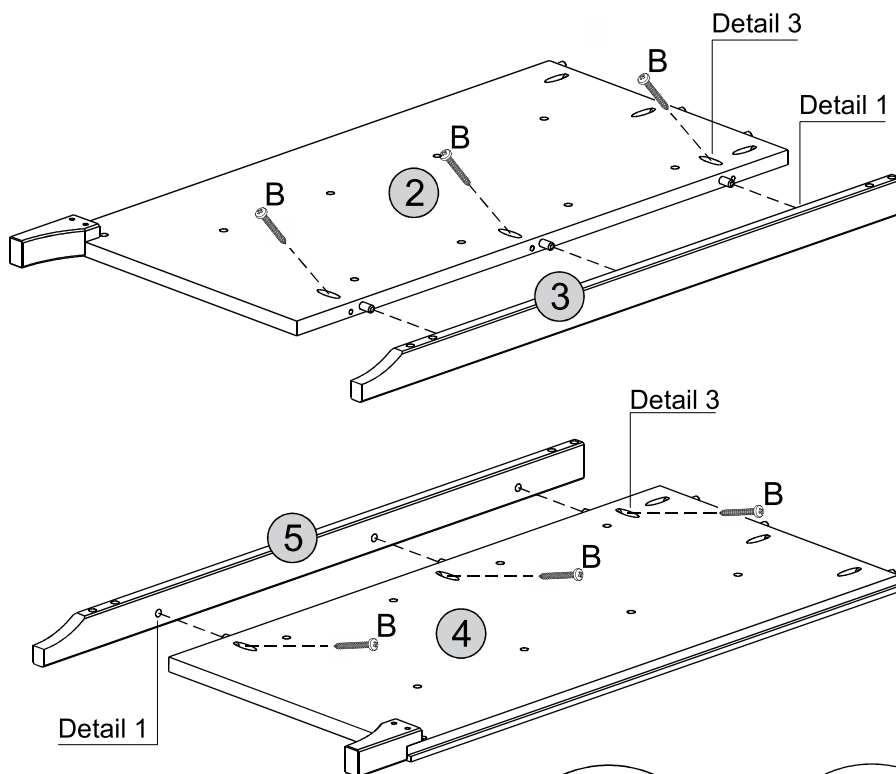
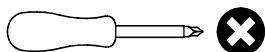

Detail 1

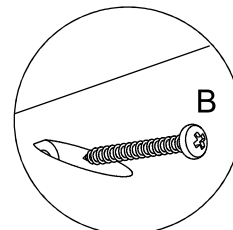

Detail 3

# STEP 4

## PARTS REQUIRED

6 - FRONT CROSSBEAM x2

7 - BACK CROSSBEAM x1

## HARDWARE REQUIRED

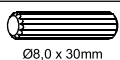
A  12  
Ø8.0 x 30mm

J  01  
Glue

## TOOLS REQUIRED

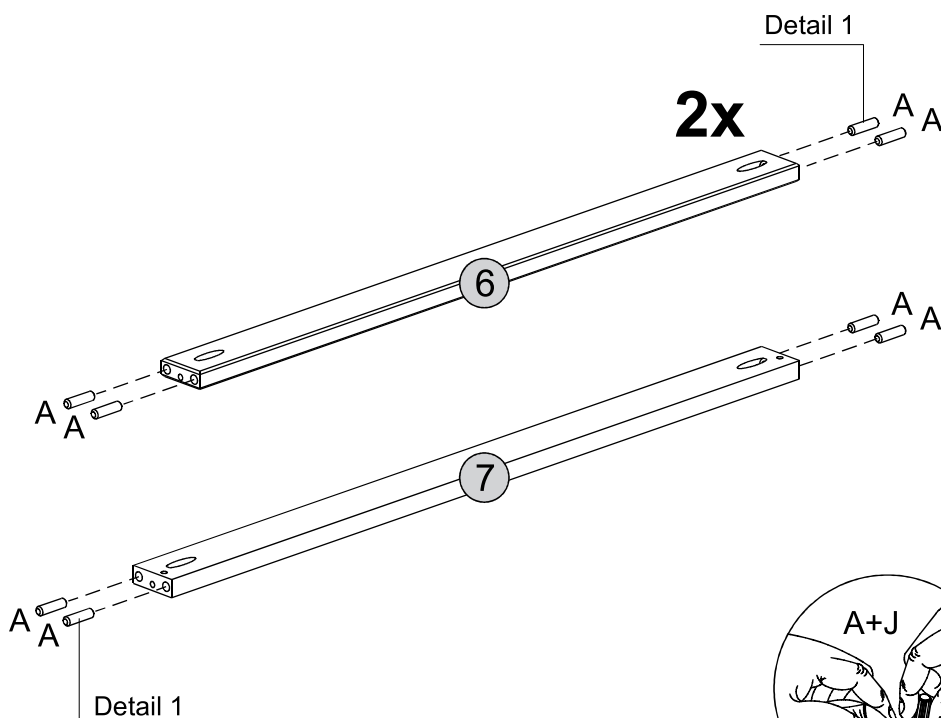
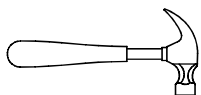

Detail 1

2x

Detail 1

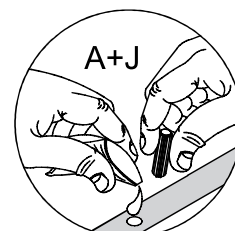

Detail 1

# STEP 5

## PARTS REQUIRED

6 - FRONT CROSSBEAM x2

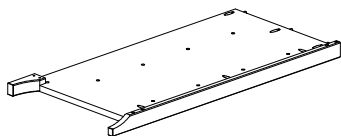

## HARDWARE REQUIRED

B  02  
Ø3,5 x 30mm

J  01  
Glue

## TOOLS REQUIRED

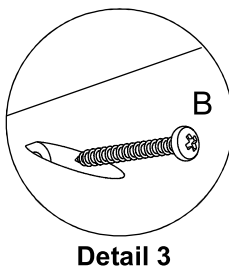
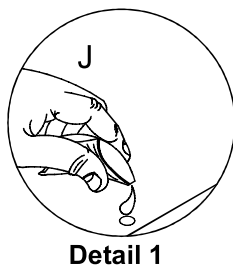
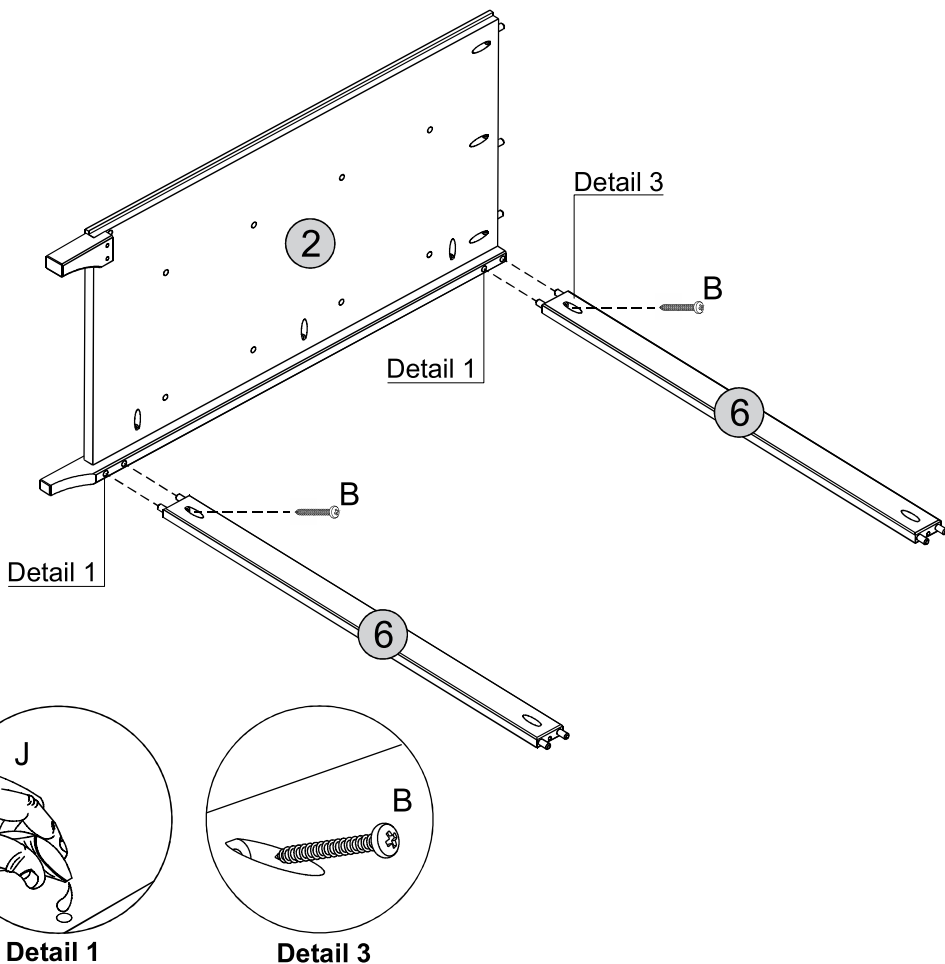
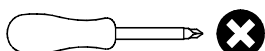

# STEP 6

## PARTS REQUIRED

7 - BACK CROSSBEAM x2

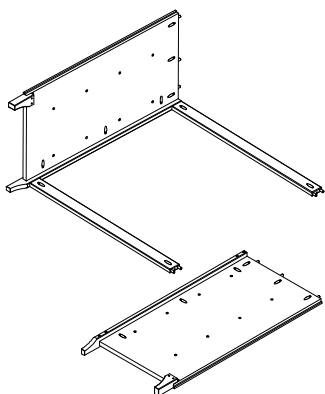

## HARDWARE REQUIRED

B  04  
Ø3,5 x 30mm

J  01  
Glue

## TOOLS REQUIRED

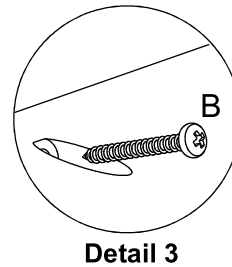
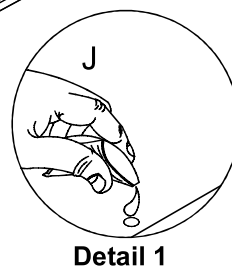
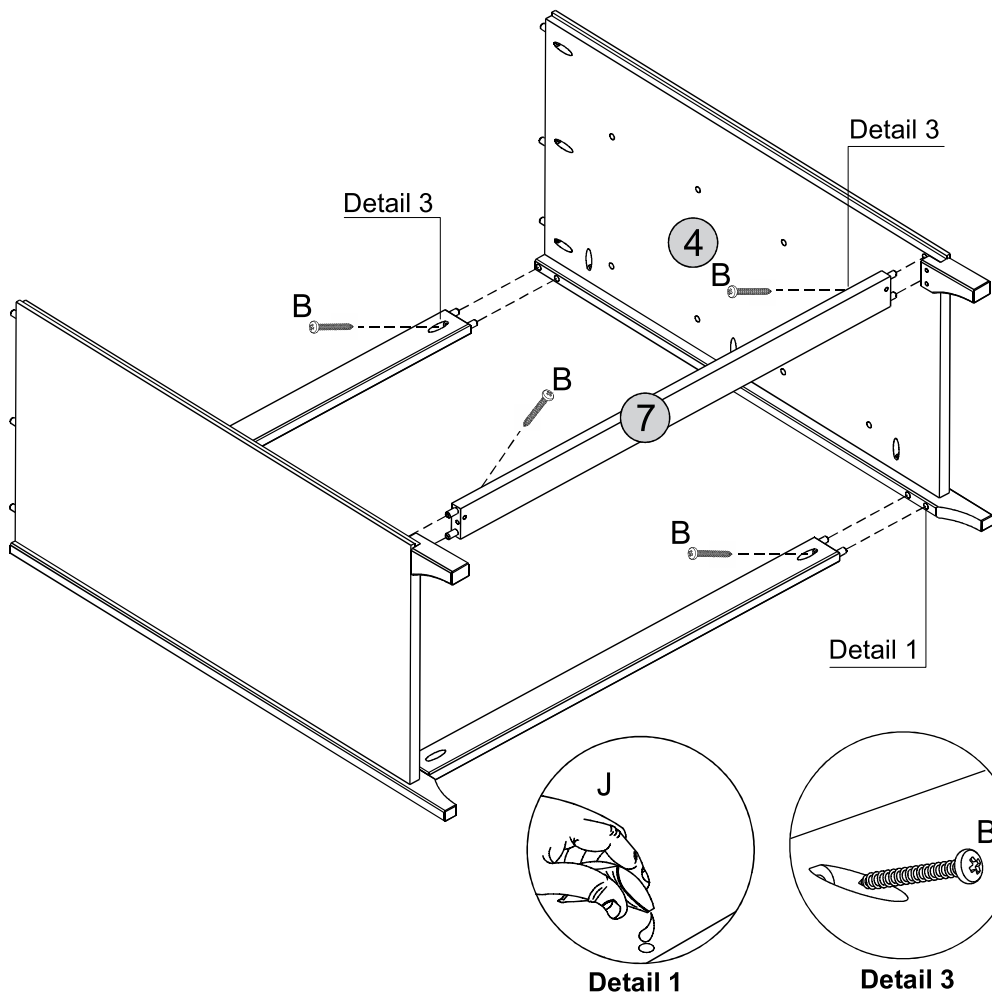
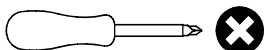

# STEP 7

## PARTS REQUIRED

1 - TOP PANEL x1

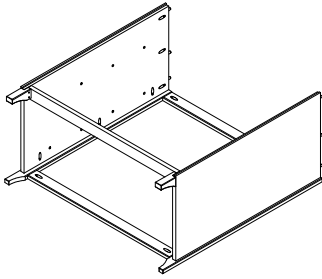

## HARDWARE REQUIRED

B  06  
Ø3,5 x 30mm

C  02  
Ø4,0 x 35mm

J  01  
Glue

## TOOLS REQUIRED

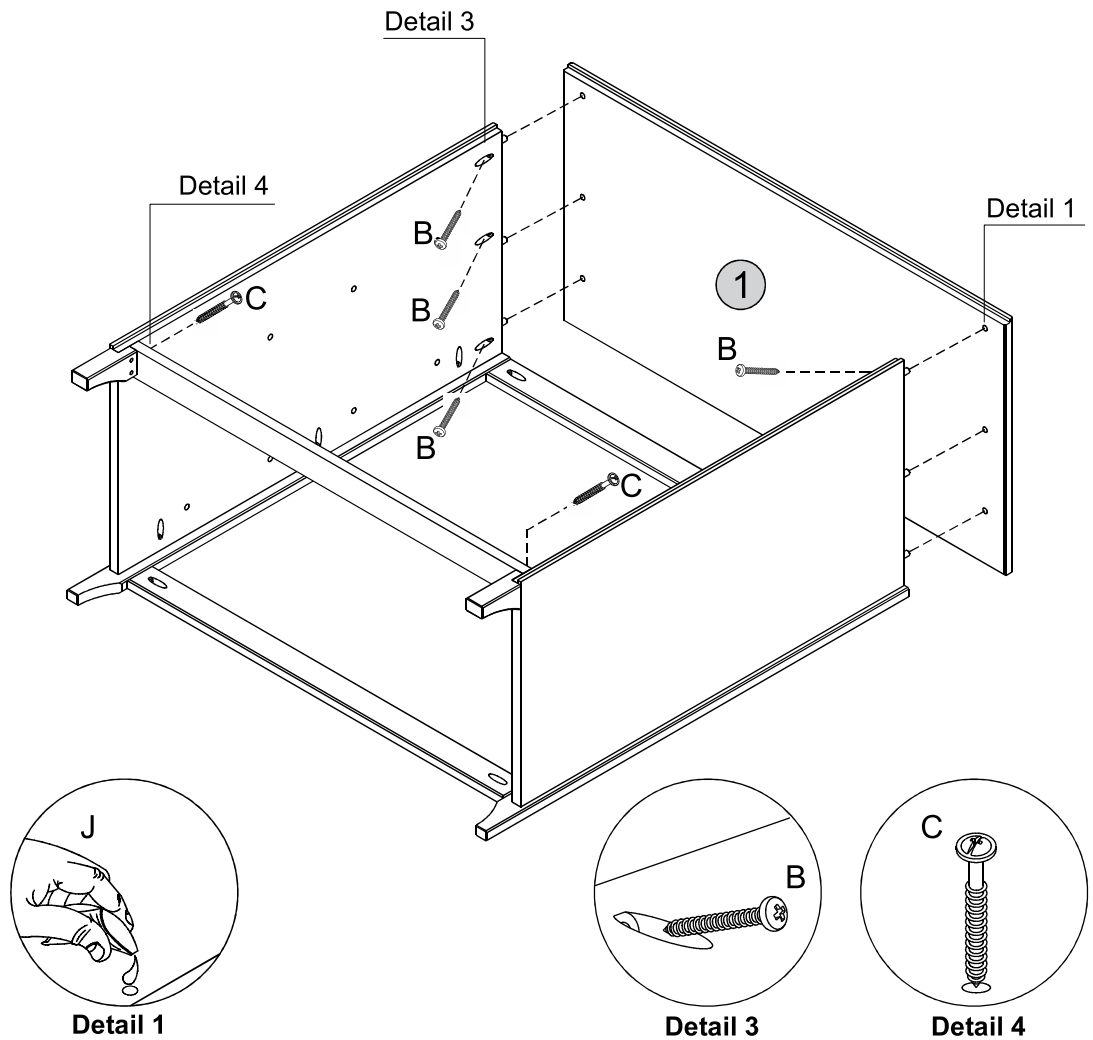
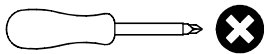

# STEP 8

## PARTS REQUIRED

10 - DRAWER RUNNER x8

## HARDWARE REQUIRED

A  16  
Ø8,0 x 30mm

J  01  
Glue

## TOOLS REQUIRED

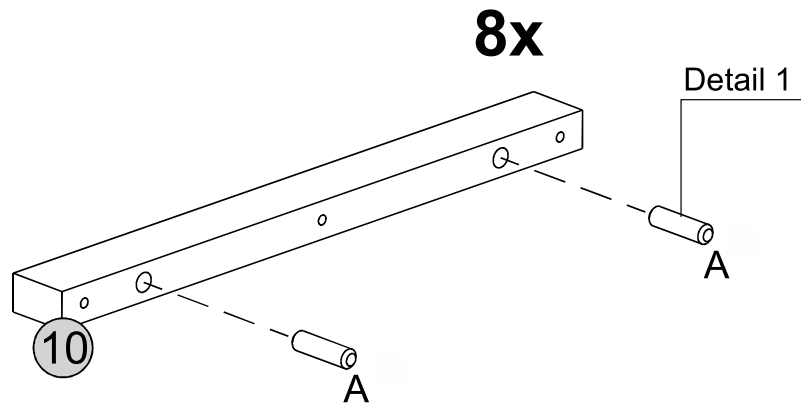
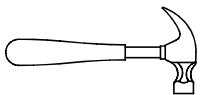

# STEP 9

## PARTS REQUIRED

10 - DRAWER RUNNER x8

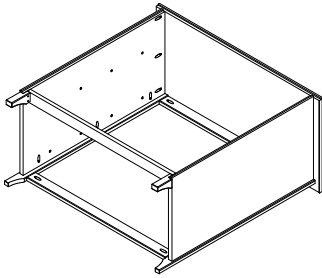

## HARDWARE REQUIRED

B  24  
Ø3,5 x 30mm

J  01  
Glue

## TOOLS REQUIRED

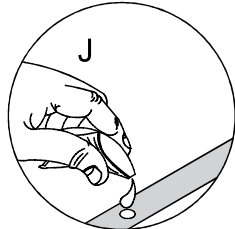
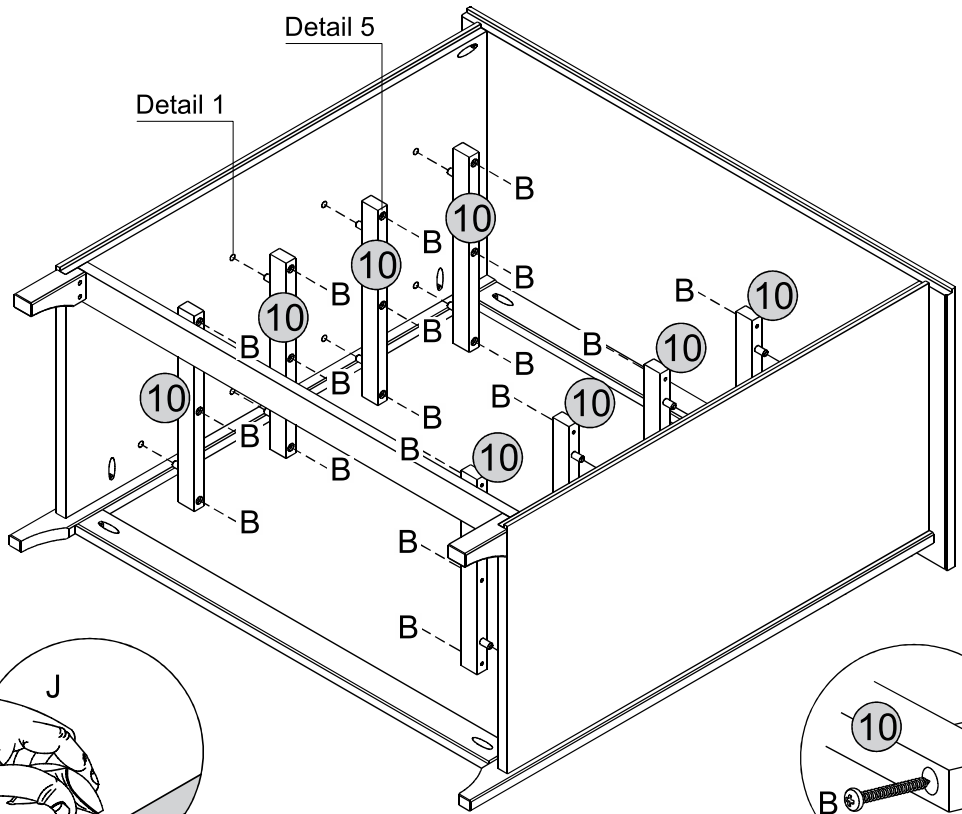
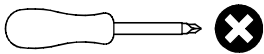

Detail 1

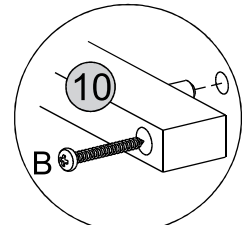

Detail 5

# STEP 10

## PARTS REQUIRED

11 - BACK PANEL x2

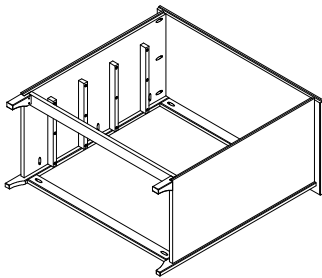

## HARDWARE REQUIRED

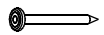
D  26  
8 x 8

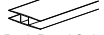
G  01  
Back Panel Strip

## TOOLS REQUIRED

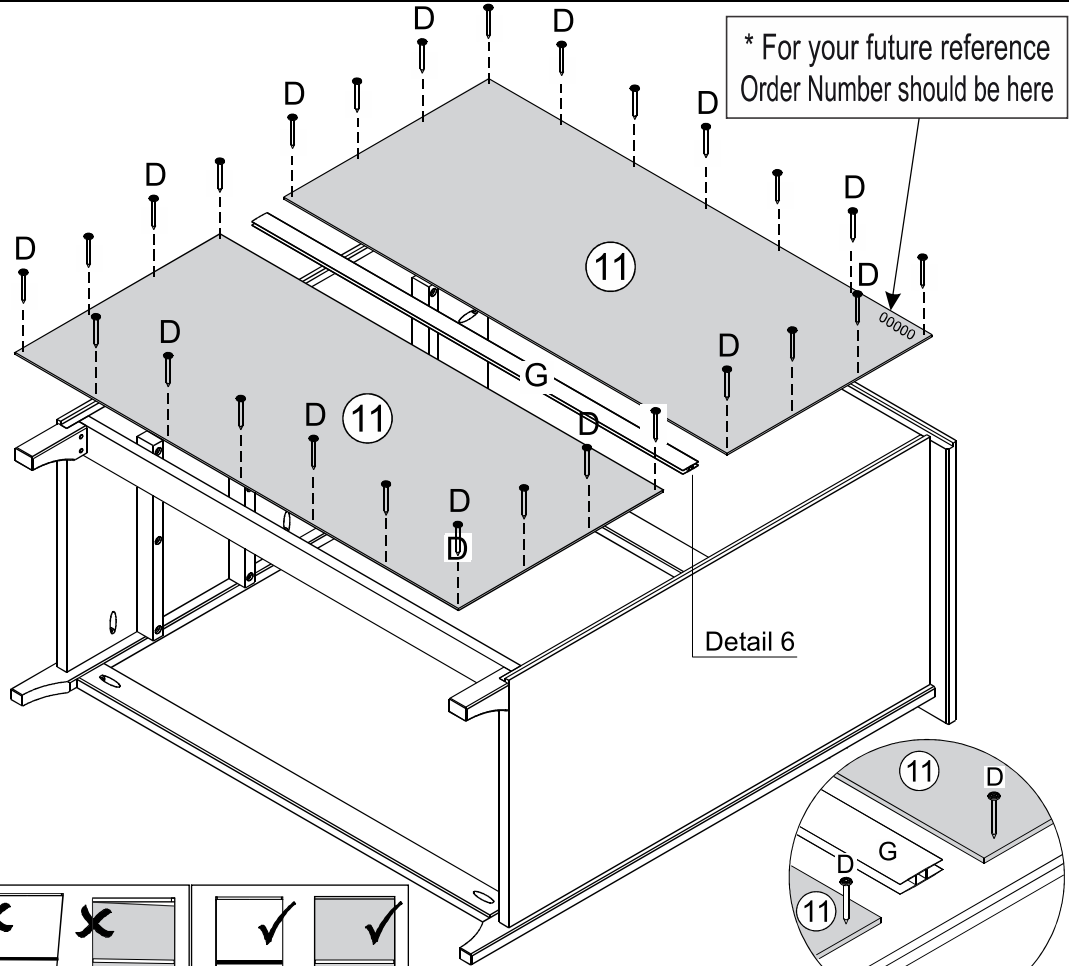
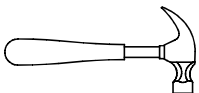

\* For your future reference  
Order Number should be here

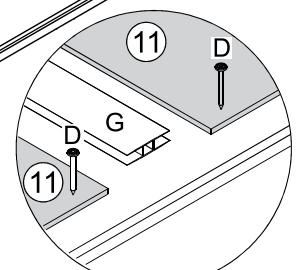

Detail 6

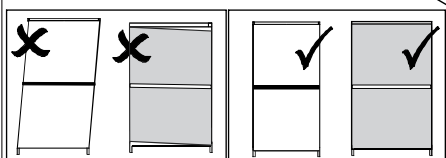

# STEP 11

PARTS REQUIRED

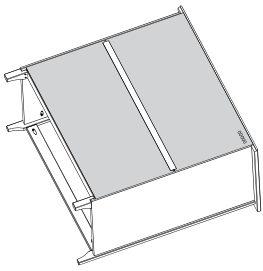

HARDWARE REQUIRED

TOOLS REQUIRED

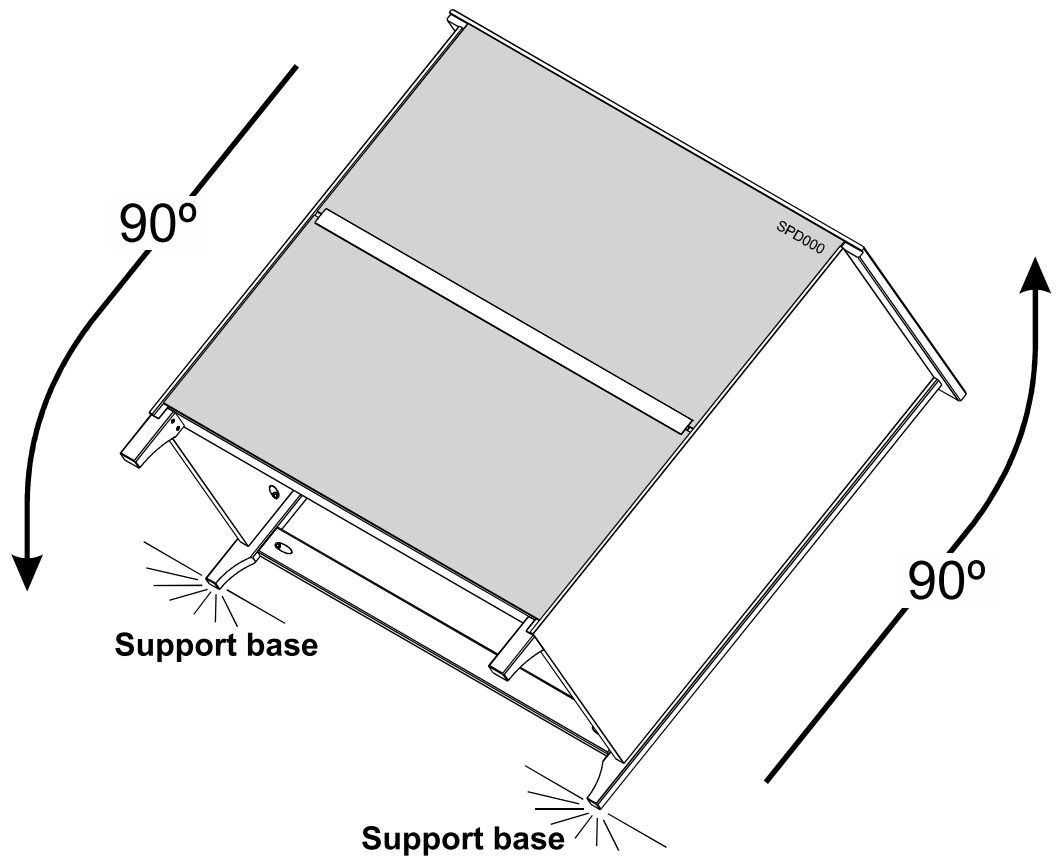

# STEP 12

PARTS REQUIRED

13 - RIGHT DRAWER SIDE x4

14 - LEFT DRAWER SIDE x4

HARDWARE REQUIRED

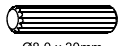
A  16  
Ø8,0 x 30mm

J  01  
Glue

TOOLS REQUIRED

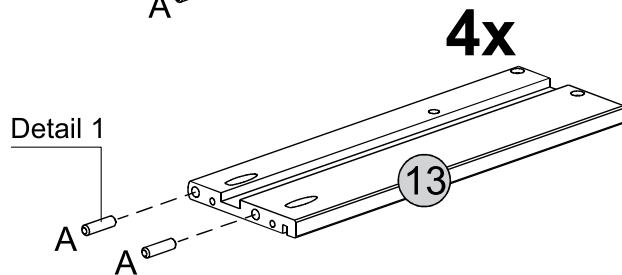
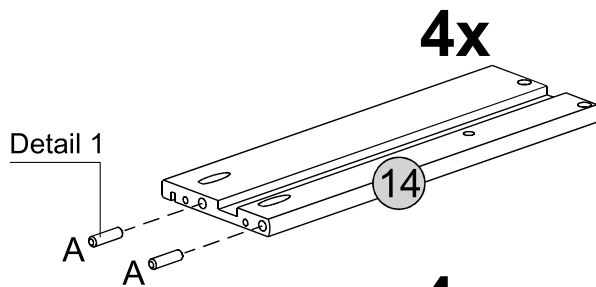
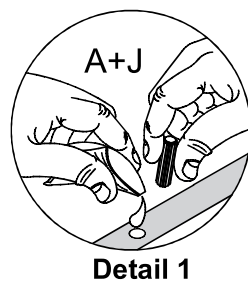
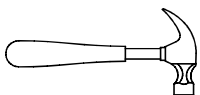

# STEP 13

## PARTS REQUIRED

12 - DRAWER FRONT x4

13 - RIGHT DRAWER SIDE x4

14 - LEFT DRAWER SIDE x4

## HARDWARE REQUIRED

B  16  
Ø3,5 x 30mm

J  01  
Glue

## TOOLS REQUIRED

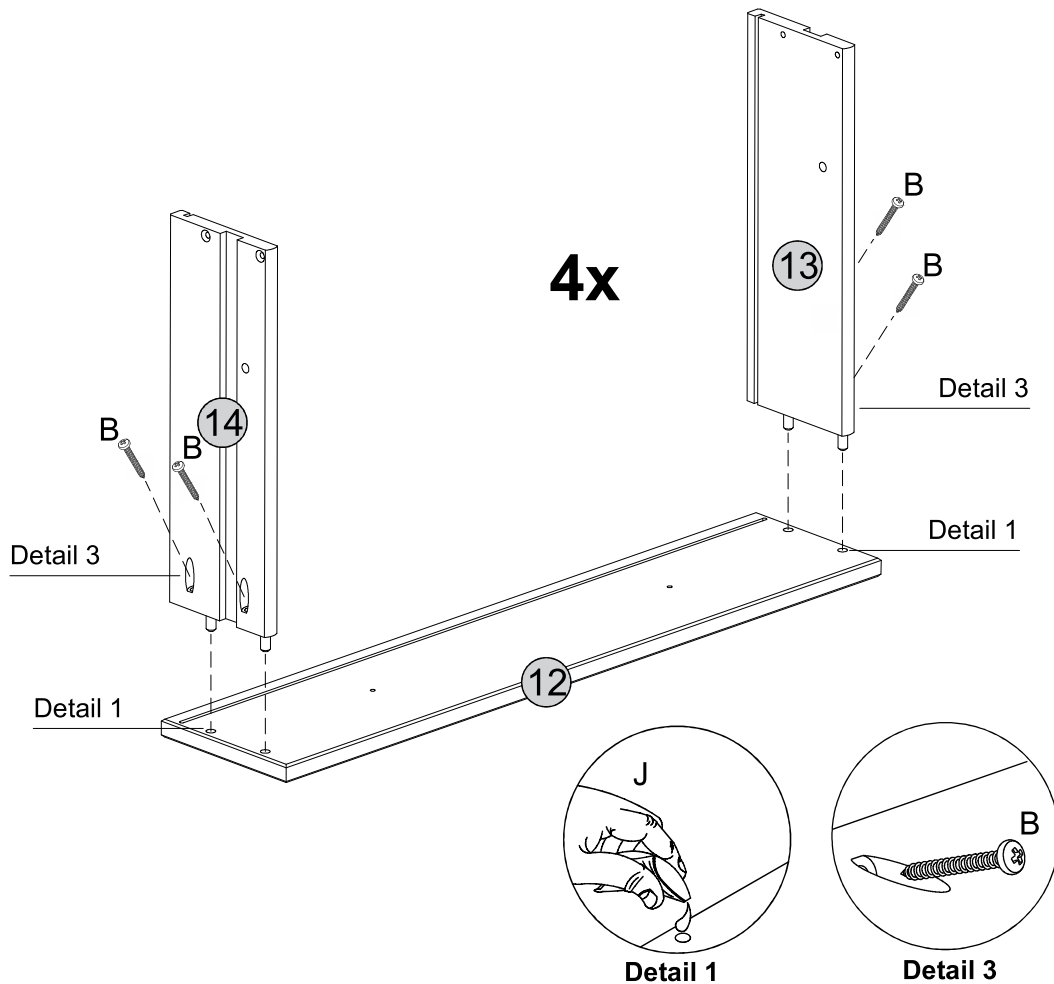
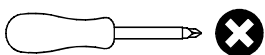

# STEP 14

## PARTS REQUIRED

15 - DRAWER BOTTOM x4

16 - DRAWER BACK PANEL x4

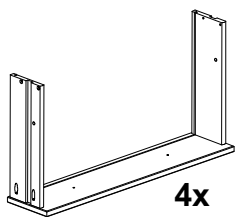

## HARDWARE REQUIRED

B  16  
Ø3,5 x 30mm

## TOOLS REQUIRED

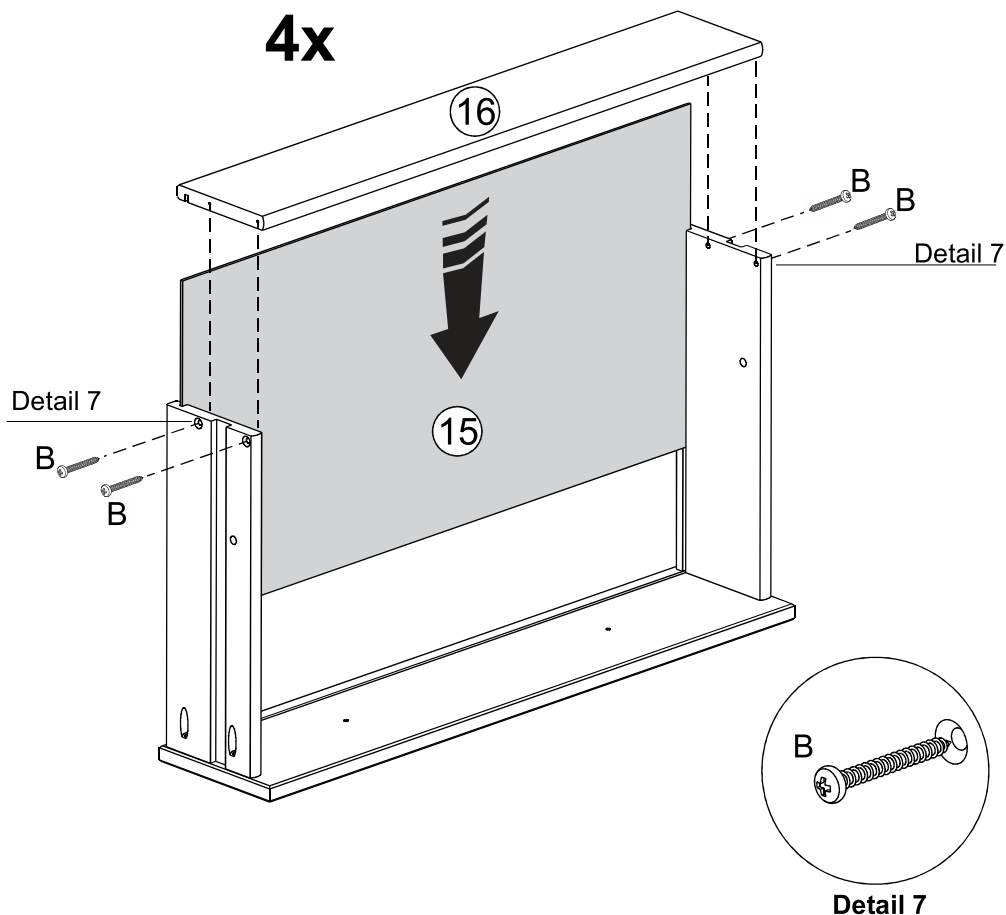
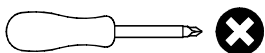



# STEP 15

**PARTS REQUIRED**

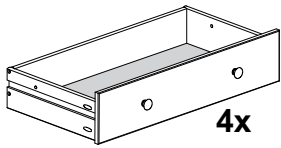

**HARDWARE REQUIRED**

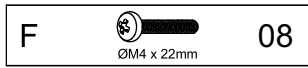
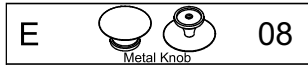

**TOOLS REQUIRED**

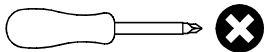

4x

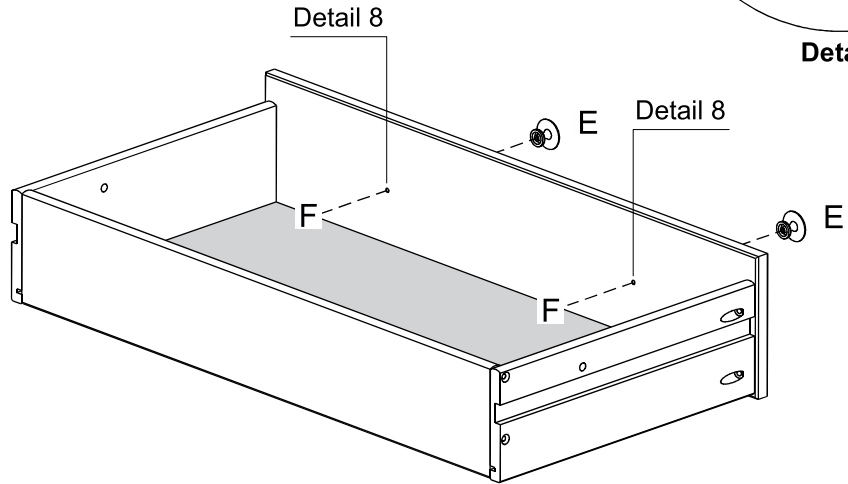

# STEP 16

**PARTS REQUIRED**

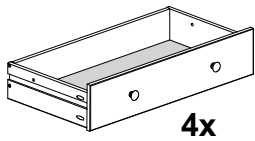
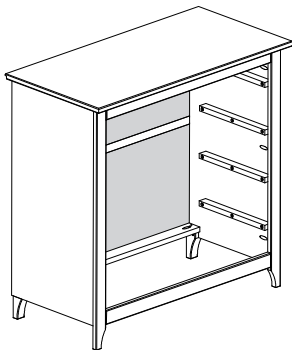

**HARDWARE REQUIRED**

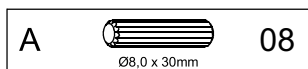

**TOOLS REQUIRED**

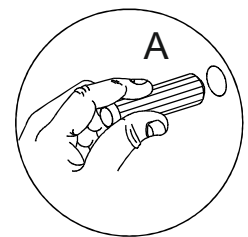
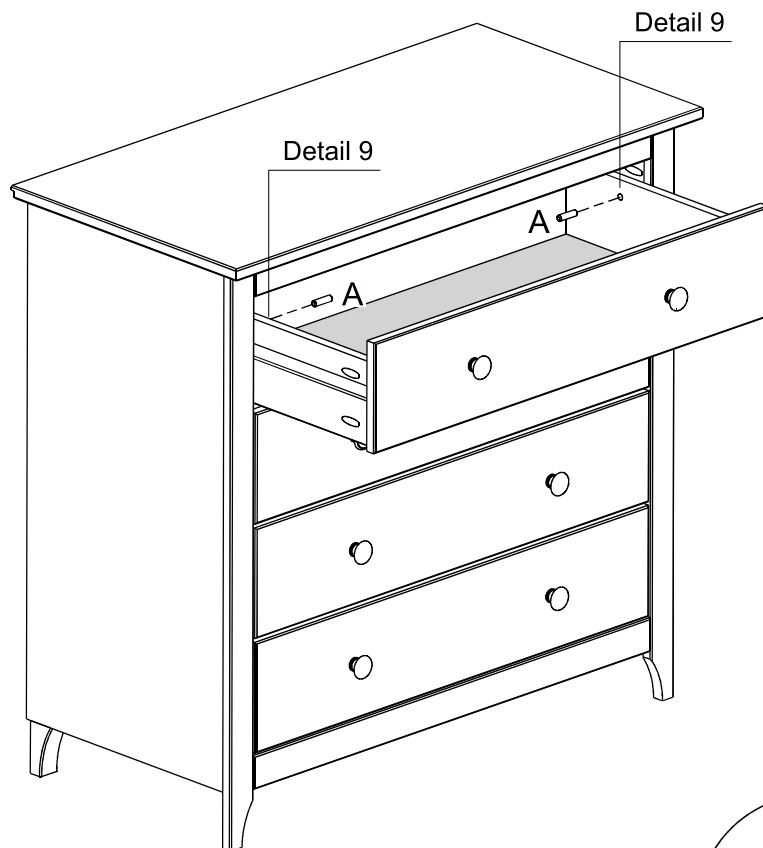
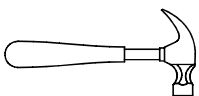

Detail 9



## WARNING

**Serious or fatal injuries can occur from furniture tipping over. To prevent the furniture from tipping over we recommend that it is permanently fixed to the wall.**

Wall fixings are not supplied with this product as different wall materials require different types of fixing devices.

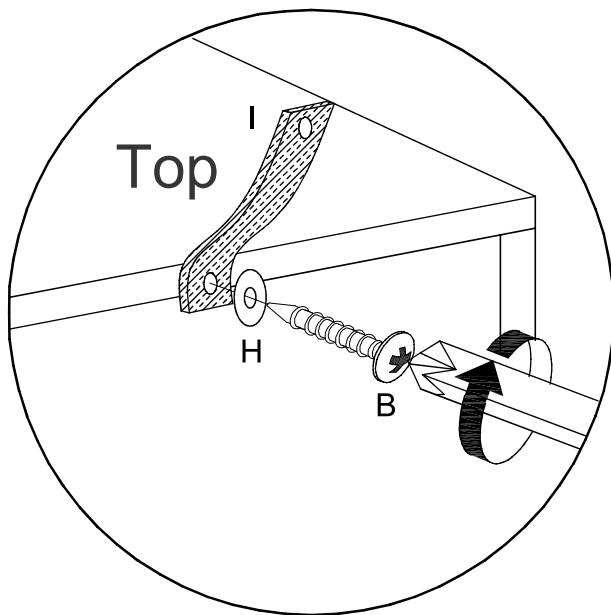
Please make sure you use fixings suitable for the walls in your home.

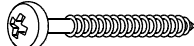

B		1
$\varnothing 3,5 \times 30\text{mm}$		
H		2
Washer		
I		1
Strap		

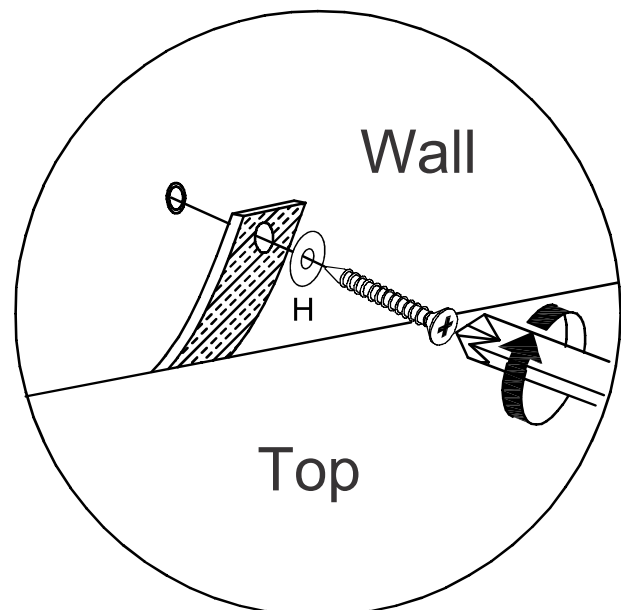
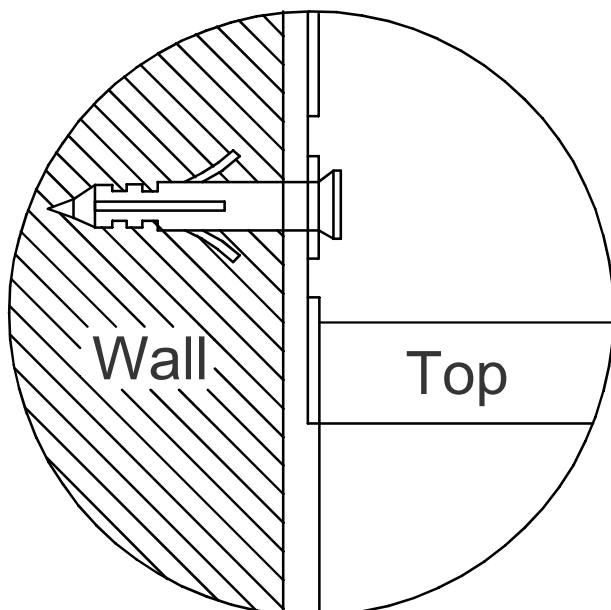

# OSLO 3 DRAWER BEDSIDE ASSEMBLY INSTRUCTIONS

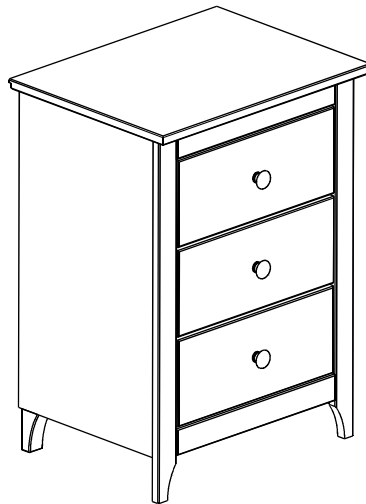

**IMPORTANT**  
**FOR DOMESTIC USE ONLY**  
PLEASE READ BEFORE YOU CONTINUE FURTHER

## CARE AND MAINTENANCE

After unpacking this product please keep the original packaging in case it needs to be returned for any reason.

- Please ensure all fittings and parts are present before commencing with assembly.
- Never drag or push products as this could cause damage to the joints making it inferior.
- We strongly recommend that you keep children away from your work area.
- We recommend that you lay a blanket or sheet on the floor to avoid damage to both your floor and the product.
- Assemble this product as close to its final position as possible.
- Do not place this product next to a radiator or in direct sunlight.
- Do not drag or push items across your high gloss furniture as this may cause the surface to scratch
- Wood is a natural product and may expand if subjected to damp and may shrink or crack if subjected to heat. Therefore it is recommended that room temperature is maintained, with no sudden temperature fluctuations.
- Make sure any spillage is wiped off immediately.
- Do not place hot or chilled items directly on to the surface, use a place mat or marking will occur.
- For general cleaning use a soft cotton or micro fibre cloth, and do not use detergents of any kind.
- From time to time it may be necessary to tighten fittings, regular inspections should be carried out.
- Do not place on a wet or damp floor as staining may occur to your floor.



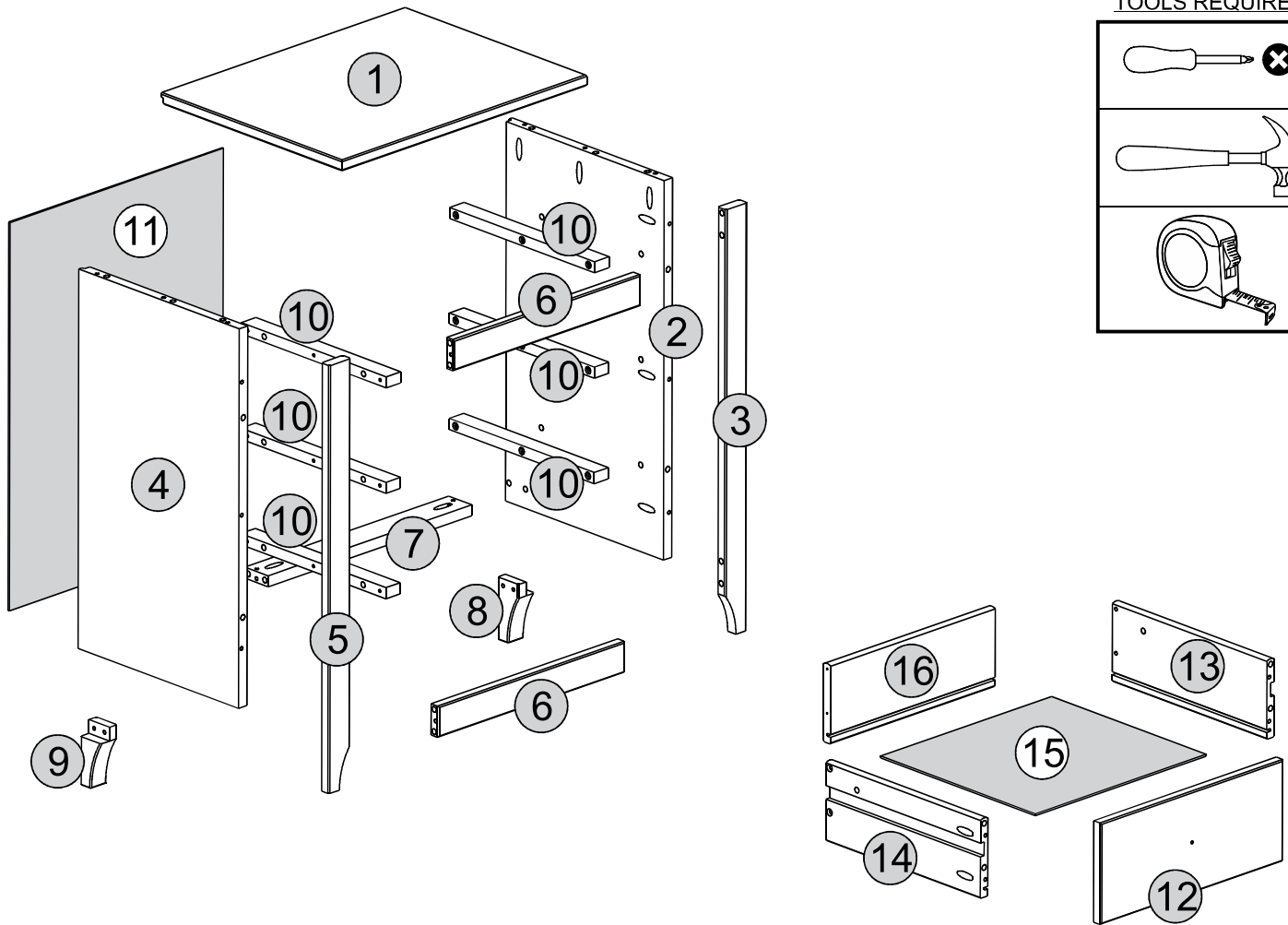
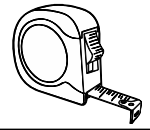
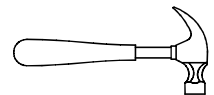
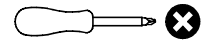



## TOOLS REQUIRED

**PARTS LIST*****Please Note:***

The below parts have all been stamped with the part number to help identify them during assembly.

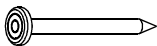
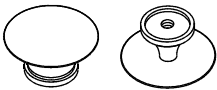
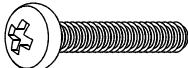
<b>Part Number</b>	<b>Part Code</b>	<b>Part Description</b>	<b>Quantity</b>	<b>Carton</b>
1	S100-103-094-MY1-01	Top Panel	1	1/1
2	S100-103-094-MY1-02	Right Side Panel	1	1/1
3	S100-103-094-MY1-03	Right Front Upright	1	1/1
4	S100-103-094-MY1-04	Left Side Panel	1	1/1
5	S100-103-094-MY1-05	Left Front Upright	1	1/1
6	S100-103-094-MY1-06	Front Crossbeam	2	1/1
7	S100-103-094-MY1-07	Back Crossbeam	1	1/1
8	S100-103-094-MY1-08	Right Back Foot	1	1/1
9	S100-103-094-MY1-09	Left Back Foot	1	1/1
10	S100-103-094-MY1-10	Drawer Runner	6	1/1
11	S100-103-094-MY1-11	Back Panel	1	1/1
12	S100-103-094-MY1-12	Drawer Front	3	1/1
13	S100-103-094-MY1-13	Right Drawer Side	3	1/1
14	S100-103-094-MY1-14	Left Drawer Side	3	1/1
15	S100-103-094-MY1-15	Drawer Bottom	3	1/1
16	S100-103-094-MY1-16	Drawer Back Panel	3	1/1

**FITTINGS LIST**

<p><b>A</b></p>  <p>Dowel +1/2 Ø8,0 x 30mm (52x)</p>	<p><b>B</b></p>  <p>Screw +1/2 Ø3,5 x 30mm (63x)</p>	<p><b>C</b></p>  <p>Flan Head Screw +1/1 Ø4,0 x 35mm (6x)</p>	<p><b>D</b></p>  <p>Nail +1/2 8 x 8 (16x)</p>
<p><b>E</b></p>  <p>Metal Knob (3x)</p>	<p><b>F</b></p>  <p>Screw +1/1 ØM4 x 22mm (3x)</p>	<p><b>H</b></p>  <p>Washer (2x)</p>	<p><b>I</b></p>  <p>Strap (1x)</p>
<p><b>J</b></p>  <p>Glue (1x)</p>			

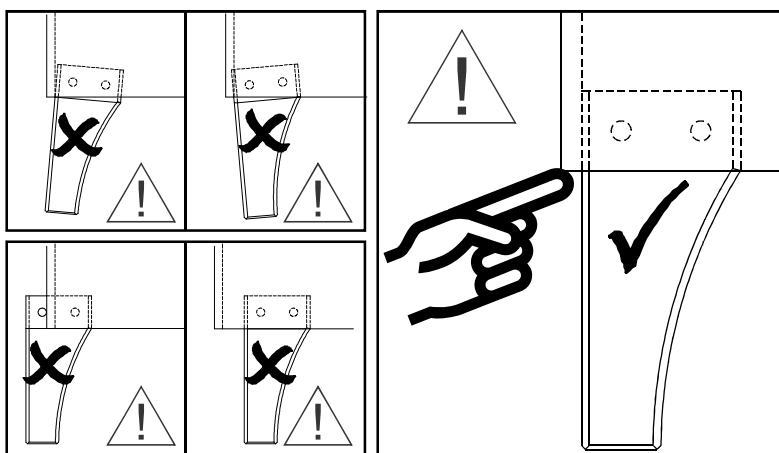

**PLEASE USE THE ABOVE EXAMPLE TO ASSEMBLE THE FEET ON STEP 2.**

# STEP 1

## PARTS REQUIRED

2 - RIGHT SIDE PANEL x1

4 - LEFT SIDE PANEL x1

## HARDWARE REQUIRED

A  10  
Ø8,0 x 30mm

J  01  
Glue

## TOOLS REQUIRED

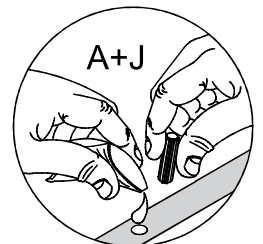
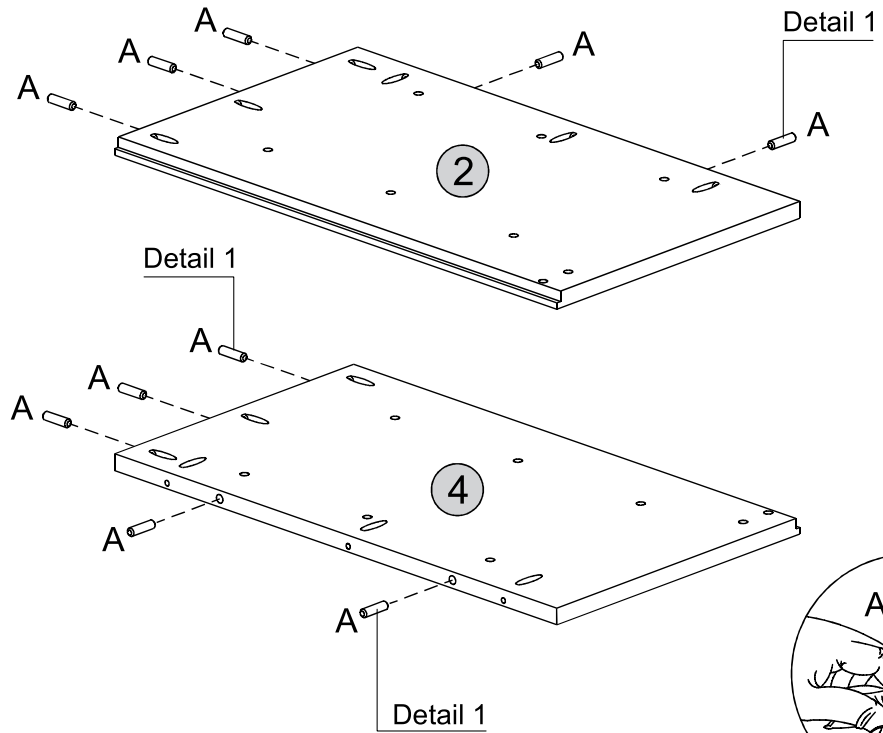
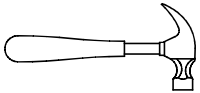

Detail 1

# STEP 2

## PARTS REQUIRED

2 - RIGHT SIDE PANEL x1

4 - LEFT SIDE PANEL x1

8 - RIGHT BACK FOOT x1

4 - LEFT BACK FOOT x1

## HARDWARE REQUIRED

C  04  
Ø4,0 x 35mm

## TOOLS REQUIRED

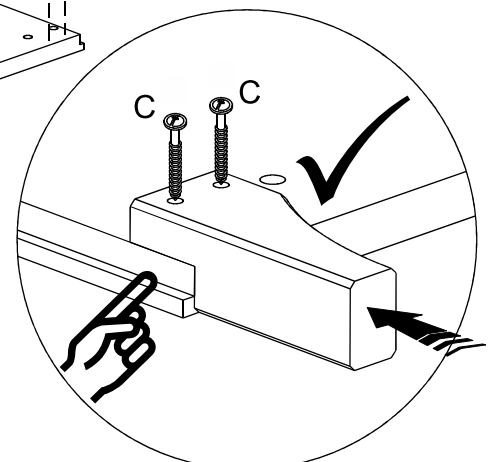
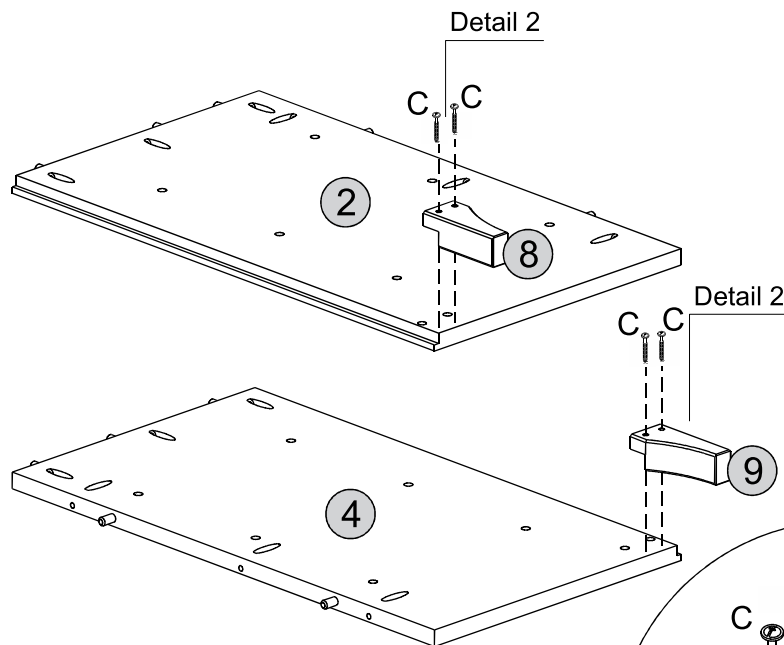
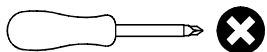

PLEASE REFER TO PAGE 2 FOR FOOT ASSEMBLY. Detail 2

# STEP 3

## PARTS REQUIRED

3 - RIGHT FRONT UPRIGHT x1

5 - LEFT FRONT UPRIGHT x1

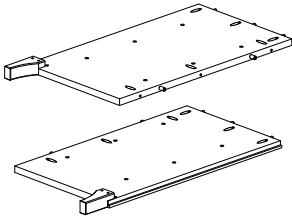

## HARDWARE REQUIRED

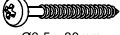
B  06  
Ø3,5 x 30mm

J  01  
Glue

## TOOLS REQUIRED

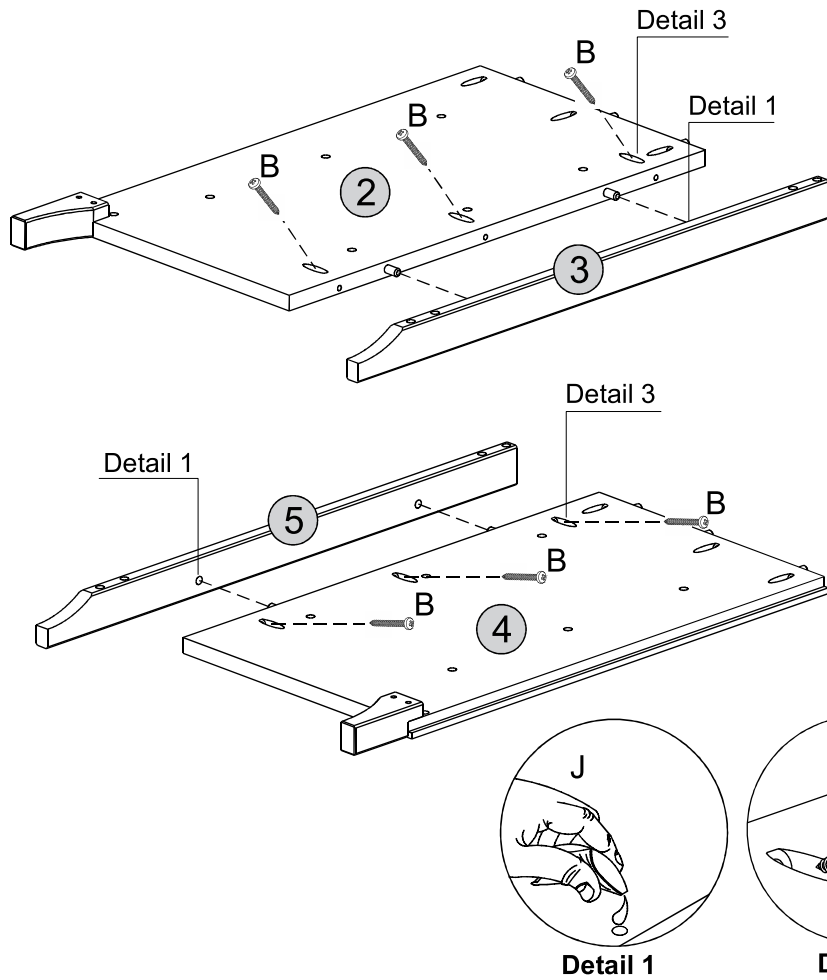
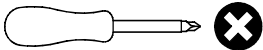

# STEP 4

## PARTS REQUIRED

6 - FRONT CROSSBEAM x2

7 - BACK CROSSBEAM x1

## HARDWARE REQUIRED

A  12  
Ø8,0 x 30mm

J  01  
Glue

## TOOLS REQUIRED

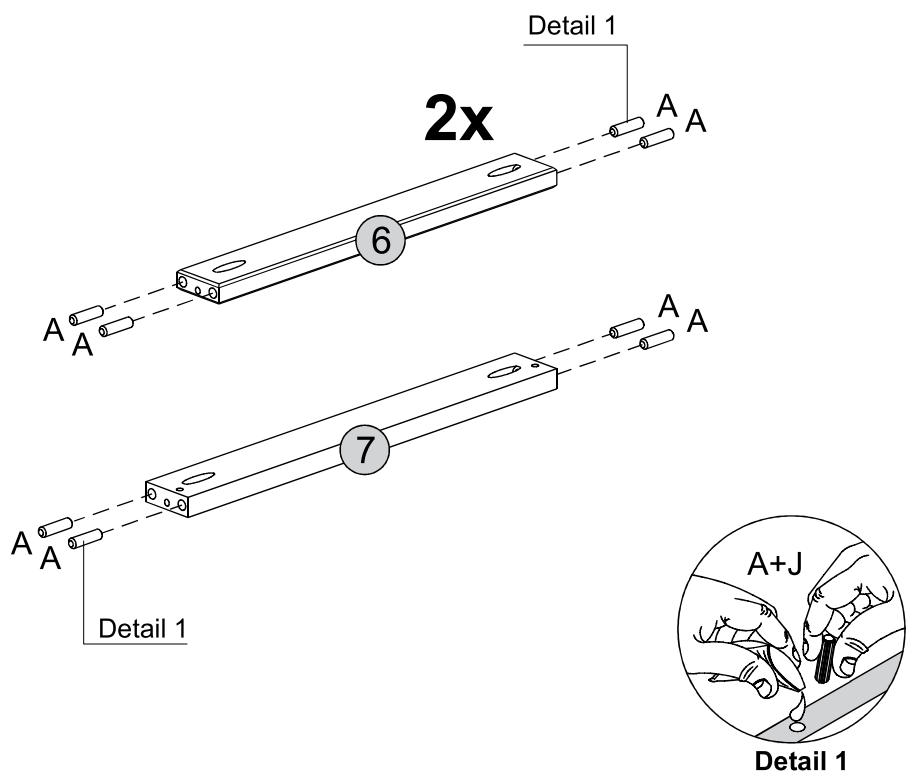
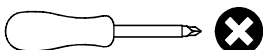



# STEP 5

## PARTS REQUIRED

6 - FRONT CROSSBEAM x2

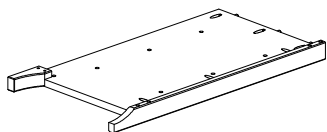

## HARDWARE REQUIRED

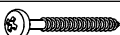
B  02  
Ø3,5 x 30mm

J  01  
Glue

## TOOLS REQUIRED

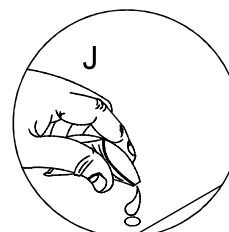
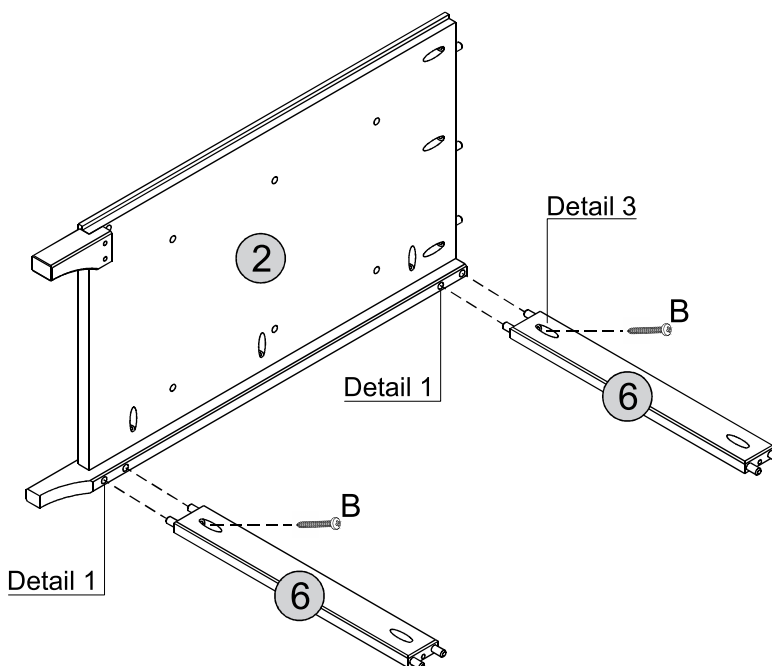
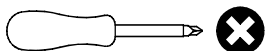

Detail 1

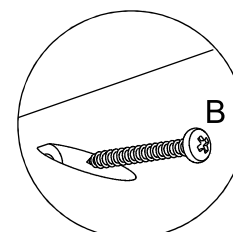

Detail 3

# STEP 6

## PARTS REQUIRED

7 - BACK CROSSBEAM x1

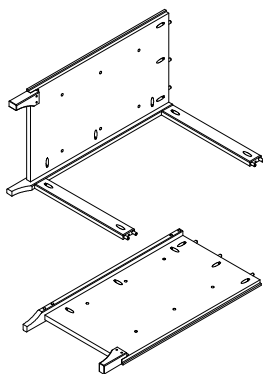

## HARDWARE REQUIRED

B  04  
Ø3,5 x 30mm

J  01  
Glue

## TOOLS REQUIRED

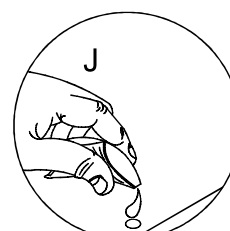
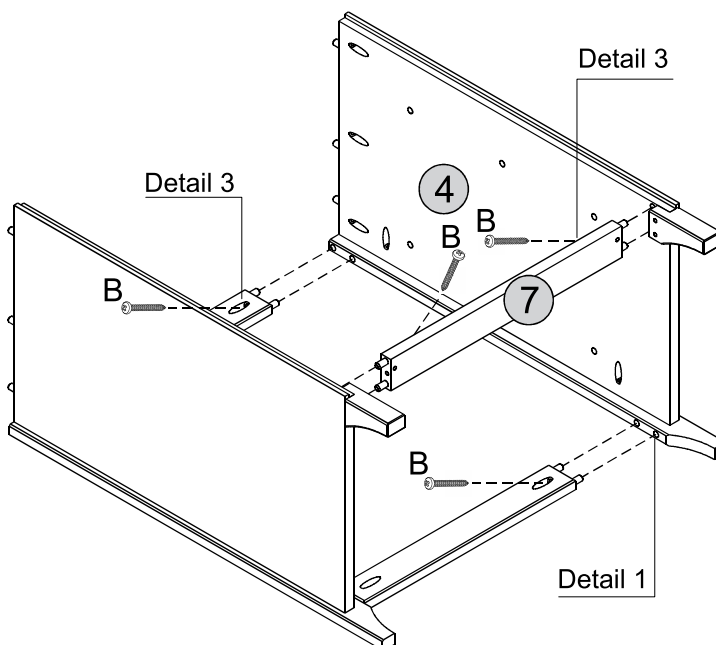
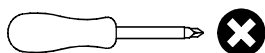

Detail 1

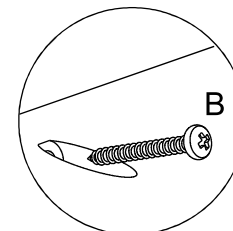

Detail 3

# STEP 7

## PARTS REQUIRED

1 - TOP PANEL x1

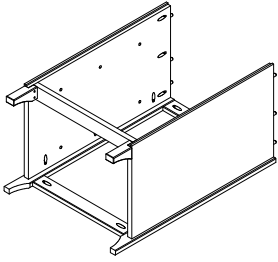

## HARDWARE REQUIRED

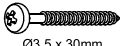
**B**  06  
Ø3,5 x 30mm

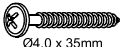
**C**  02  
Ø4,0 x 35mm

**J**  01  
Glue

## TOOLS REQUIRED

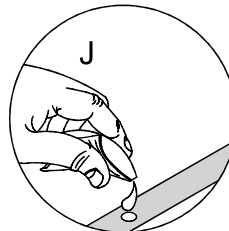
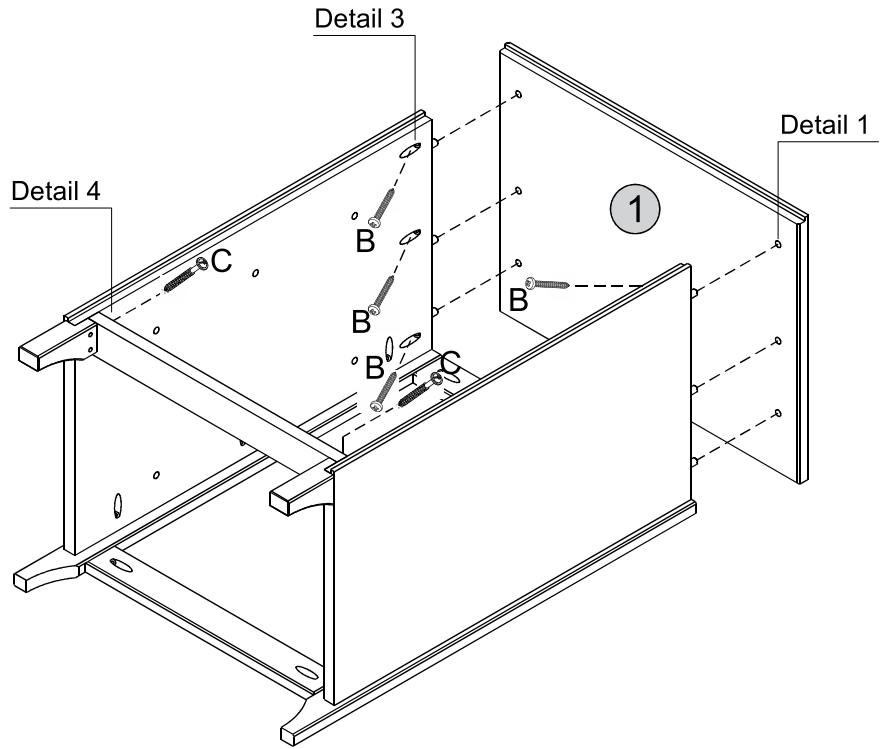
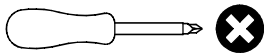

Detail 1

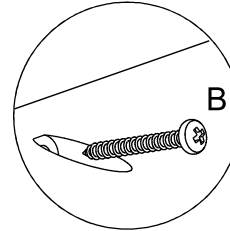

Detail 3

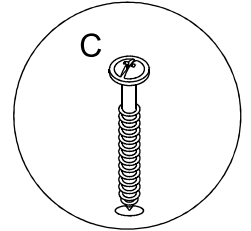

Detail 4

# STEP 8

## PARTS REQUIRED

10 - DRAWER RUNNER x6

## HARDWARE REQUIRED

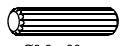
**A**  12  
Ø8,0 x 30mm

**J**  01  
Glue

## TOOLS REQUIRED

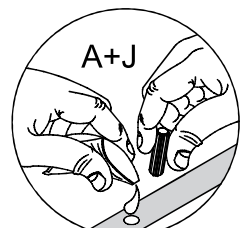
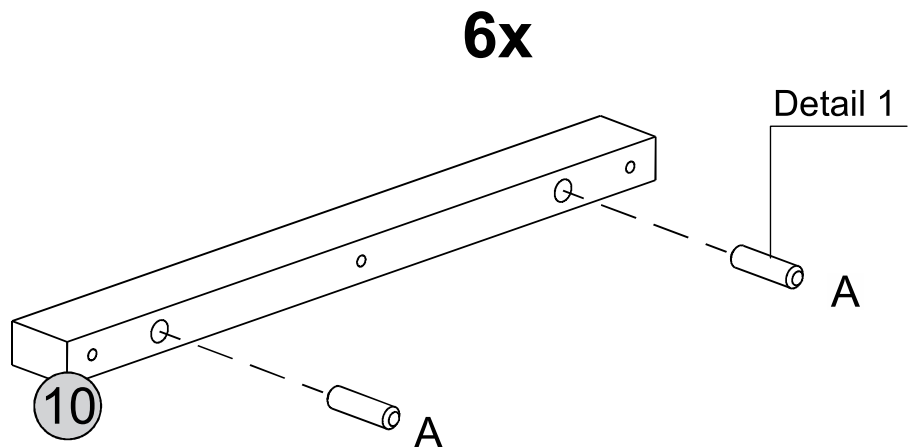
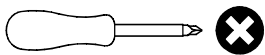

Detail 1

# STEP 9

## PARTS REQUIRED

10 - DRAWER RUNNER x6

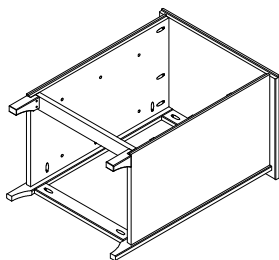

## HARDWARE REQUIRED

B  18  
Ø3,5 x 30mm

J  01  
Glue

## TOOLS REQUIRED

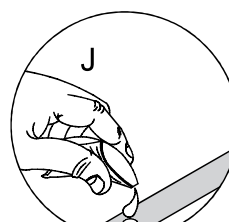
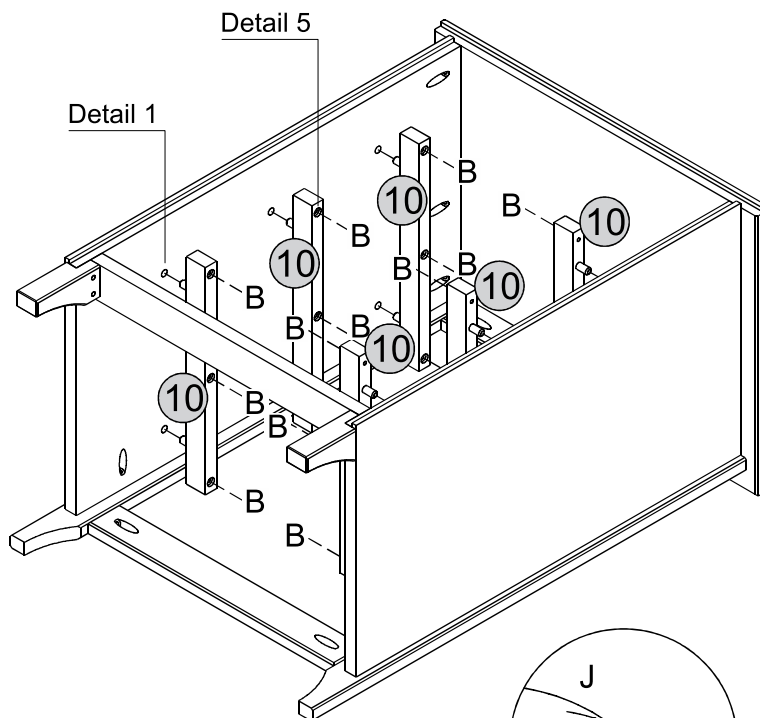
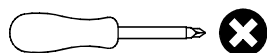

Detail 1

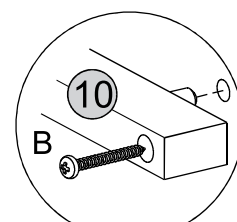

Detail 5

# STEP 10

## PARTS REQUIRED

11 - BACK PANEL x2

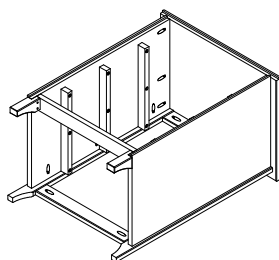

## HARDWARE REQUIRED

D  16  
8 x 8

## TOOLS REQUIRED

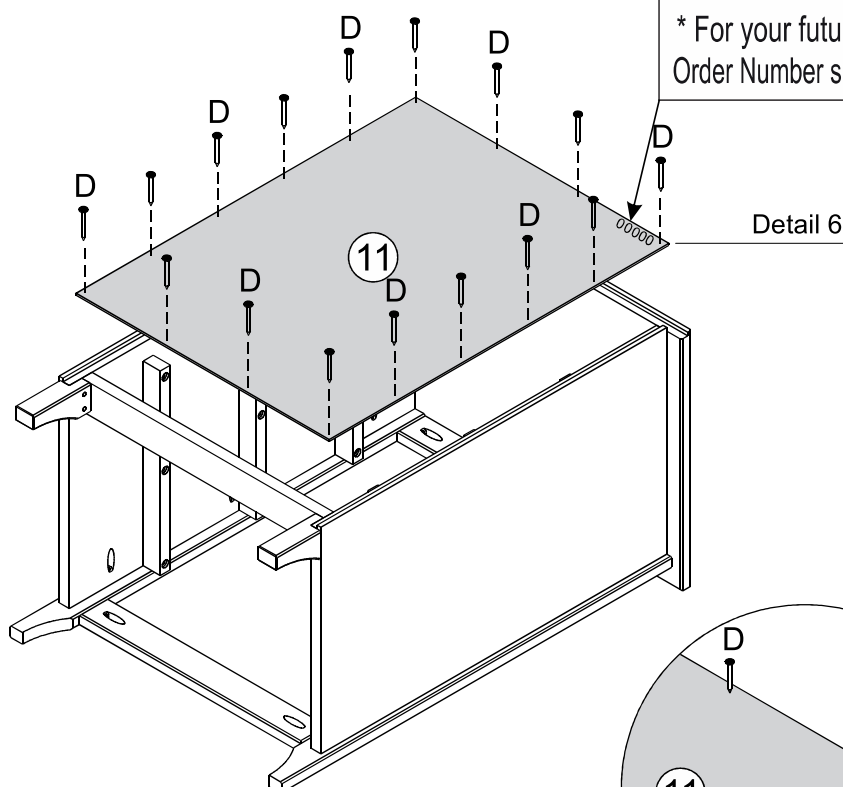
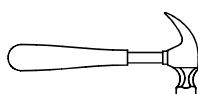

\* For your future reference  
Order Number should be here

Detail 6

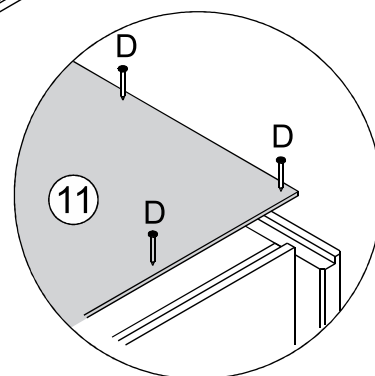

Detail 6

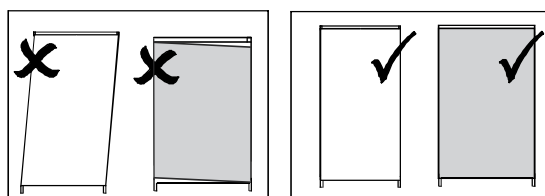

# STEP 11

PARTS REQUIRED

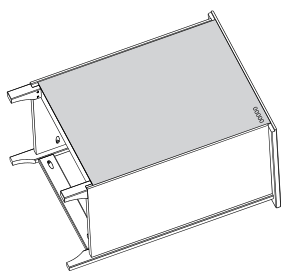

HARDWARE REQUIRED

TOOLS REQUIRED

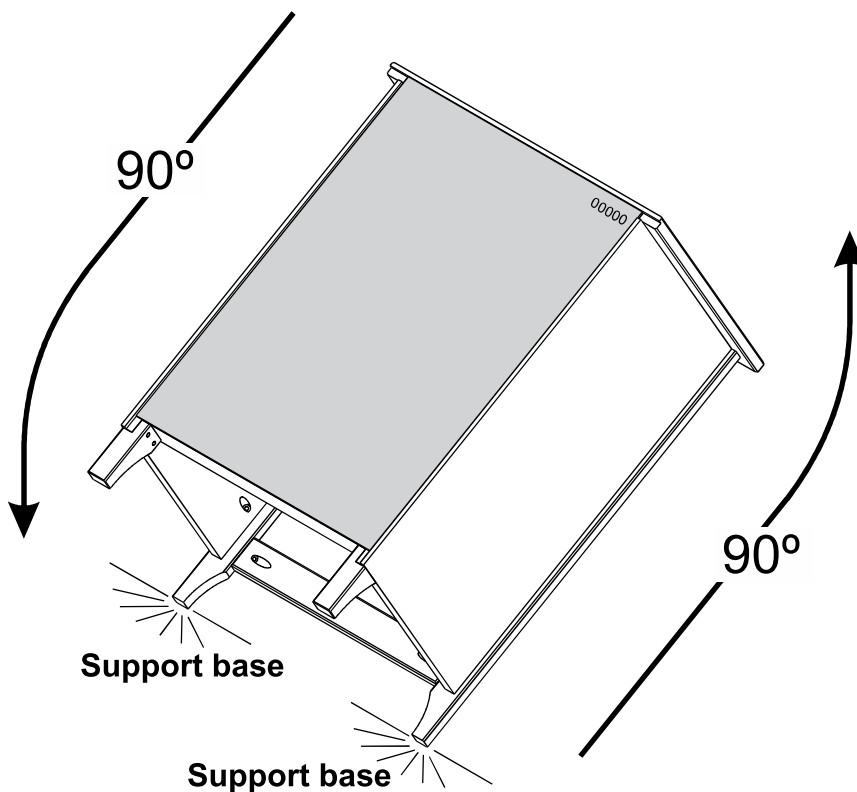

# STEP 12

PARTS REQUIRED

13 - RIGHT DRAWER SIDE x1

14 - LEFT DRAWER SIDE x1

HARDWARE REQUIRED

A  12  
Ø8.0 x 30mm

J  01  
Glue

TOOLS REQUIRED

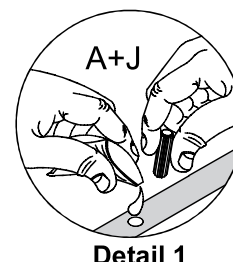
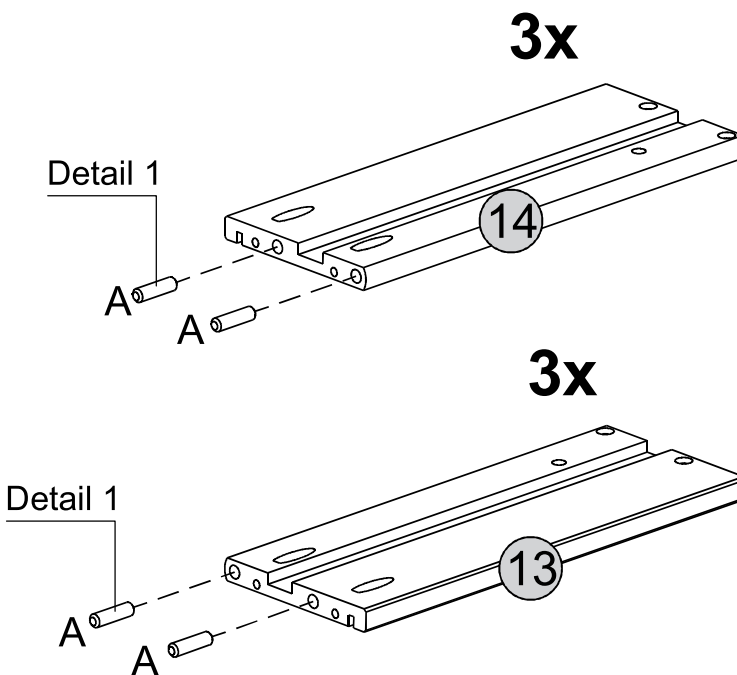
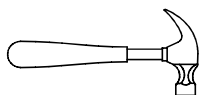

# STEP 13

## PARTS REQUIRED

12 - DRAWER FRONT x3

13 - RIGHT DRAWER SIDE x3

14 - LEFT DRAWER SIDE x3

## HARDWARE REQUIRED

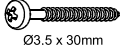
**B**  12  
Ø3,5 x 30mm

**J**  01  
Glue

## TOOLS REQUIRED

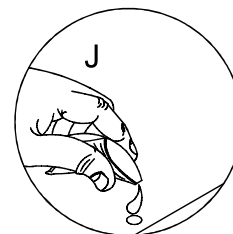
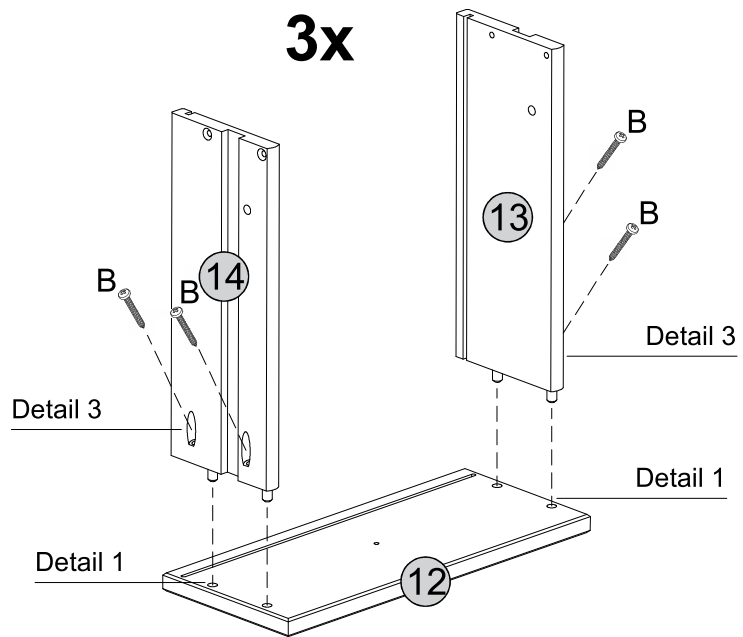
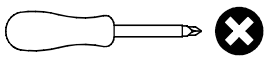

Detail 1

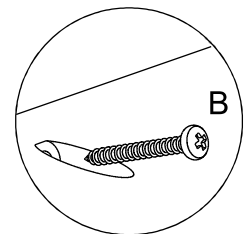

Detail 3

# STEP 14

## PARTS REQUIRED

15 - DRAWER BOTTOM x3

16 - DRAWER BACK PANEL x3

## HARDWARE REQUIRED

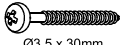
**B**  12  
Ø3,5 x 30mm

## TOOLS REQUIRED

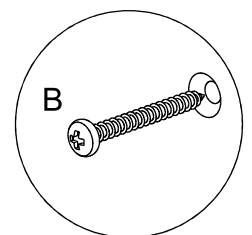
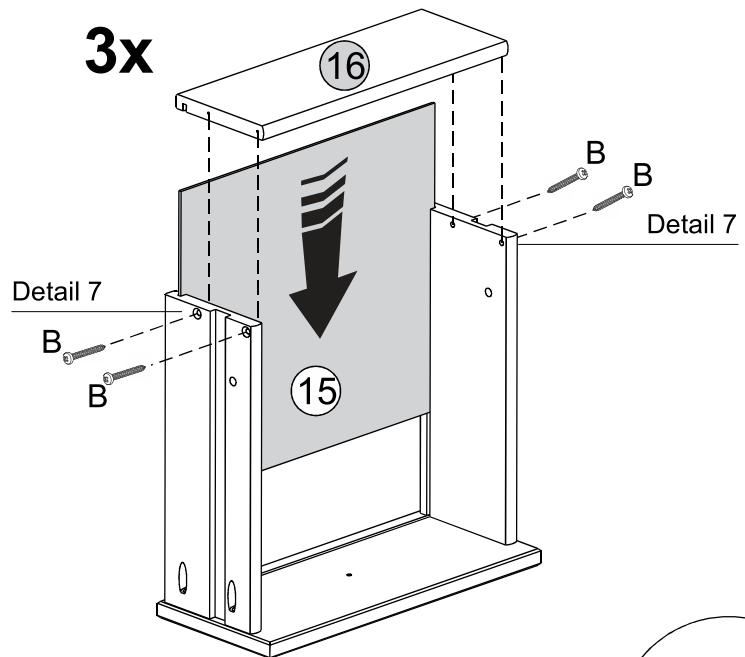
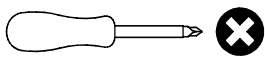

Detail 7

# STEP 15

PARTS REQUIRED

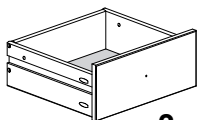

3x

HARDWARE REQUIRED

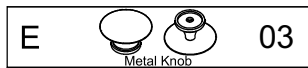

TOOLS REQUIRED

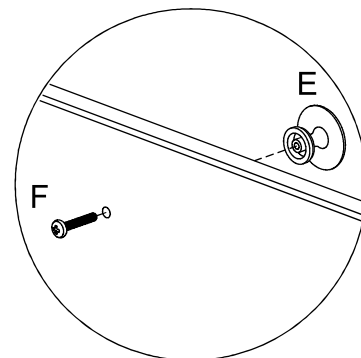
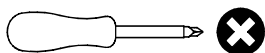

Detail 8

3x

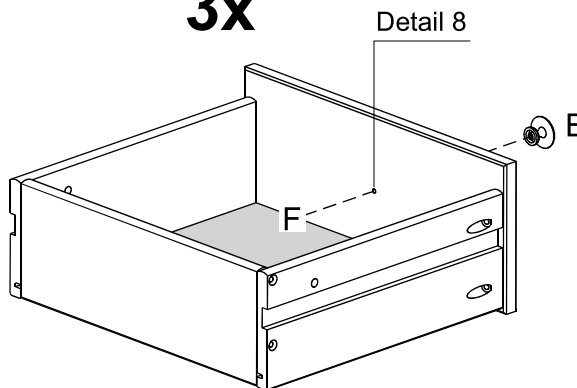

# STEP 16

PARTS REQUIRED

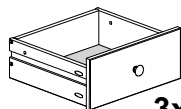
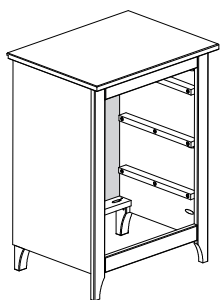

3x

HARDWARE REQUIRED

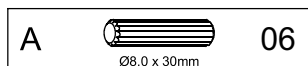

TOOLS REQUIRED

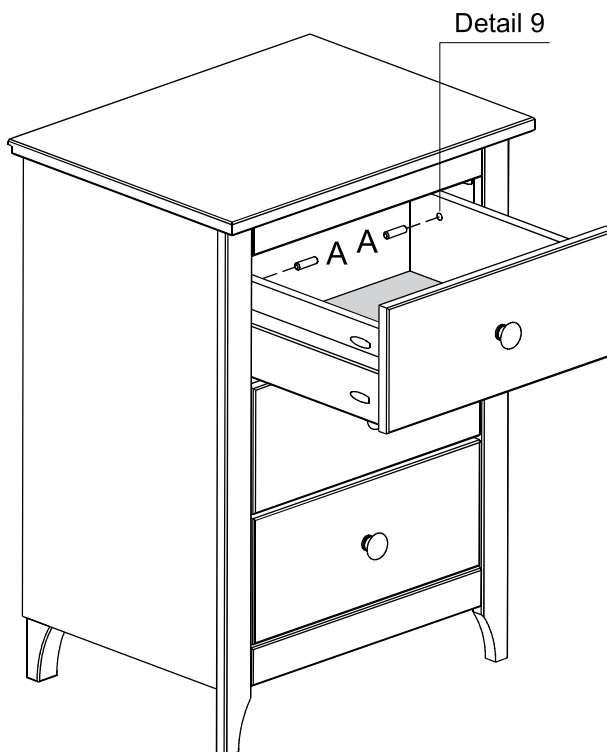
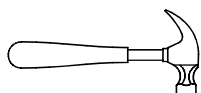

Detail 9

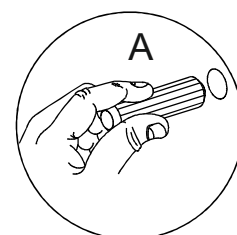

Detail 9



## WARNING

**Serious or fatal injuries can occur from furniture tipping over. To prevent the furniture from tipping over we recommend that it is permanently fixed to the wall.**

Wall fixings are not supplied with this product as different wall materials require different types of fixing devices.

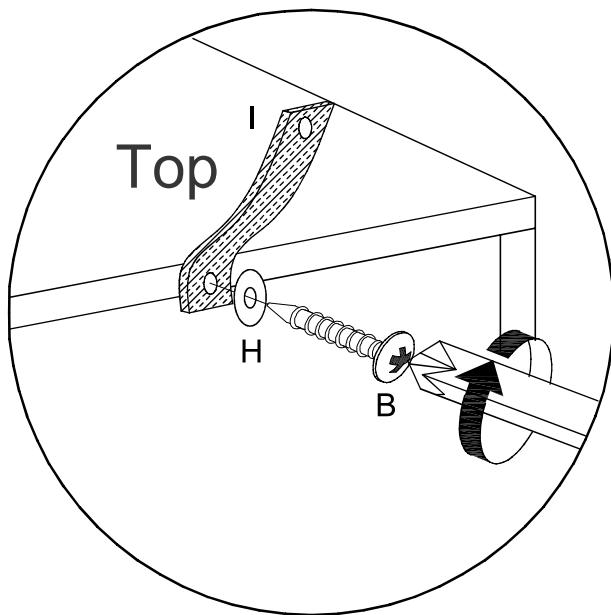
Please make sure you use fixings suitable for the walls in your home.

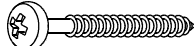

B		1
	$\varnothing 3,5 \times 30\text{mm}$	
H		2
	Washer	
I		1
	Strap	

