

GREY MALVERN 3 DOOR WARDROBE ASSEMBLY INSTRUCTIONS

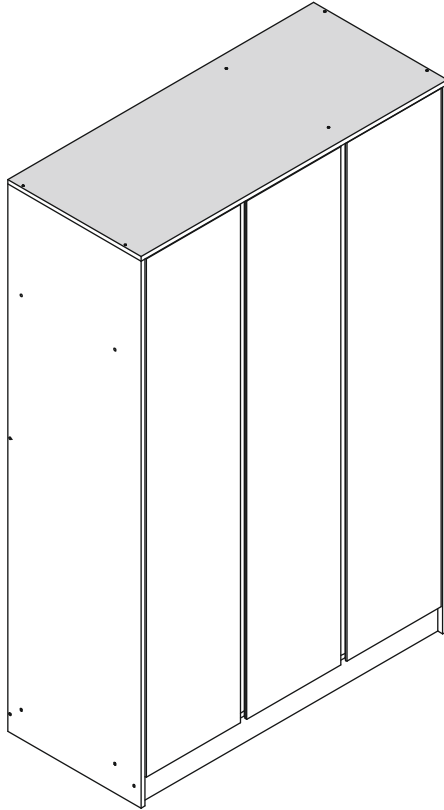

**FOR DOMESTIC USE ONLY
IMPORTANT
PLEASE READ BEFORE YOU CONTINUE FURTHER**

THE PRODUCT YOU HAVE PURCHASED WILL GIVE YOU MANY YEARS OF SERVICE IF YOU FOLLOW THE GUIDELINES FOR ITS SAFE ASSEMBLY AND PERIODIC MAINTENANCE AND CLEANING.

ASSEMBLE ON A SOFT CLEAN SURFACE.

DO NOT USE ANY TOOLS OTHER THAN THOSE SHOWN.

ANY SPANNERS OR ALLEN KEYS REQUIRED ARE INCLUDED WITH THE FITTING KIT.

DO NOT FOR ANY REASON USE A POWER TOOL TO ASSEMBLE THIS PRODUCT. ITS USE WILL INVALIDATE ANY CLAIM YOU MAY HAVE AND COULD MAKE THIS PRODUCT UNSAFE.

DEPENDING ON THE AMOUNT OF USE THIS PRODUCT RECEIVES, IT MAY BE NECESSARY TO TIGHTEN UP THE FIXINGS FROM TIME TO TIME. THIS IS COMPLETELY NORMAL FOR ANY FLAT PACK FURNITURE. DO NOT OVERTIGHTEN FIXINGS.

FOR CLEANING, YOU MAY USE A DAMP CLOTH (NOT WET). DO NOT USE POLISH, DETERGENT OR CHEMICAL CLEANERS.



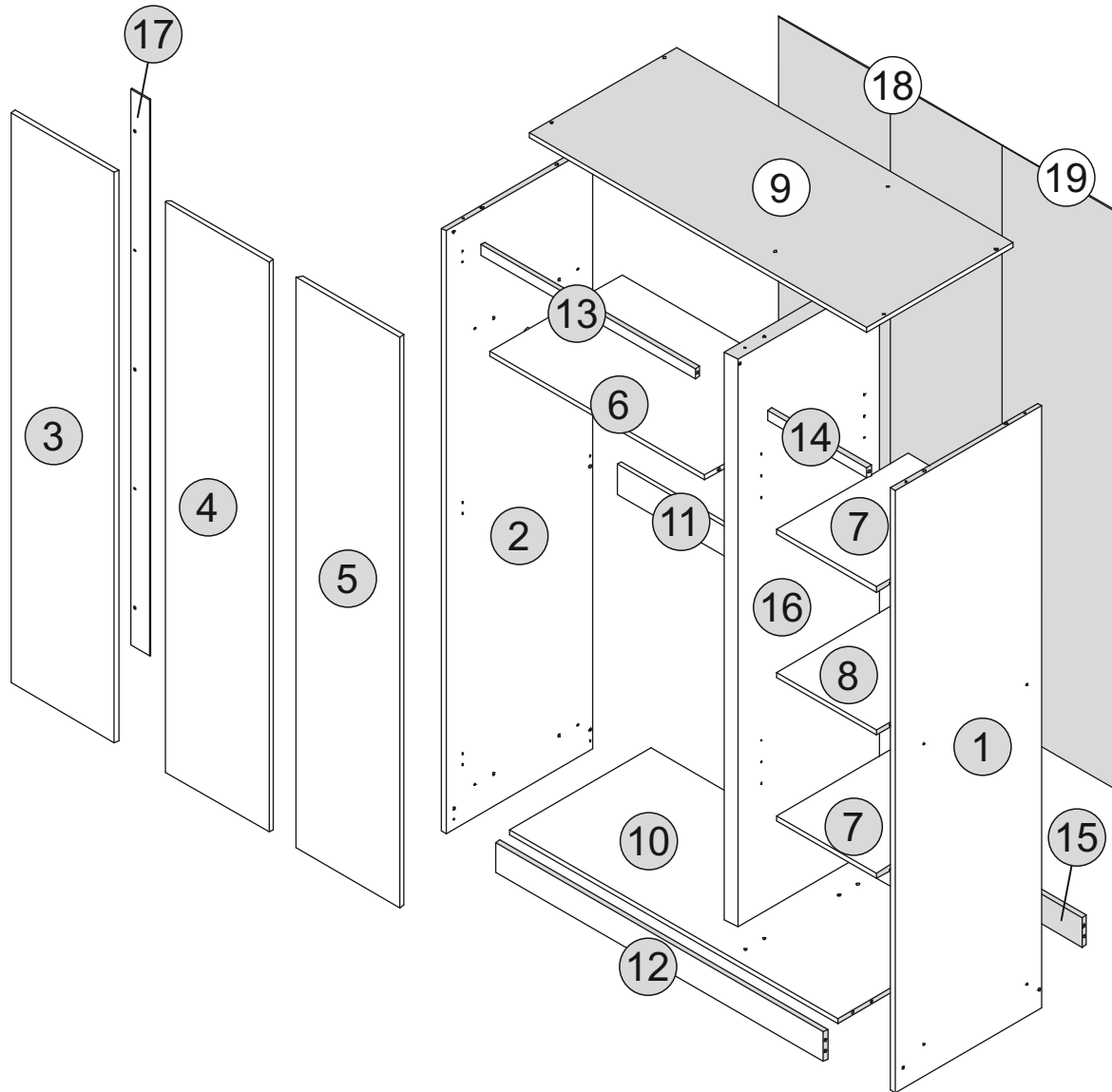











THIS SURFACE OF THIS ITEM IS NOT HEAT RESISTANT. ALWAYS USE A PLACE MAT UNDER HOT OR COLD ITEMS TO PREVENT MARKING.



PART LIST

Part Number	Part Code	Part Description	Quantity	Carton
1	S100-101-174-ZF1-01	Right Side Panel	1	1/3
2	S100-101-174-ZF1-02	Left Side Panel	1	1/3
3	S100-101-174-ZF1-03	Left Door	1	2/3
4	S100-101-174-ZF1-04	Centre Door	1	2/3
5	S100-101-174-ZF1-05	Right Door	1	2/3
6	S100-101-174-ZF1-06	Large Shelf Panel	1	3/3
7	S100-101-174-ZF1-07	Small Shelf Panel	2	3/3
8	S100-101-174-ZF1-08	Shelf Panel	1	1/3
9	S100-101-174-ZF1-09	Top Panel	1	1/3
10	S100-101-174-ZF1-10	Bottom Panel	1	3/3
11	S100-101-174-ZF1-11	Back Support Panel	1	2/3
12	S100-101-174-ZF1-12	Front Crossbar	1	2/3
13	S100-101-174-ZF1-13	Large Support Panel	1	3/3
14	S100-101-174-ZF1-14	Small Support Panel	1	1/3
15	S100-101-174-ZF1-15	Back Crossbar	1	2/3
16	S100-101-174-ZF1-16	Centre Panel	1	2/3
17	S100-101-174-ZF1-17	Door Support	1	1/3
18	S100-101-174-ZF1-18	Large Back Panel	1	1/3
19	S100-101-174-ZF1-19	Small Back Panel	1	1/3

HARDWARE LIST

No	Part Name		Qty	Carton
A	M8x30mm Wooden Dowel		x30	2
B	M4x45mm Screw		x21	2
C	M3.5x16mm Screw		x51	2
D	PVC L-Bracket		x4	2
E	Screw Cover <small>(Sticker 12mm)</small>		x13	2
F	Plastic Foot		x6	2
G	6/8" Nail		x94	2
H	Hanging Rail (746mm)		x1	2
I	Wall Fixing <small>(4x20mm=1pc)</small>		x1	2
J	End Hinges <small>(M11)- Big</small>		x6	2
K	Centre Hinges <small>(M03 - 4 hole)</small>		x3	2
L	Minifix Cam Bolt <small>(8032t)</small>		x5	2
M	Minifix Cam Nut <small>(1512)</small>		x5	2
N	Shelf Support <small>(AC45-W)</small>		x8	2

TIPS FOR FITTINGS CAM-LOCKS

WHEN FITTING CAM NUT, ENSURE STARTING POSITION IS CORRECT BEFORE YOU INSERT CONNECTING CAM BOLT TURN CLOCKWISE UNTIL SECURE

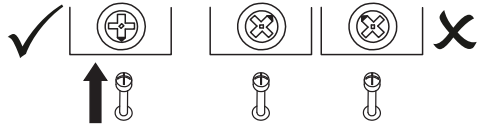

CORRECT **WRONG**

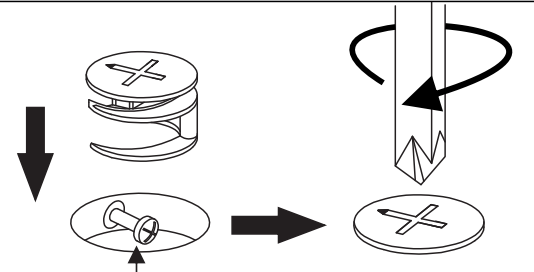

Cam bolt head needs to be in centre

CAMBOLT

Tighten until shoulder in flush with panel. Do not overtighten or undertighten (see example below)

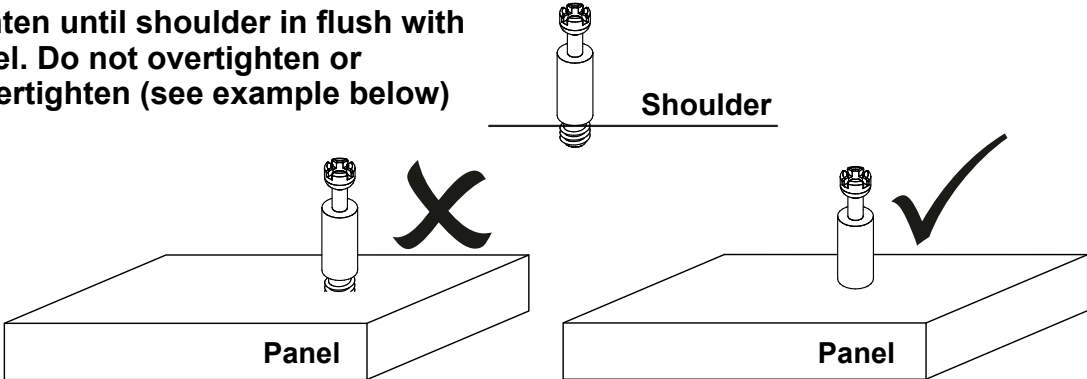

Panel **Panel**



Shoulder

STEP 1

PARTS REQUIRED

9 - TOP PANEL	x1
10 - BOTTOM PANEL	x1
13 - LARGE SUPPORT PANEL	x1
14 - SMALL SUPPORT PANEL	x1
15 - BACK CROSSBAR	x1

HARDWARE REQUIRED

A		10
C	 3.5x16mm	04
D		04

TOOLS REQUIRED

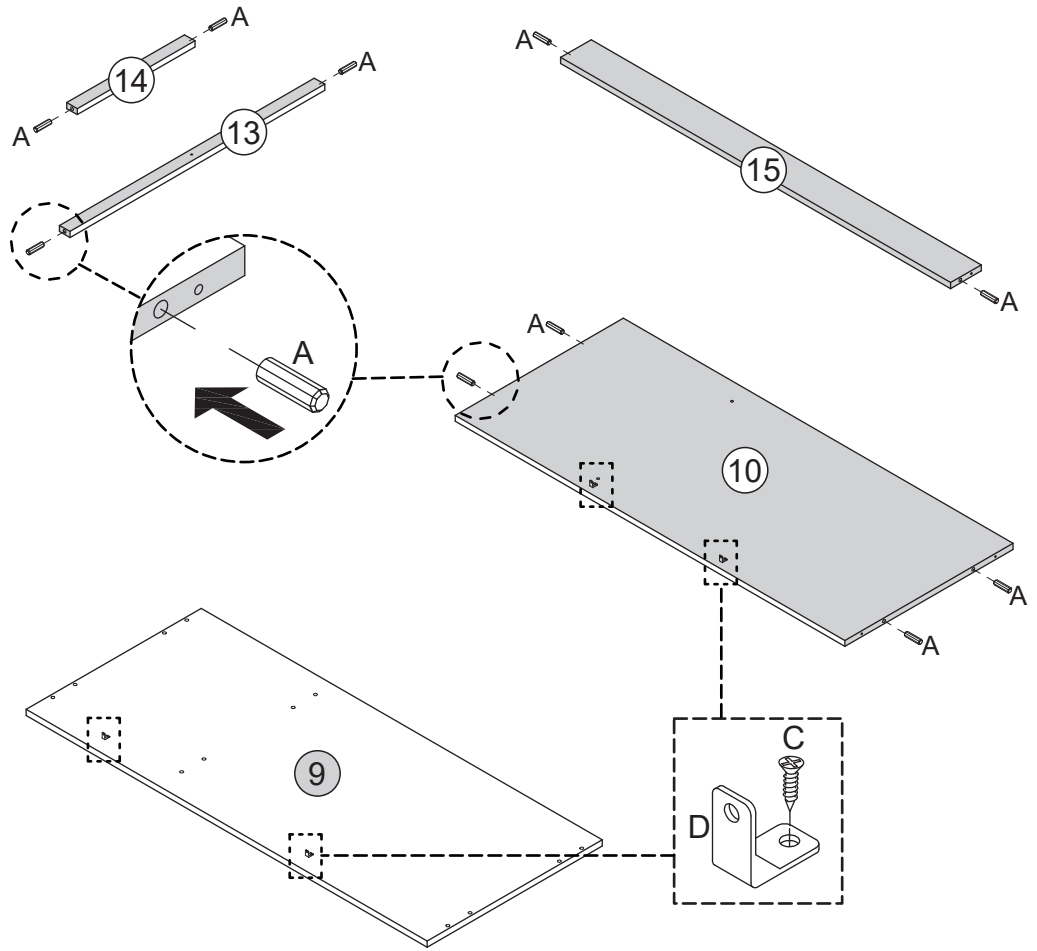
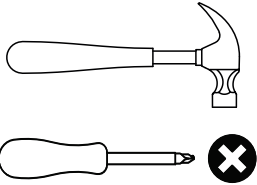



STEP 2

PARTS REQUIRED

6 - LARGE SHELF PANEL	x1
8 - SHELF PANEL	x1
11 - BACK SUPPORT PANEL	x1

HARDWARE REQUIRED

A		10
M		05

TOOLS REQUIRED

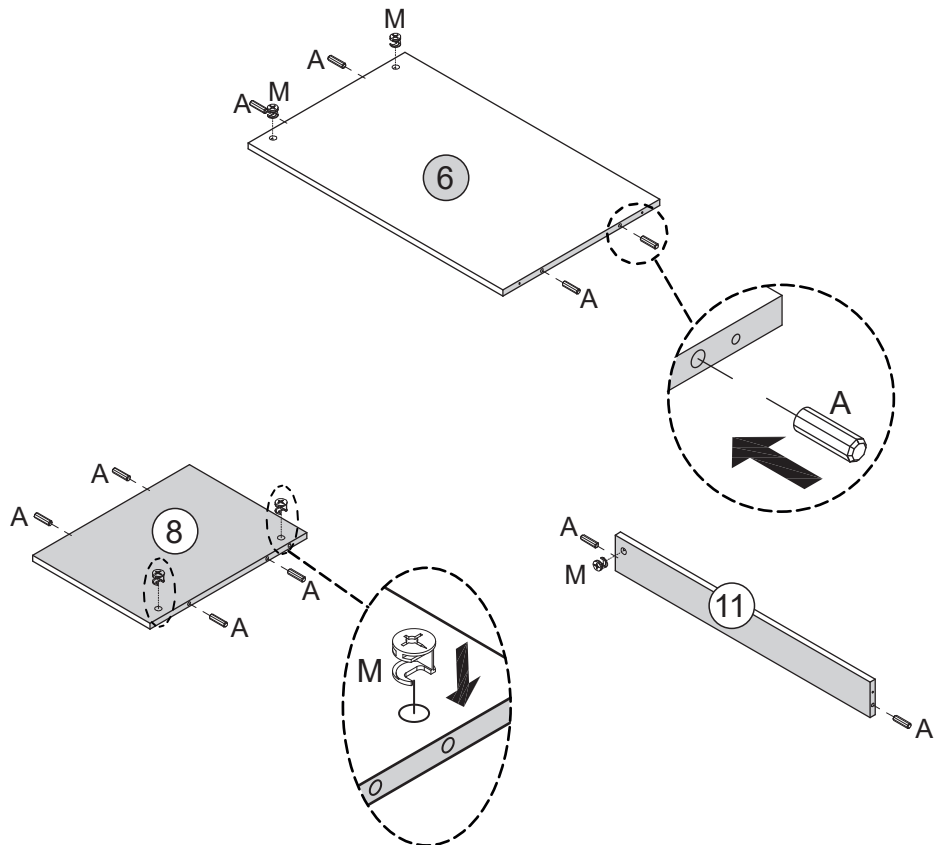
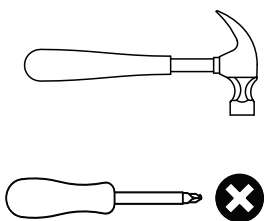



STEP 3

PARTS REQUIRED

1 - RIGHT SIDE PANEL	x1
2 - LEFT SIDE PANEL	x1
12 - FRONT CROSSBAR	x1
16 - CENTRE PANEL	x1

HARDWARE REQUIRED

A		10
F		06
N		08

TOOLS REQUIRED

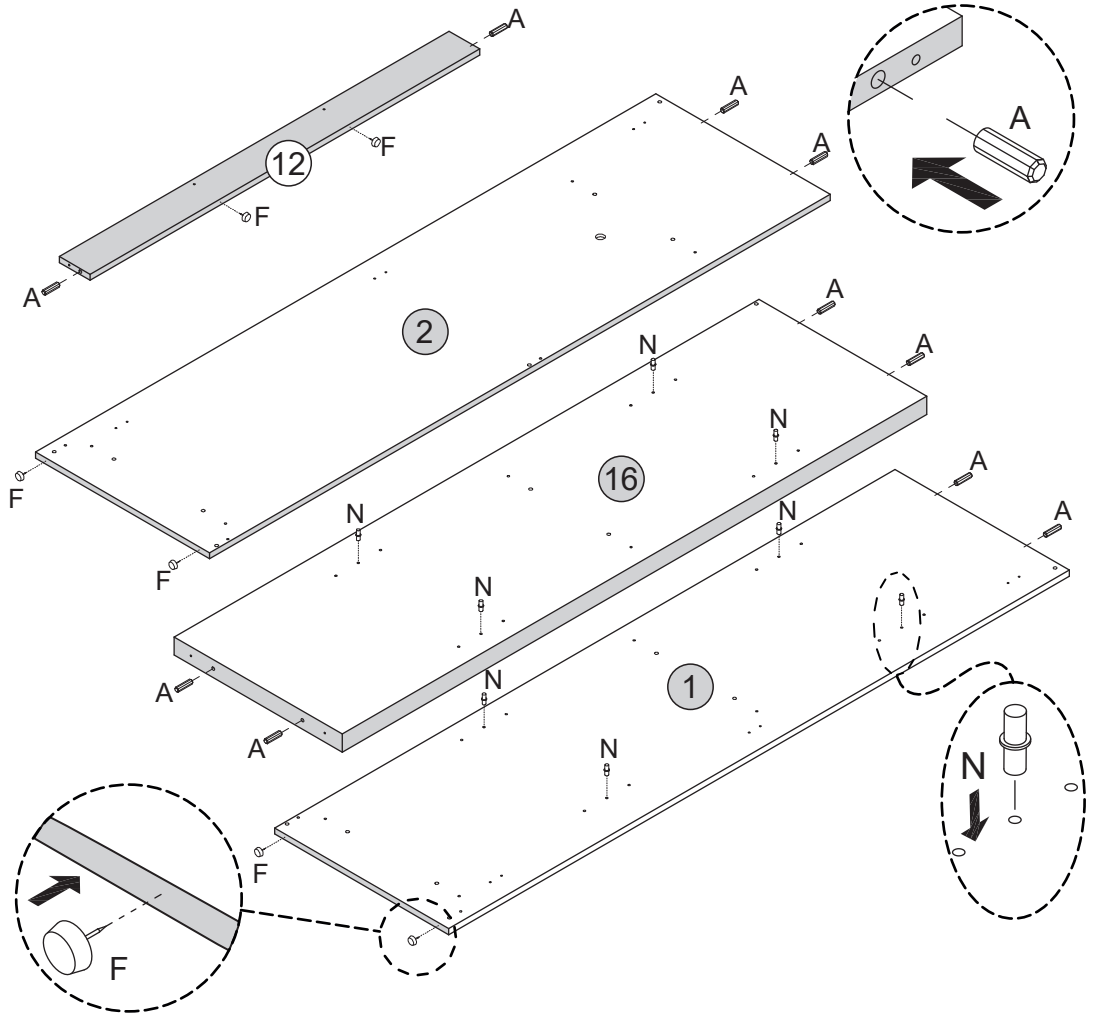
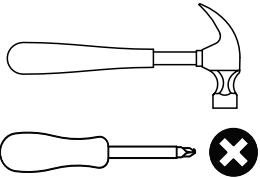

STEP 4

PARTS REQUIRED

16 - CENTRE PANEL	x1
-------------------	----

HARDWARE REQUIRED

L		05
---	---	----

TOOLS REQUIRED

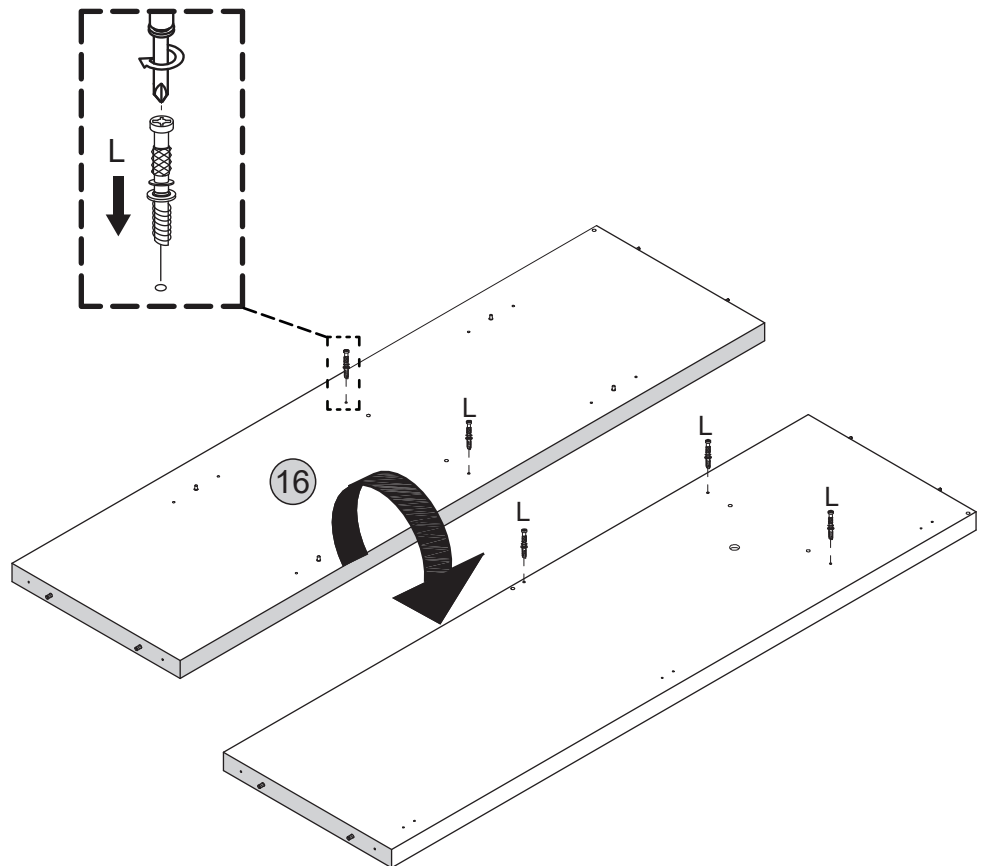
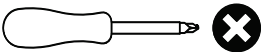

STEP 5

PARTS REQUIRED

3 - LEFT DOOR x1

4 - CENTRE DOOR x1

5 - RIGHT DOOR x1

17 - DOOR SUPPORT x1

HARDWARE REQUIRED

C  23
3.5x16mm

J  06

K  03

TOOLS REQUIRED

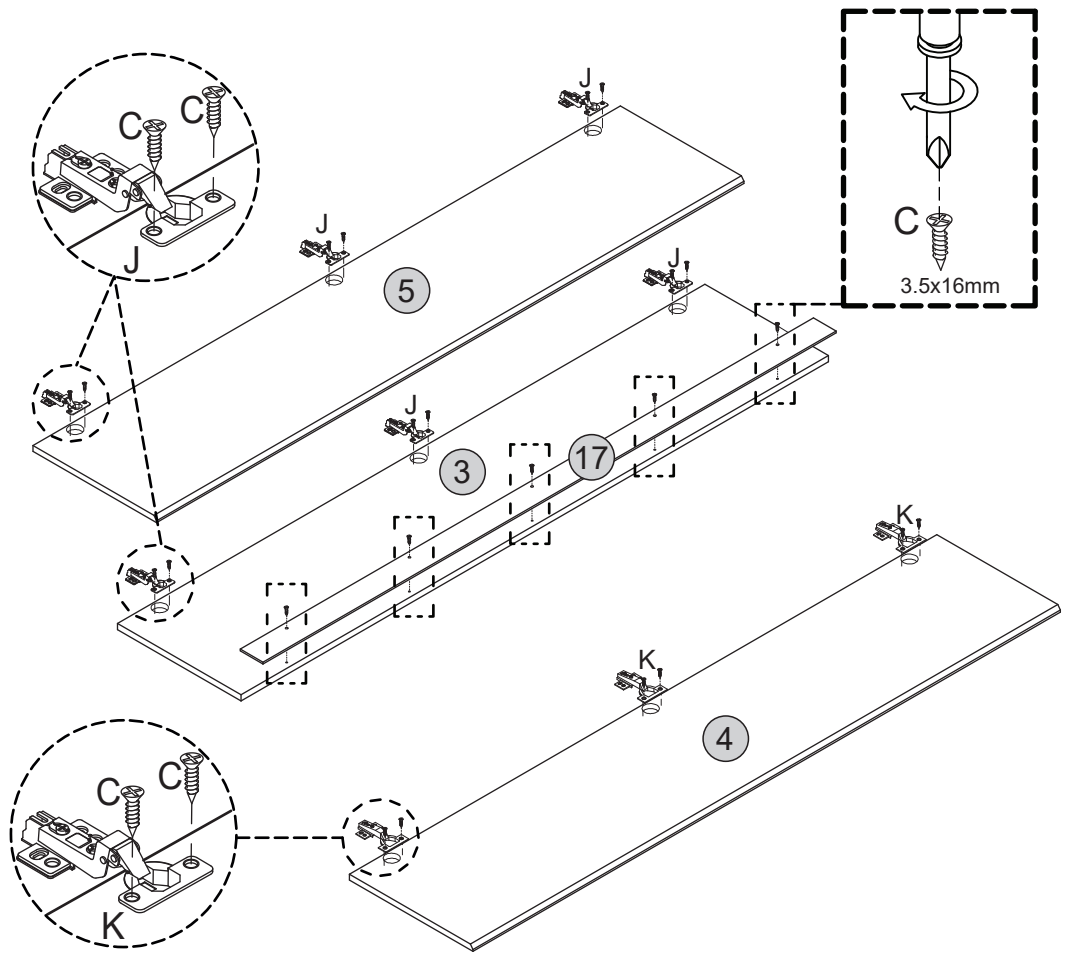
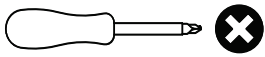

STEP 6

PARTS REQUIRED

10 - BOTTOM PANEL x1

16 - CENTRE PANEL x1

HARDWARE REQUIRED

B  02
4x45mm

TOOLS REQUIRED

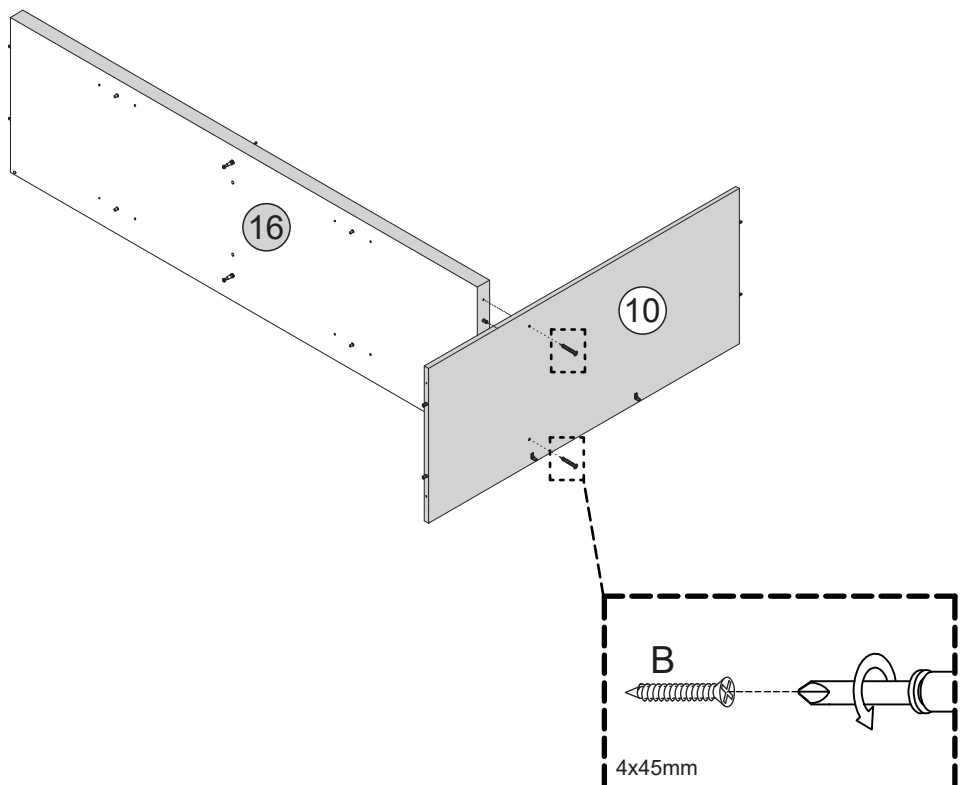
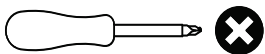

STEP 7

PARTS REQUIRED

1 - RIGHT SIDE PANEL x1

8 - SHELF PANEL x1

14 - SMALL SUPPORT PANEL x1

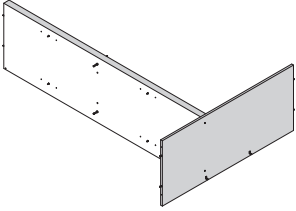

HARDWARE REQUIRED

B  04

E  04

TOOLS REQUIRED

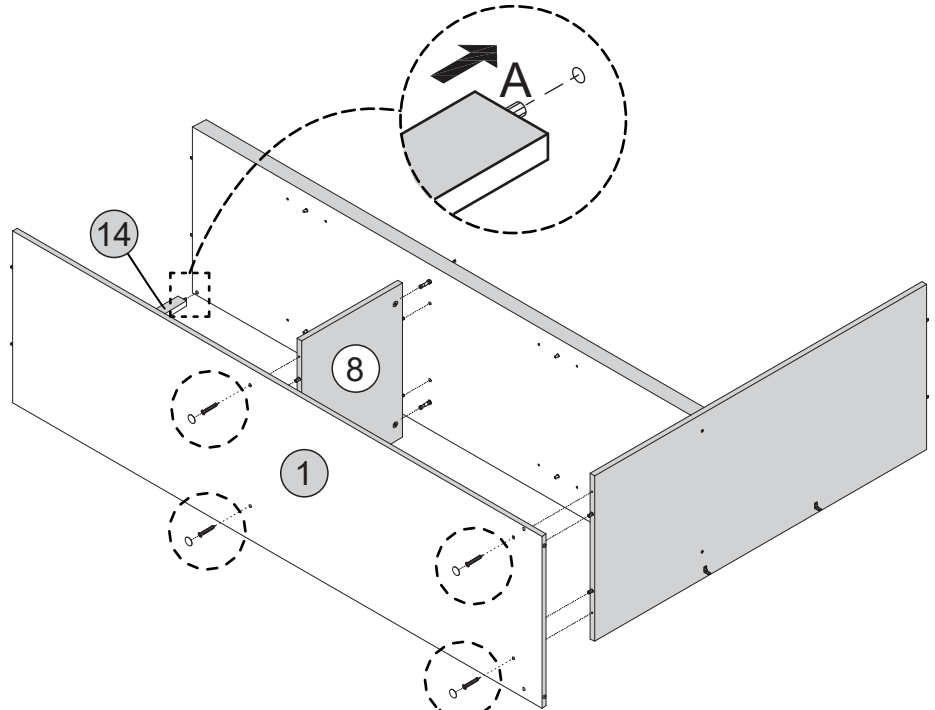
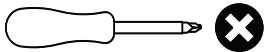

STEP 1

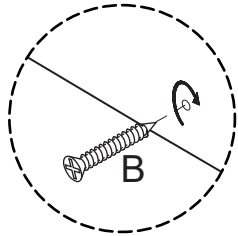

STEP 2

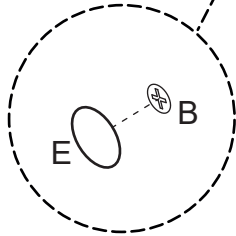

STEP 8

PARTS REQUIRED

6 - LARGE SHELF PANEL x1

11 - BACK SUPPORT PANEL x1

12 - FRONT CROSSBAR x1

13 - LARGE SUPPORT PANEL x1

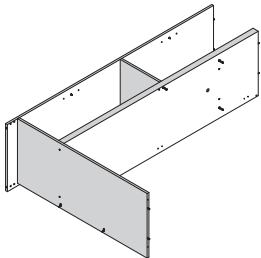

HARDWARE REQUIRED

B  01

E  01

TOOLS REQUIRED

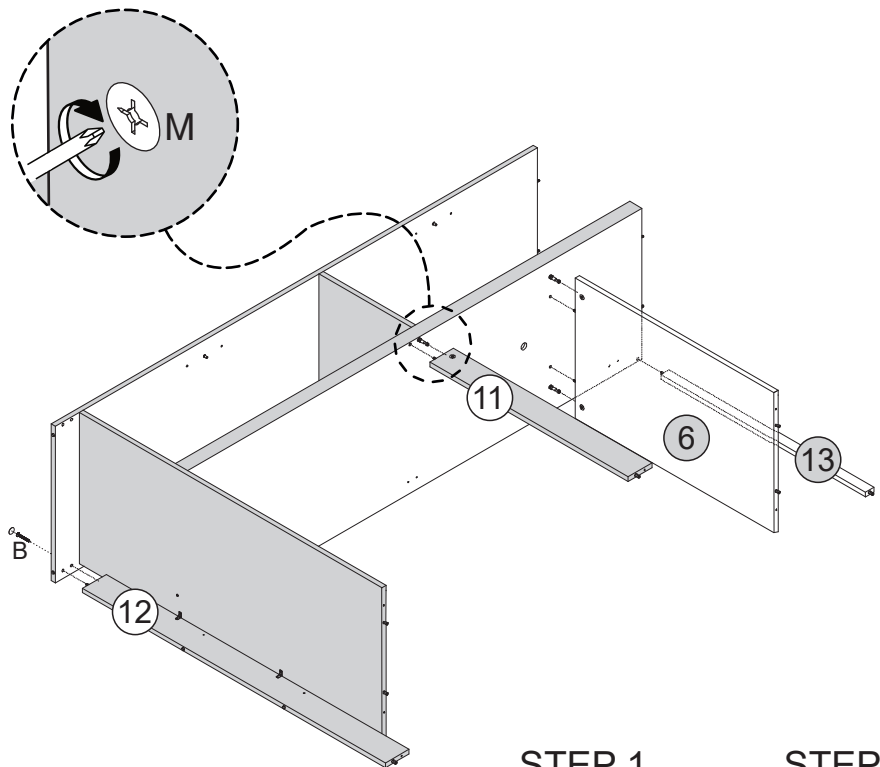
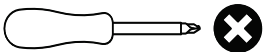

STEP 1

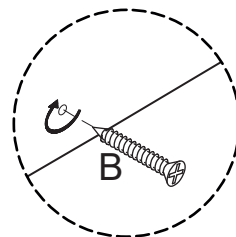

STEP 2

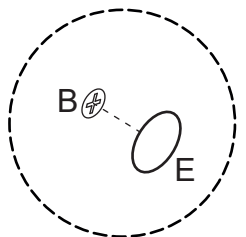

STEP 9

PARTS REQUIRED

2 - LEFT SIDE PANEL x1

15 - BACK CROSSBAR x1

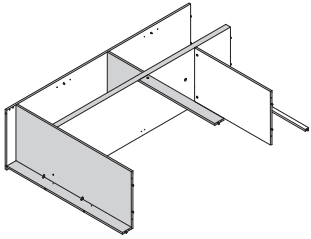

HARDWARE REQUIRED

B  4x45mm 08

E  08

H  01

TOOLS REQUIRED

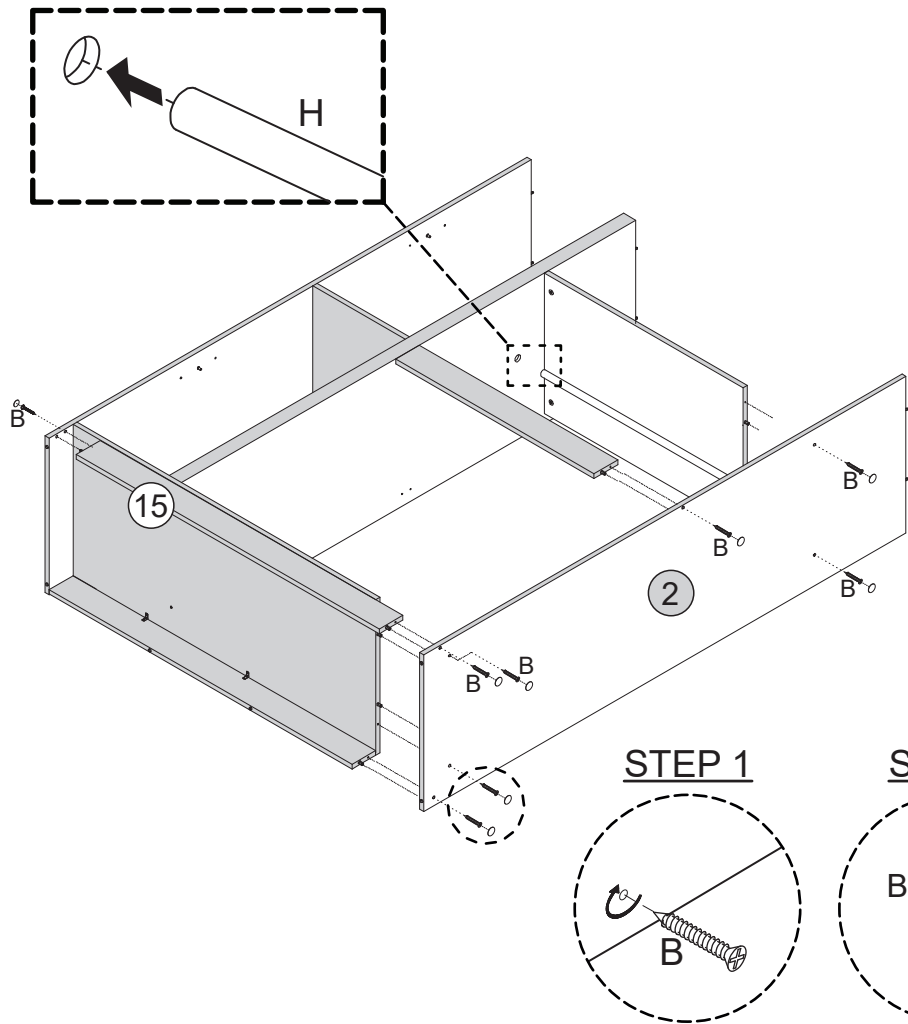
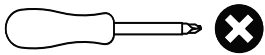

STEP 1

STEP 2

STEP 10

PARTS REQUIRED

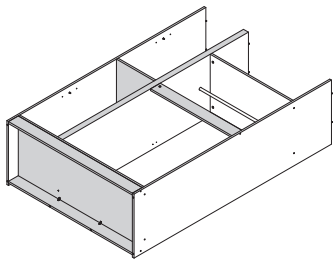

HARDWARE REQUIRED

TOOLS REQUIRED

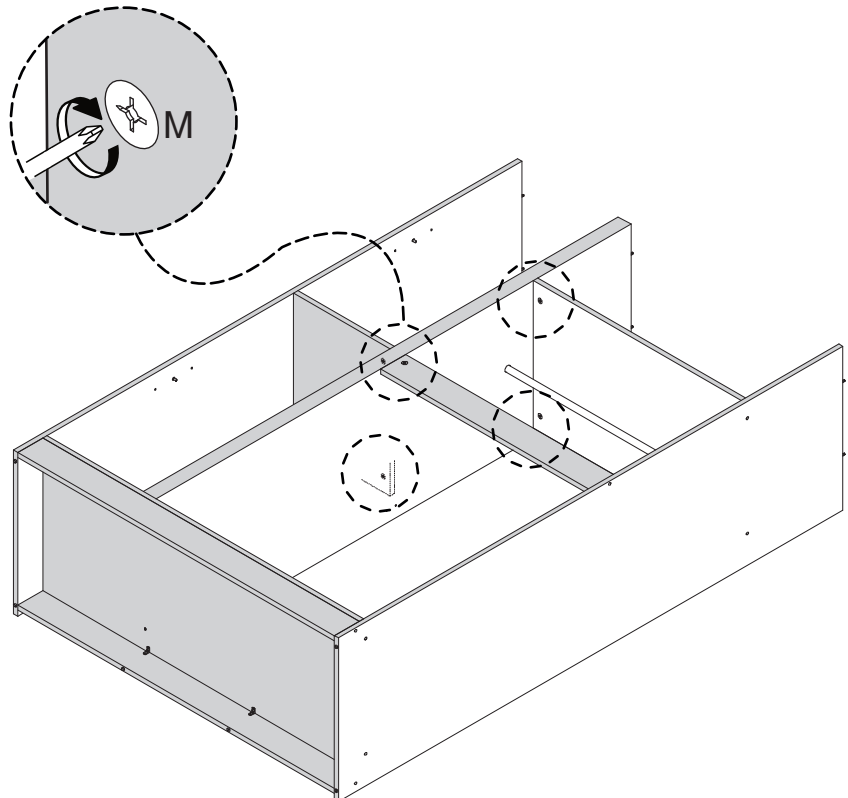
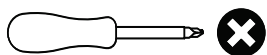

STEP 11

PARTS REQUIRED

9 - TOP PANEL x1

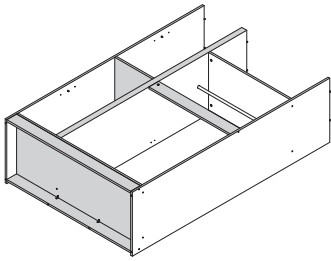

HARDWARE REQUIRED

B  06
4x45mm

TOOLS REQUIRED

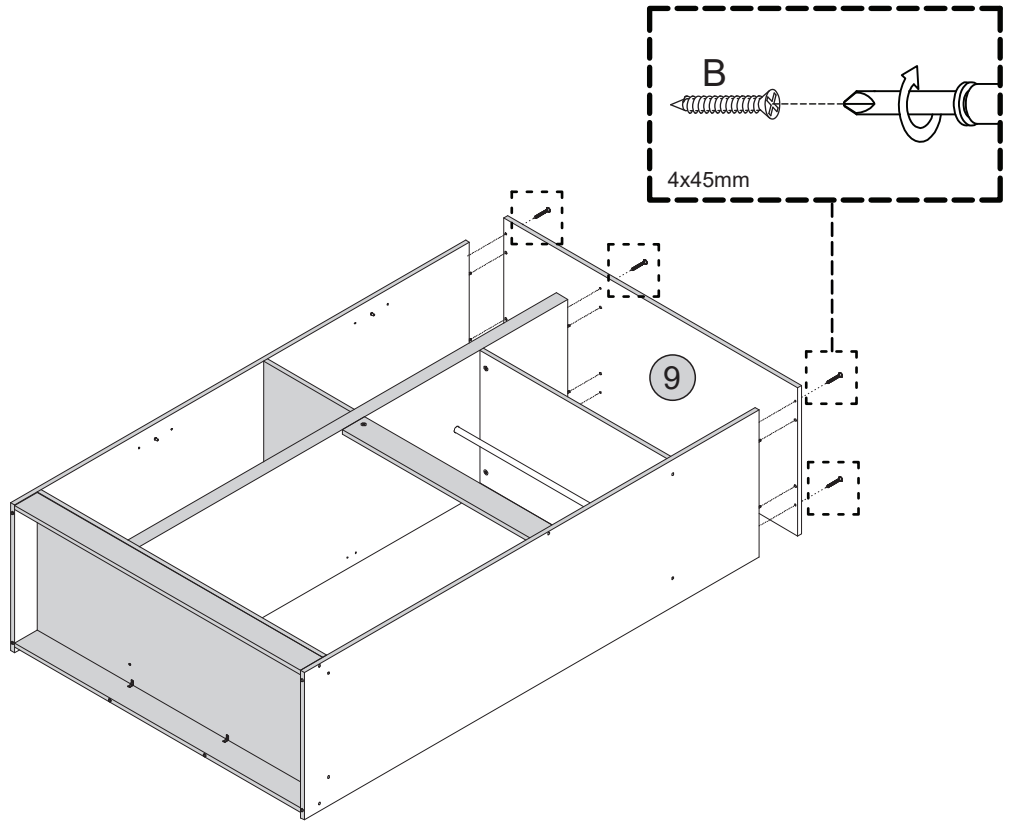
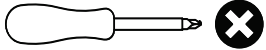

STEP 12

PARTS REQUIRED

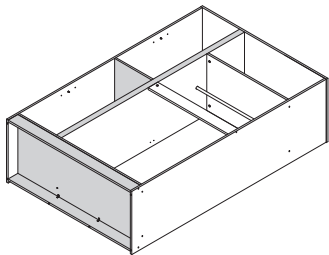

HARDWARE REQUIRED

C  04
3.5x16mm

TOOLS REQUIRED

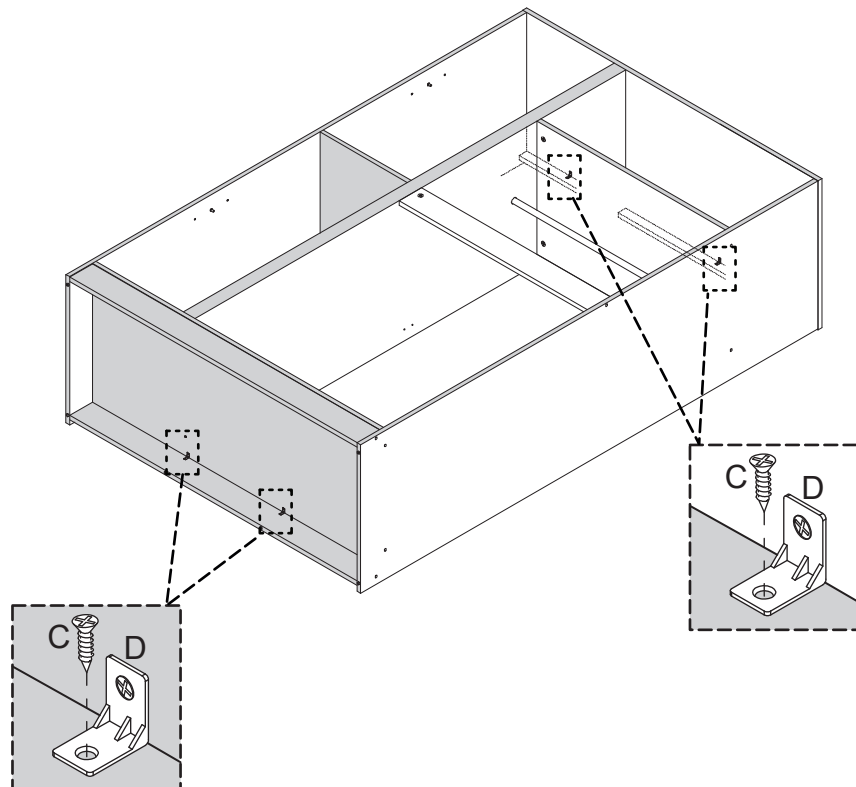
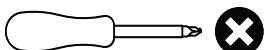

STEP 13

PARTS REQUIRED

18 - LARGE BACK PANEL x1

19 - SMALL BACK PANEL x1

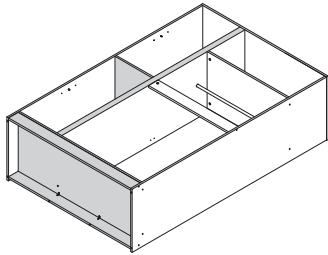

HARDWARE REQUIRED

C  02
3.5x16mm

G  94

TOOLS REQUIRED

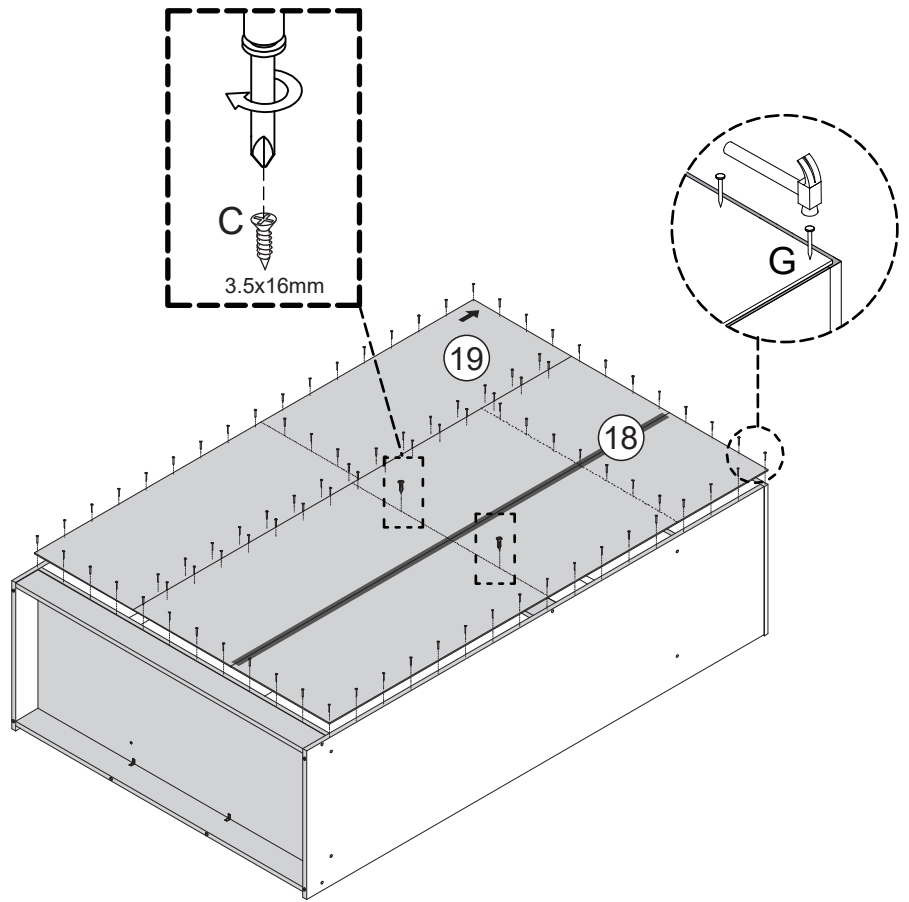
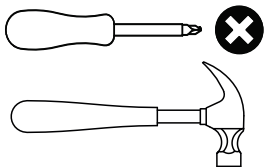

STEP 14

PARTS REQUIRED

7 - SMALL SHELF PANEL x2

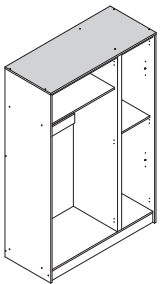

HARDWARE REQUIRED

TOOLS REQUIRED

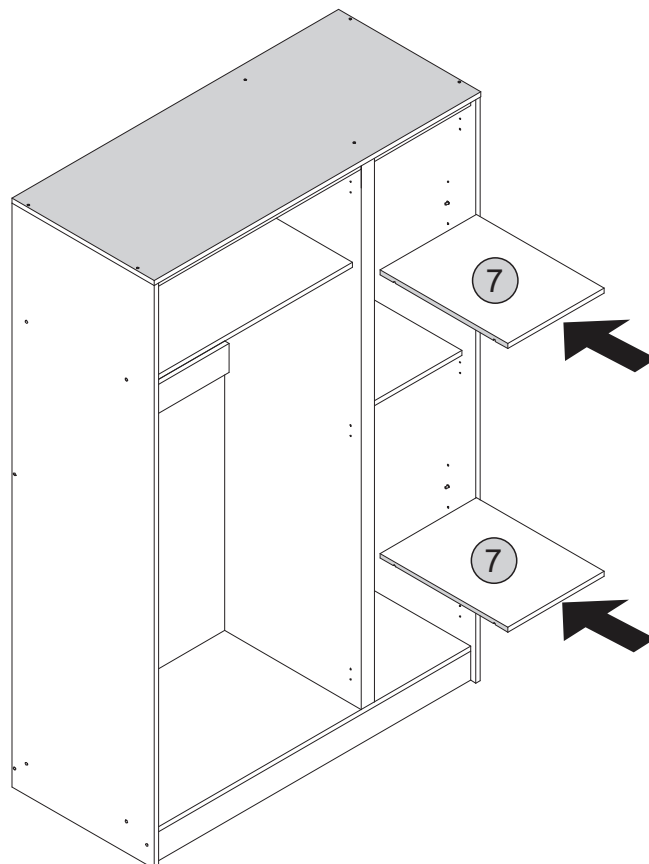

STEP 15

PARTS REQUIRED

- 3 - LEFT DOOR x1
- 5 - RIGHT DOOR x1

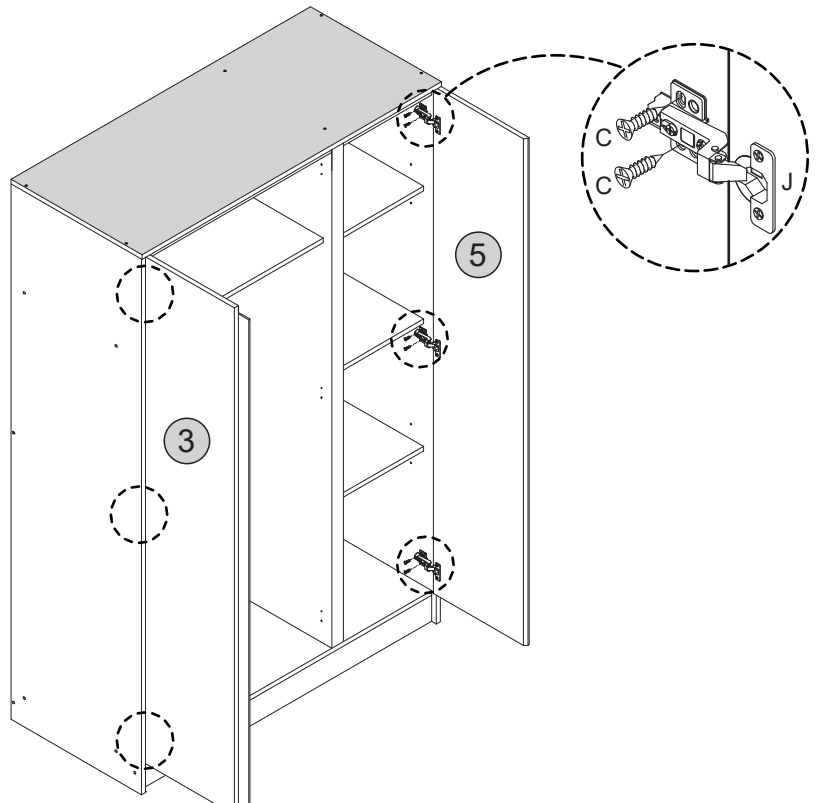
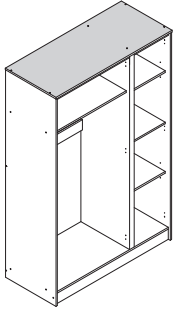

HARDWARE REQUIRED

- C  12

TOOLS REQUIRED

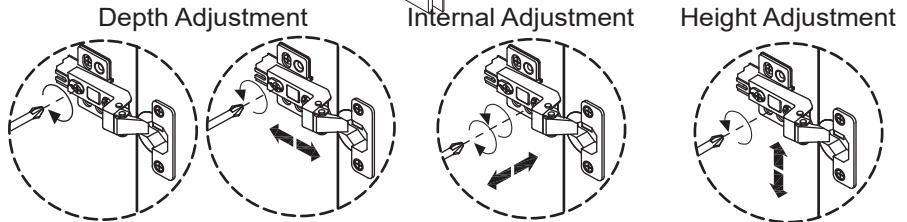
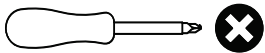

STEP 16

PARTS REQUIRED

- 4 - CENTRE DOOR x1

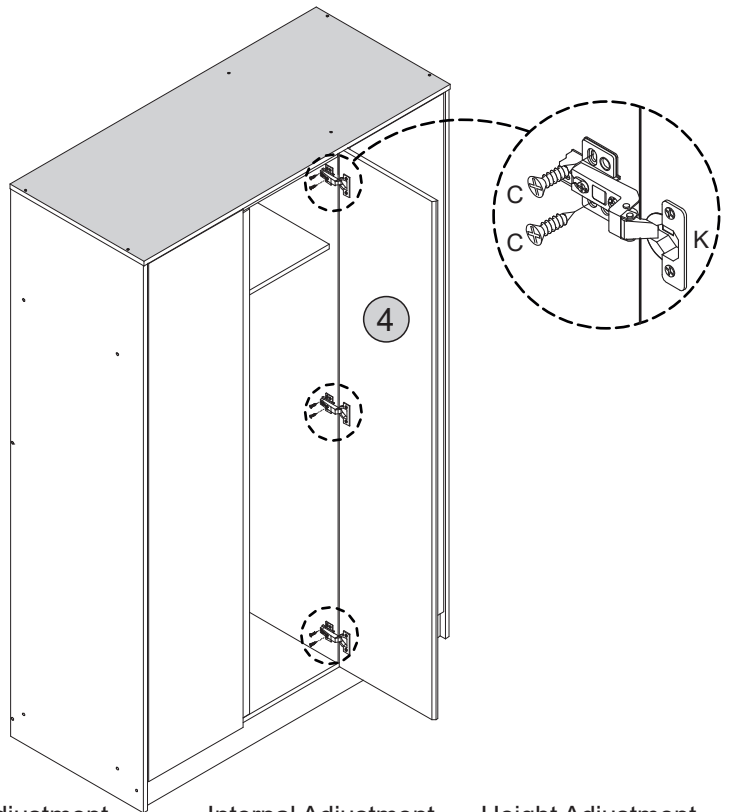
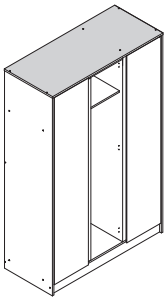

HARDWARE REQUIRED

- C  06

TOOLS REQUIRED

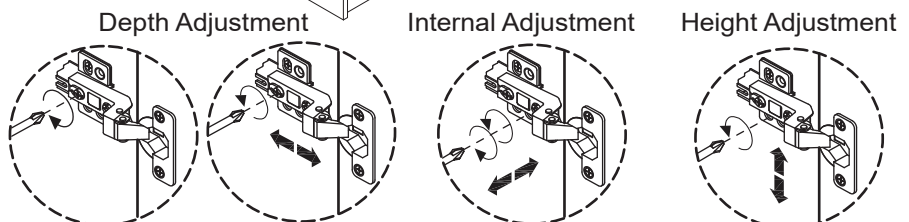
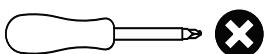

STEP 17

PARTS REQUIRED

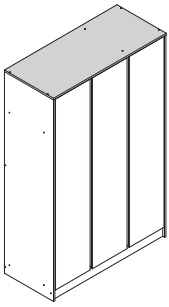

HARDWARE REQUIRED



TOOLS REQUIRED

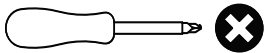

WARNING

Serious or fatal injuries can occur from furniture tipping over. To prevent the furniture from tipping over we recommend that it is permanently fixed to the wall.

Wall fixings are not supplied with this product as different wall materials require different types of fixing devices. Please make sure you use fixings suitable for the walls in your home.

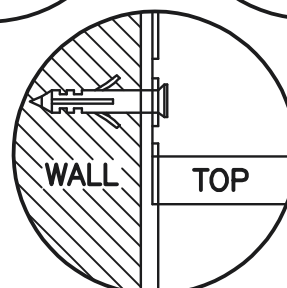
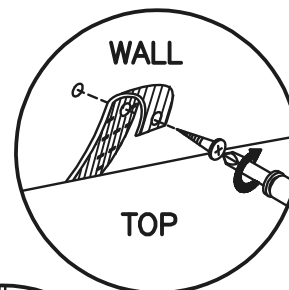
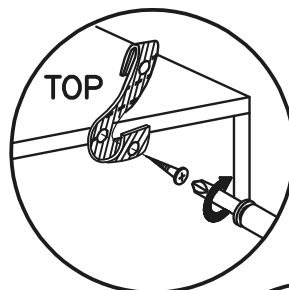
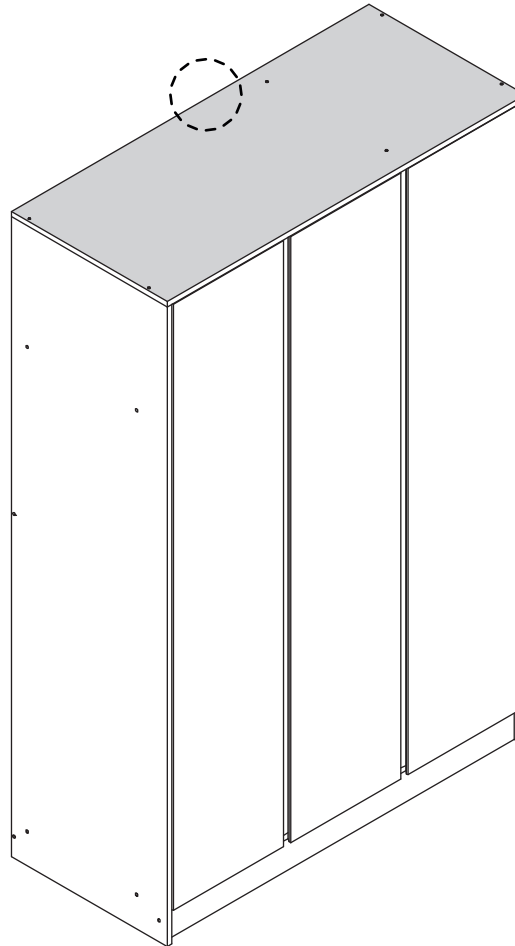

GREY MALVERN 4 DRAWER CHEST ASSEMBLY INSTRUCTIONS

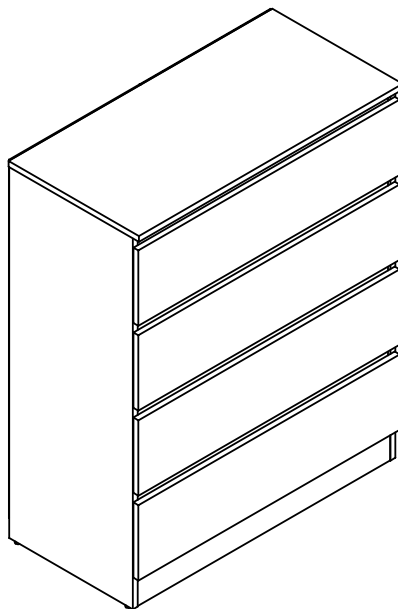

FOR DOMESTIC USE ONLY

IMPORTANT

PLEASE READ BEFORE YOU CONTINUE FURTHER

THE PRODUCT YOU HAVE PURCHASED WILL GIVE YOU MANY YEARS OF SERVICE IF YOU FOLLOW THE GUIDELINES FOR ITS SAFE ASSEMBLY AND PERIODIC MAINTENANCE AND CLEANING.

ASSEMBLE ON A SOFT CLEAN SURFACE.

DO NOT USE ANY TOOLS OTHER THAN THOSE SHOWN.

ANY SPANNERS OR ALLEN KEYS REQUIRED ARE INCLUDED WITH THE FITTING KIT.

DO NOT FOR ANY REASON USE A POWER TOOL TO ASSEMBLE THIS PRODUCT. ITS USE WILL INVALIDATE ANY CLAIM YOU MAY HAVE AND COULD MAKE THIS PRODUCT UNSAFE.

DEPENDING ON THE AMOUNT OF USE THIS PRODUCT RECEIVES. IT MAY BE NECESSARY TO TIGHTEN UP THE FIXINGS FROM TIME TO TIME. THIS IS COMPLETELY NORMAL FOR ANY FLAT PACK FURNITURE. DO NOT OVERTIGHTEN FIXINGS.

FOR CLEANING, YOU MAY USE A DAMP CLOTH (NOT WET). DO NOT USE POLISH, DETERGENT OR CHEMICAL CLEANERS.

THIS SURFACE OF THIS ITEM IS NOT HEAT RESISTANT. ALWAYS USE A PLACE MAT UNDER HOT OR COLD ITEMS TO PREVENT MARKING.

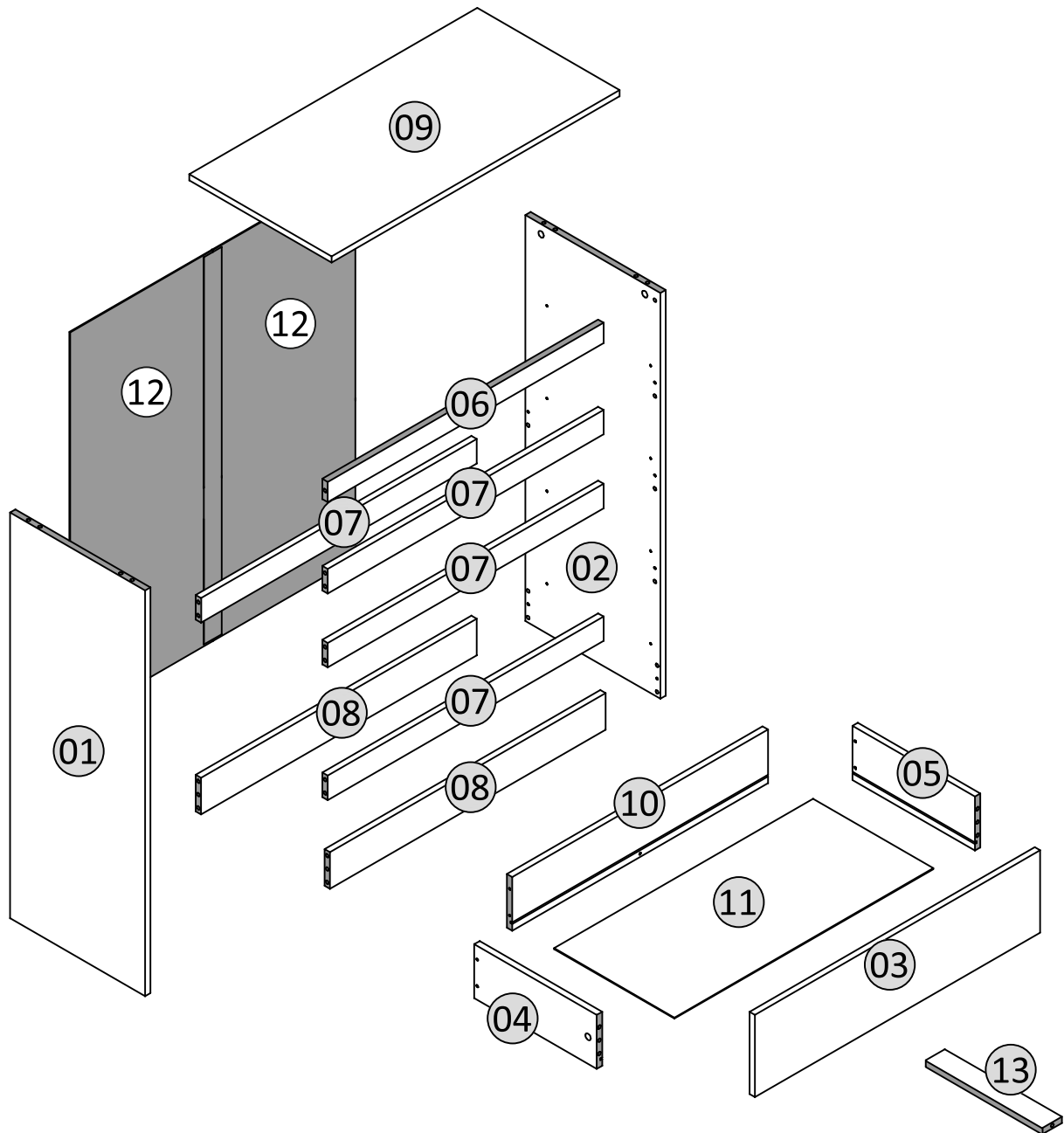

PART LIST

Part Number	Part Code	Part Description	Quantity	Carton
01	S100-102-133-ZF1-01	Left Panel	1	1/2
02	S100-102-133-ZF1-02	Right Panel	1	1/2
03	S100-102-133-ZF1-03	Drawer Front	4	1/2
04	S100-102-133-ZF1-04	Drawer Left Panel	4	2/2
05	S100-102-133-ZF1-05	Drawer Right Panel	4	2/2
06	S100-102-133-ZF1-06	Top Support Panel	1	2/2
07	S100-102-133-ZF1-07	Centre Support Panel	4	2/2
08	S100-102-133-ZF1-08	Bottom Support Panel	2	2/2
09	S100-102-133-ZF1-09	Top Panel	1	1/2
10	S100-102-133-ZF1-10	Drawer Back Panel	4	2/2
11	S100-102-133-ZF1-11	Drawer Bottom Panel	4	1/2
12	S100-102-133-ZF1-12	Back Panel	2	1/2
13	S100-102-133-ZF1-13	Drawer Support Panel	4	1/2

HARDWARE LIST

No.	Part Name		Qty
A	Cam Nut		28
B	Cam Bolt		28
C	M8 x 25mm Wood Dowel		38
D	38mm Chipboard Screw		20
E	14mm Chipboard Screw		44
F	14" Drawer Slide		4 sets
G	PVC L Braket		1
H	Plastic Foot		4
J	18mm Panel Pin		45
K	Wall Fittings (4 x 20mm x 1)		1

TIPS FOR FITTING CAM-LOCKS

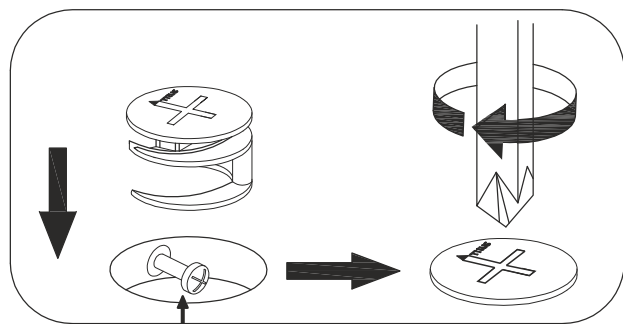
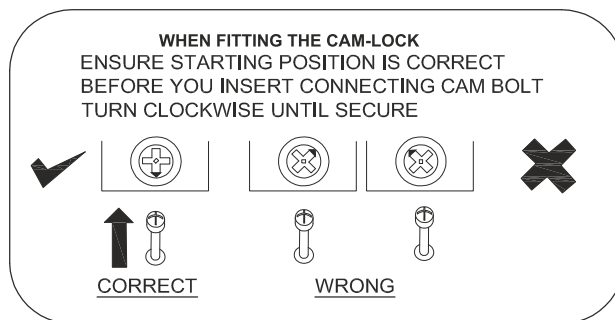

Cam bolt head needs to be in centre

CAMBOLT

Tighten until shoulder is flush with panel. Do not overtighten or undertighten (see example below)

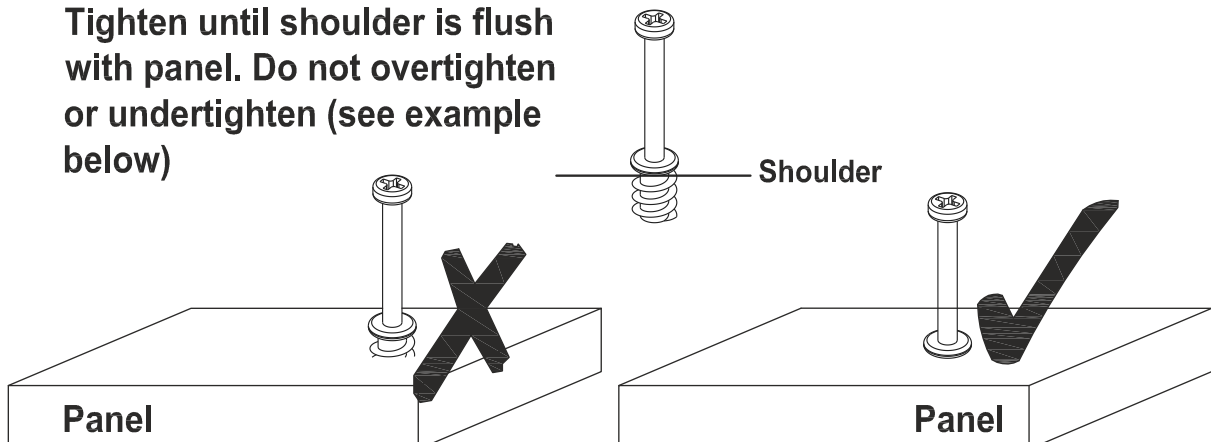

STEP 1

PARTS REQUIRED

01 - LEFT PANEL x1

HARDWARE REQUIRED

E  12

F  04

TOOLS REQUIRED

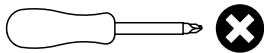

To Assemble the Drawer Slide, Please Follow Step as Below

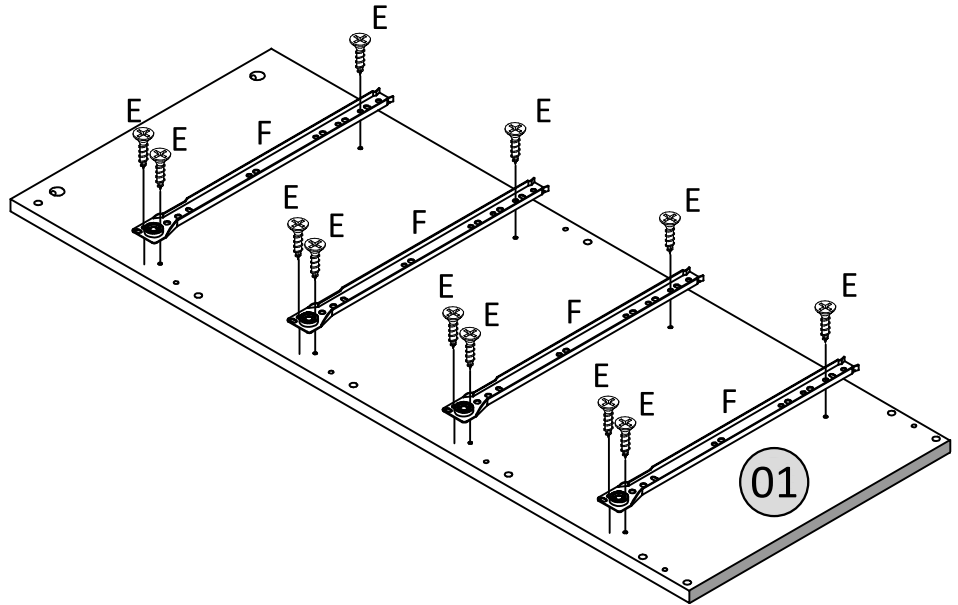

STEP 2

PARTS REQUIRED

02 - RIGHT PANEL x1

HARDWARE REQUIRED

E  12

F  04

TOOLS REQUIRED

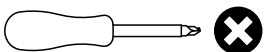

To Assemble the Drawer Slide, Please Follow Step as Below

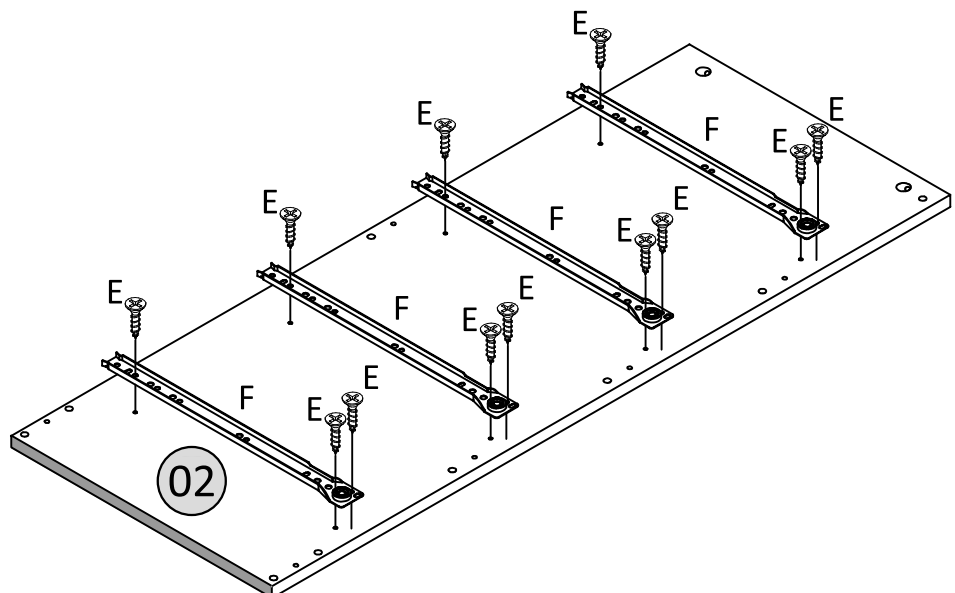



STEP 3

PARTS REQUIRED

01 - LEFT PANEL	x1
02 - RIGHT PANEL	x1

HARDWARE REQUIRED

A		04
B		12
C		04

TOOLS REQUIRED

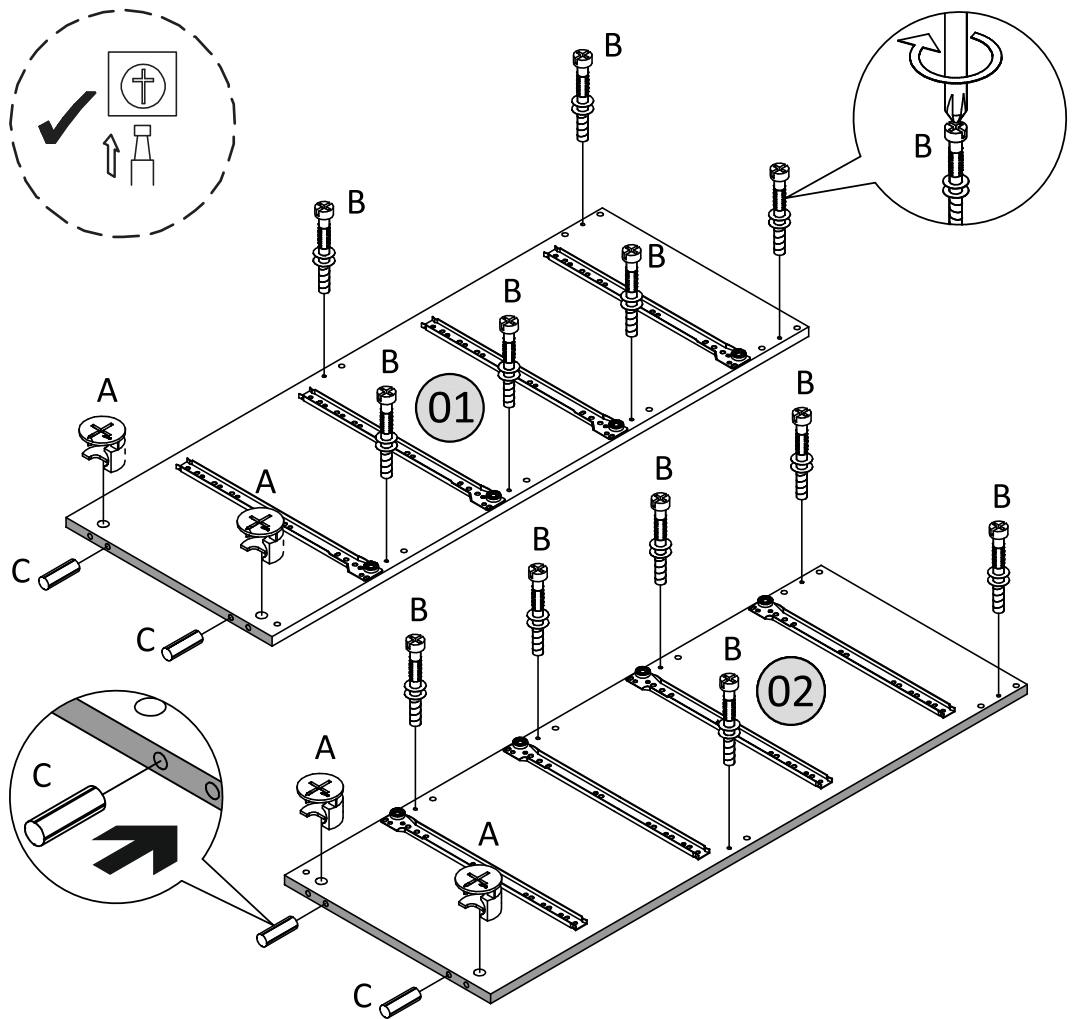
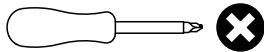



STEP 4

PARTS REQUIRED

06 - TOP SUPPORT PANEL	x1
07 - CENTRE SUPPORT PANEL	x4
08 - BOTTOM SUPPORT PANEL	x2
09 - TOP PANEL	x1

HARDWARE REQUIRED

A		12
B		04
C		18

TOOLS REQUIRED

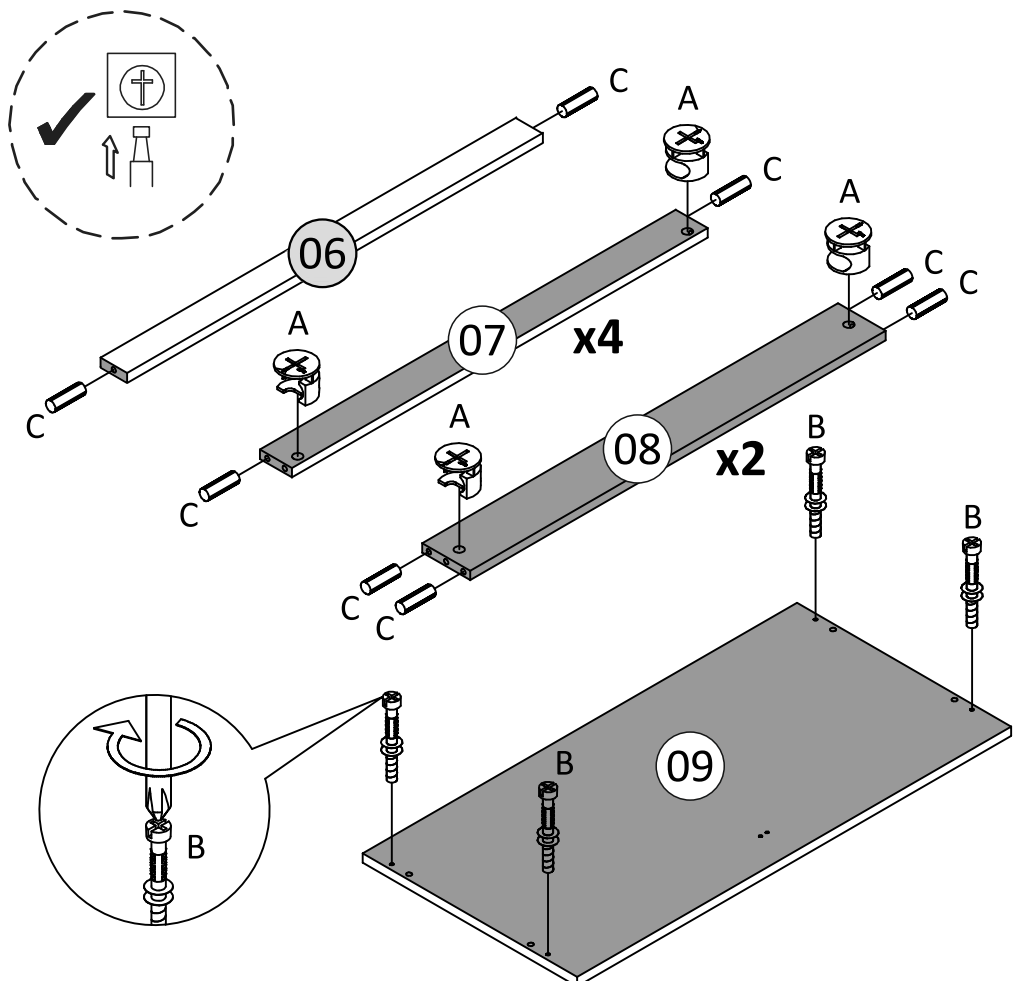
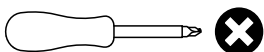

STEP 5

PARTS REQUIRED

- 02 - RIGHT PANEL x1
- 06 - TOP SUPPORT PANEL x1
- 07 - CENTRE SUPPORT PANEL x4
- 08 - BOTTOM SUPPORT PANEL x2

HARDWARE REQUIRED

TOOLS REQUIRED

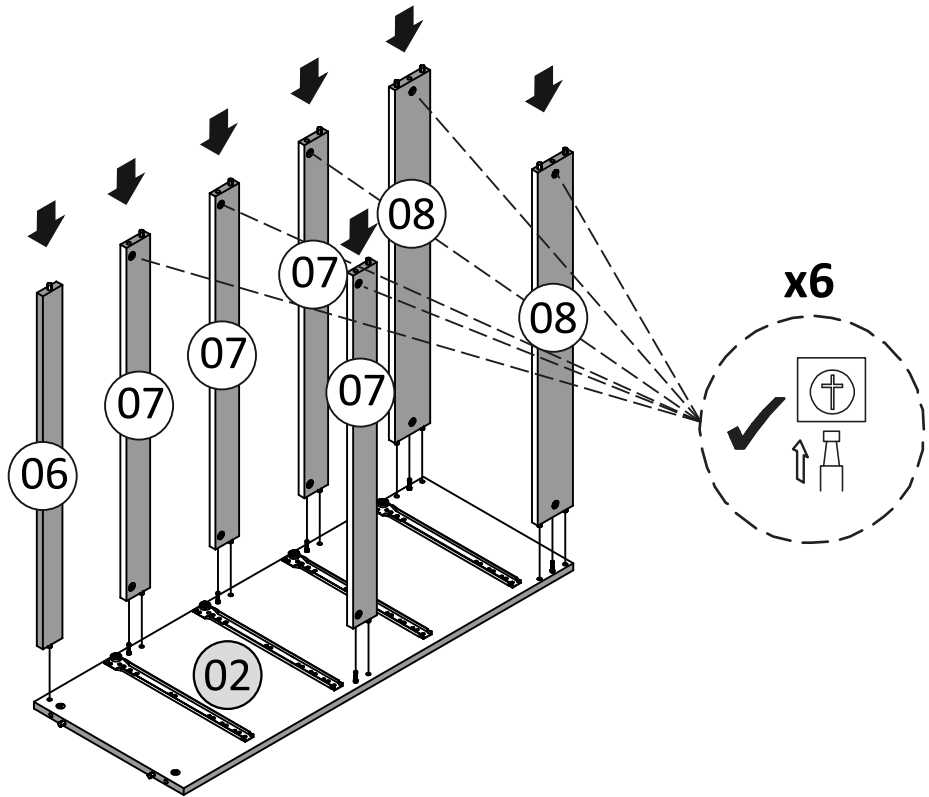
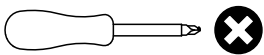

STEP 6

PARTS REQUIRED

- 01 - LEFT PANEL x1

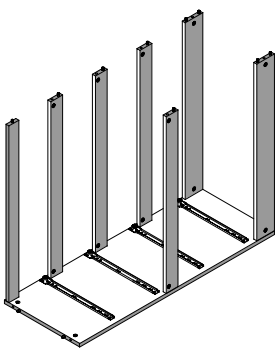

HARDWARE REQUIRED

TOOLS REQUIRED

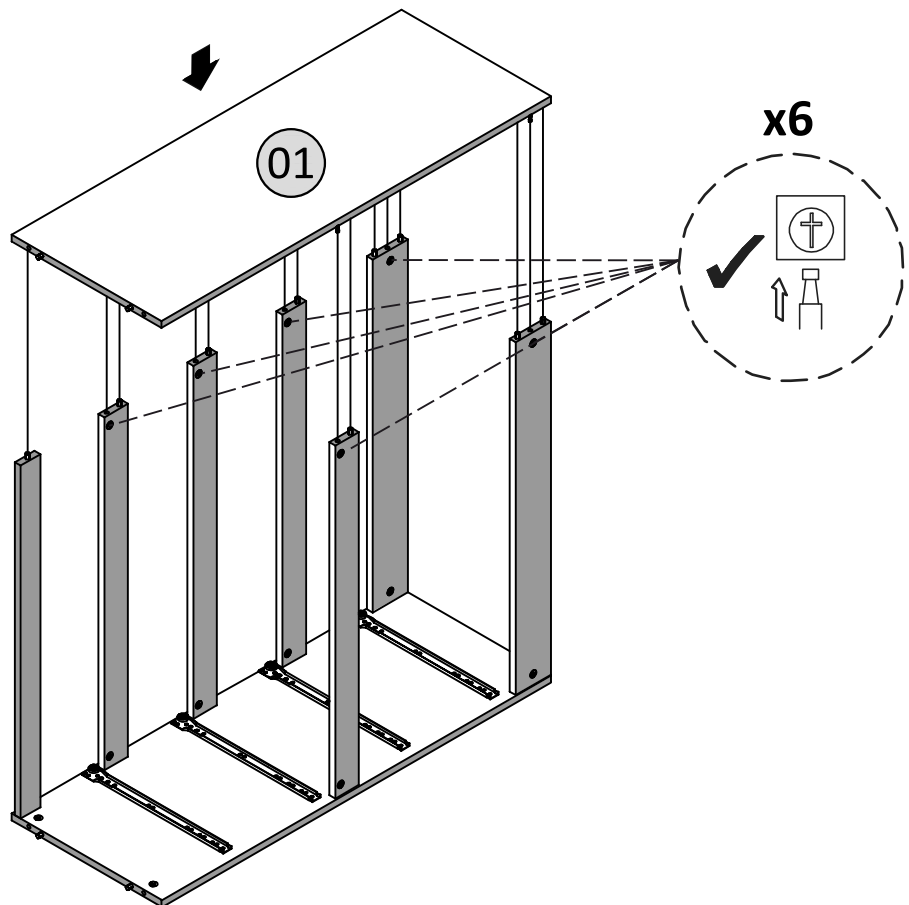
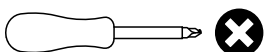

STEP 7

PARTS REQUIRED

09 - TOP PANEL x1

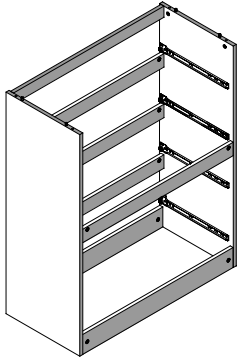

HARDWARE REQUIRED

TOOLS REQUIRED

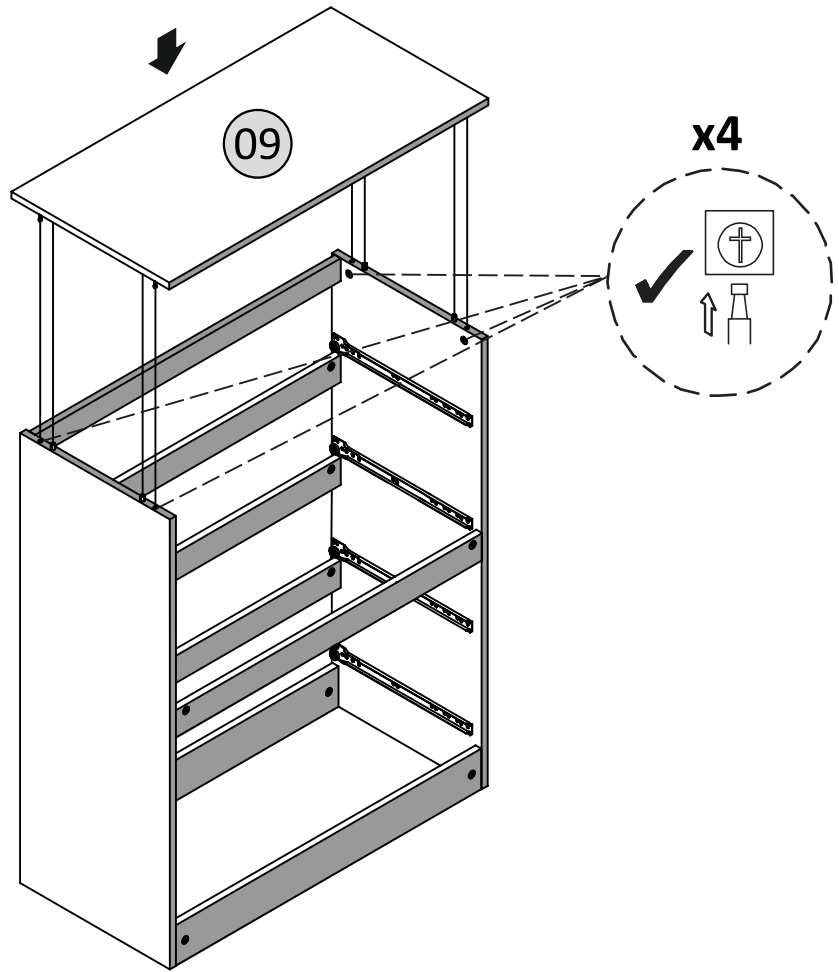
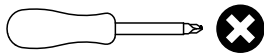

STEP 8

PARTS REQUIRED

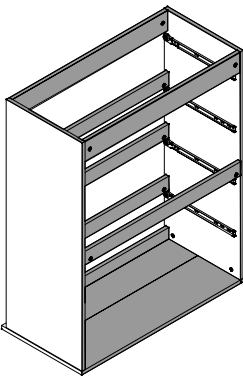

HARDWARE REQUIRED

E  04

G  01

TOOLS REQUIRED

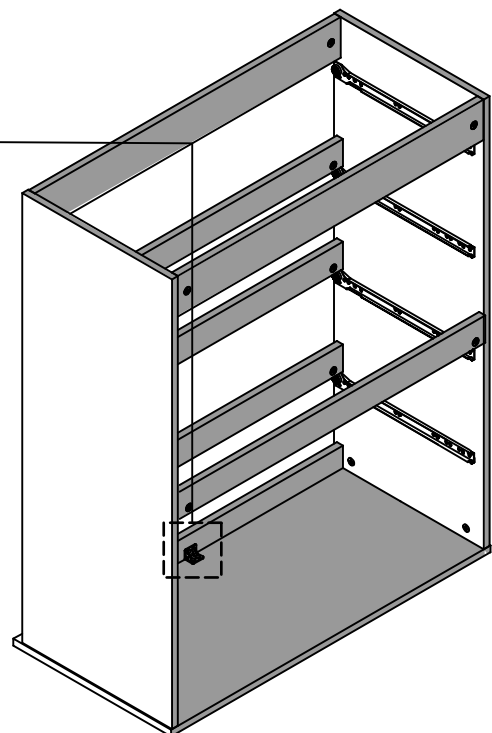
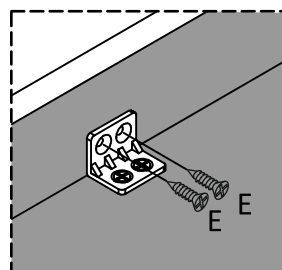
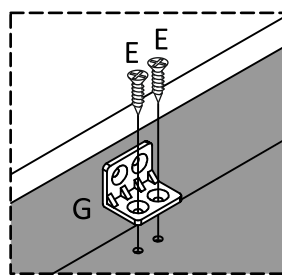
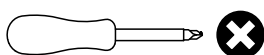

STEP 9

PARTS REQUIRED

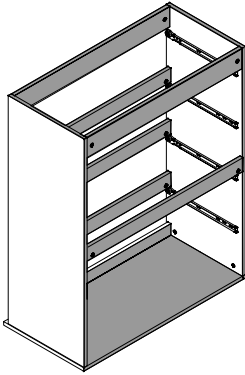

HARDWARE REQUIRED



TOOLS REQUIRED

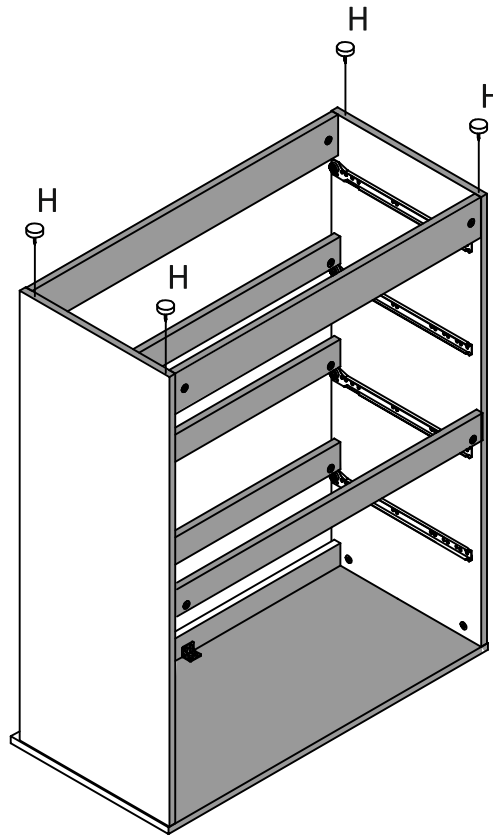
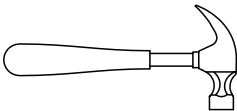

STEP 10

PARTS REQUIRED

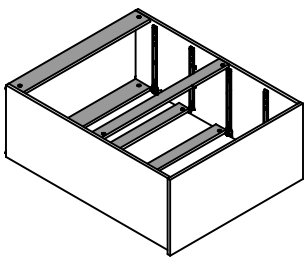

HARDWARE REQUIRED

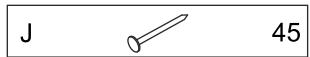

TOOLS REQUIRED

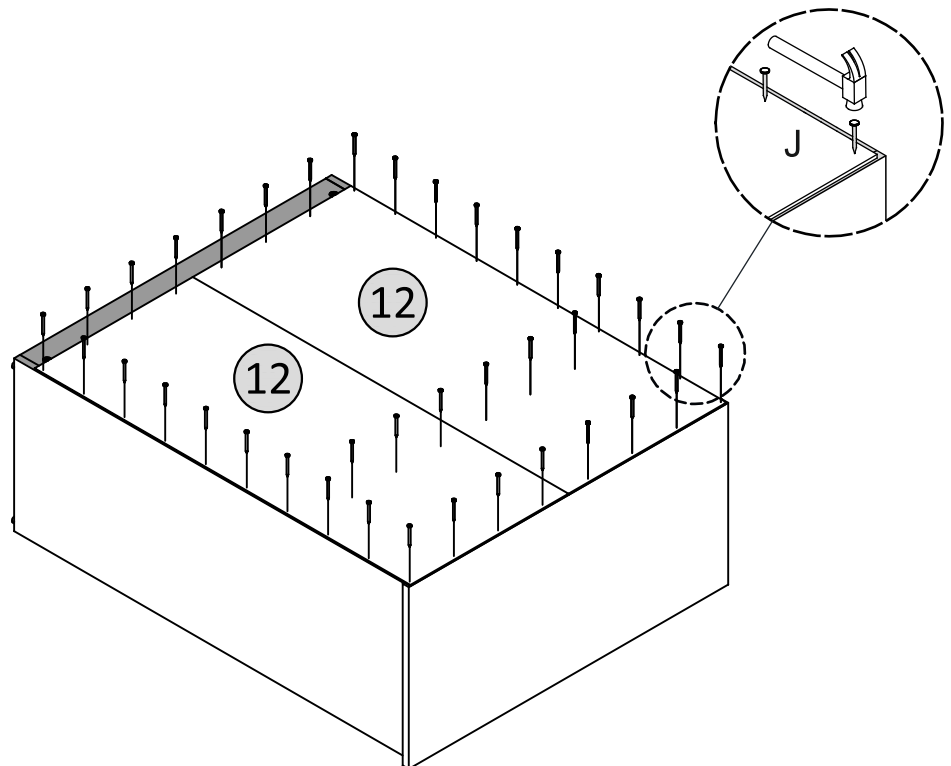
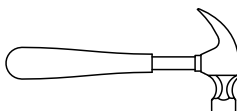



STEP 11

PARTS REQUIRED

03 - DRAWER FRONT	x4
04 - DRAWER LEFT PANEL	x4
05 - DRAWER RIGHT PANEL	x4
13- DRAWER SUPPORT PANEL x4	

HARDWARE REQUIRED

A		12
B		12
C		16

TOOLS REQUIRED

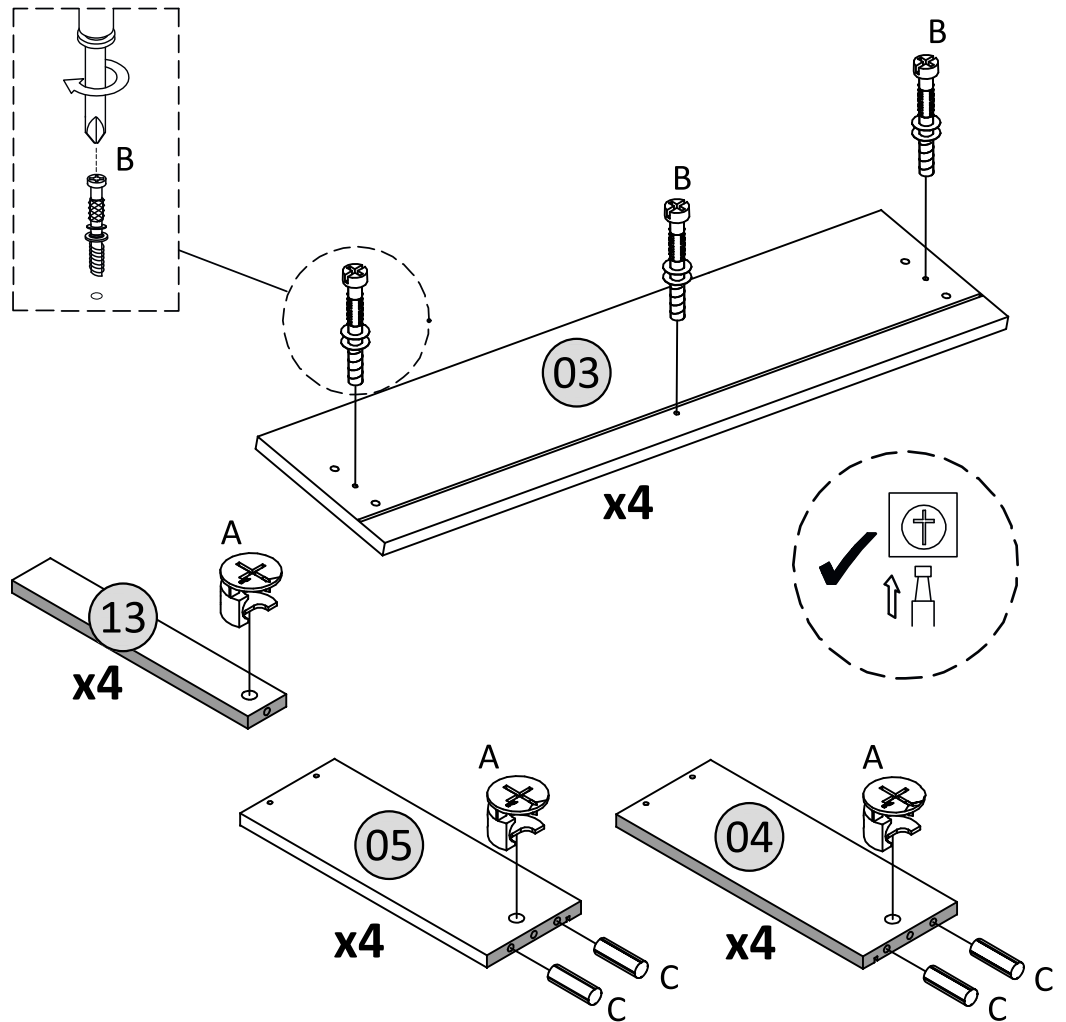
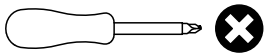

STEP 12

PARTS REQUIRED

04 - DRAWER LEFT PANEL	x4
05 - DRAWER RIGHT PANEL	x4
10- DRAWER BACK PANEL	x4
11- DRAWER BOTTOM PANEL	x4
13- DRAWER SUPPORT PANEL x4	

HARDWARE REQUIRED

D		20
---	---	----

TOOLS REQUIRED

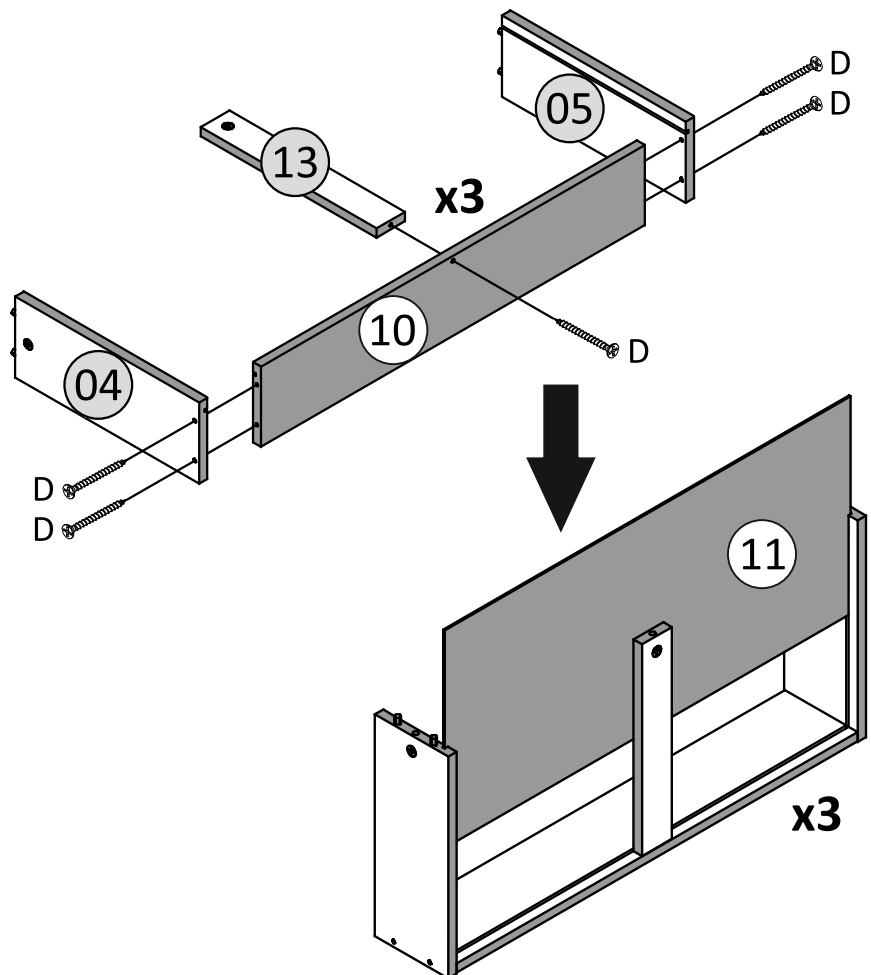
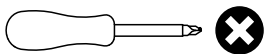

STEP 13

PARTS REQUIRED

03 - DRAWER FRONT x4

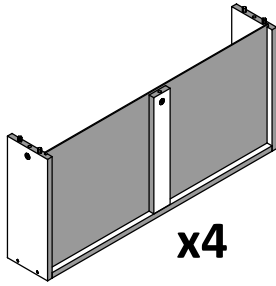

HARDWARE REQUIRED

E  16

F  04

TOOLS REQUIRED

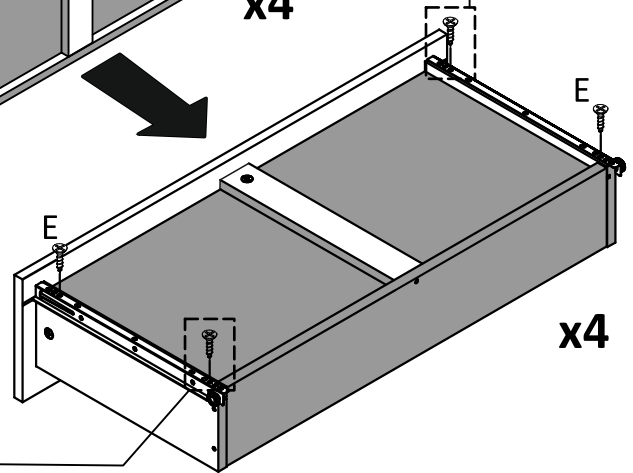
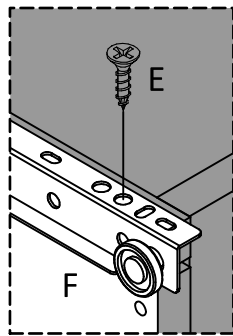
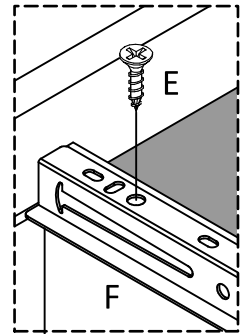
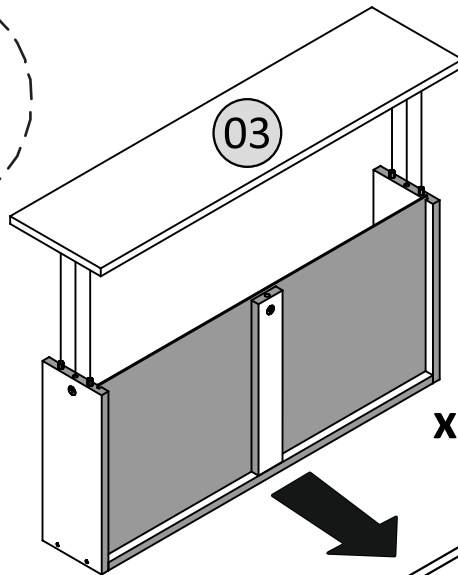
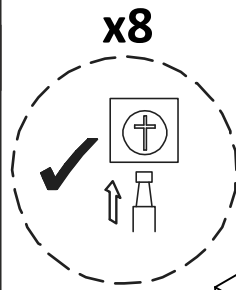
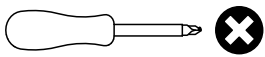

STEP 14

PARTS REQUIRED

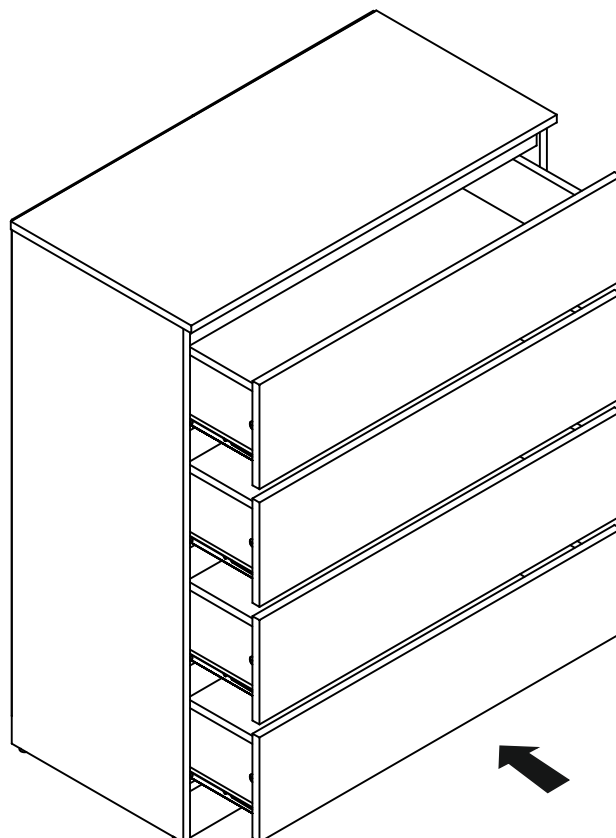
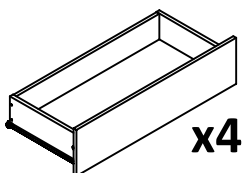
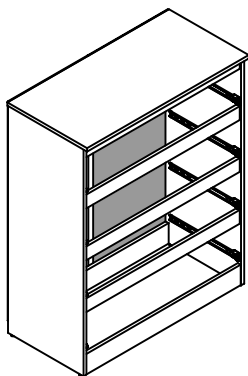

STEP 15

PARTS REQUIRED

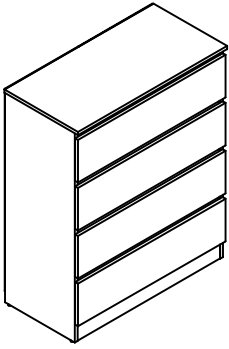

HARDWARE REQUIRED

K  01

TOOLS REQUIRED

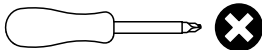

WARNING

Serious or fatal injuries can occur from furniture tipping over. To prevent the furniture from tipping over we recommend that it is permanently fixed to the wall.

Wall fixings are not supplied with this product as different wall materials require different types of fixing devices. Please make sure you use fixings suitable for the walls in your home.

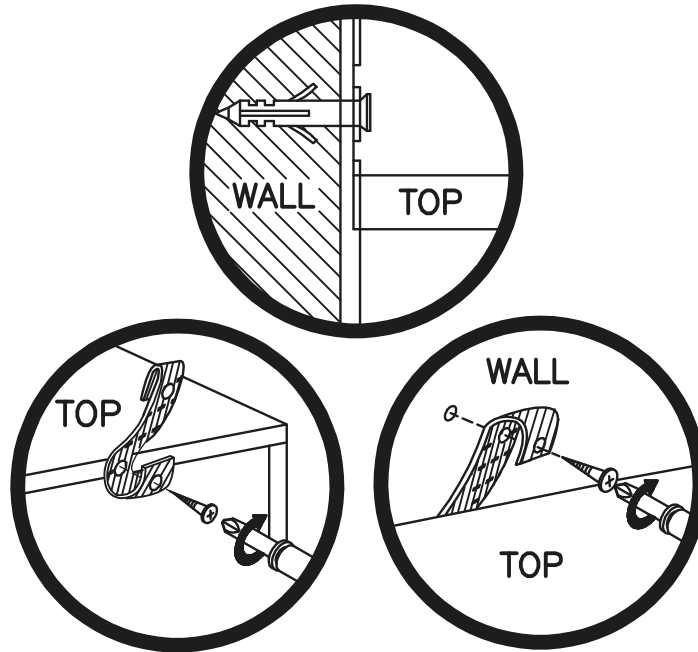

STEP 16

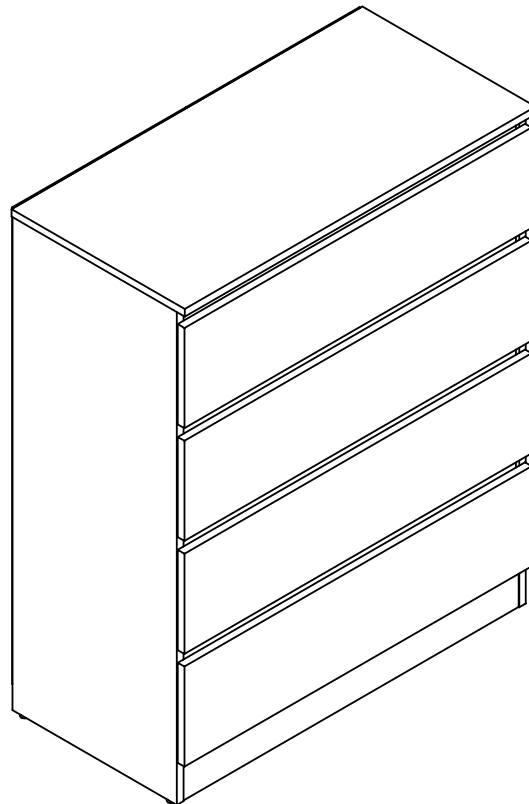

FINISH

GREY MALVERN 3 DRAWER BEDSIDE ASSEMBLY INSTRUCTIONS

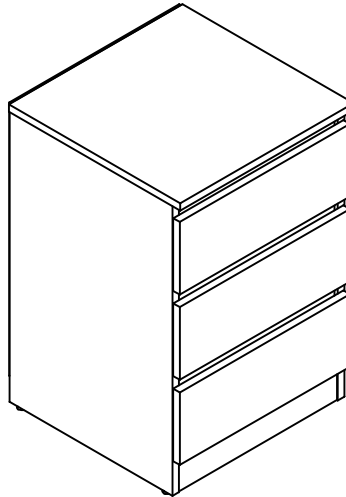

FOR DOMESTIC USE ONLY

IMPORTANT

PLEASE READ BEFORE YOU CONTINUE FURTHER

THE PRODUCT YOU HAVE PURCHASED WILL GIVE YOU MANY YEARS OF SERVICE IF YOU FOLLOW THE GUIDELINES FOR ITS SAFE ASSEMBLY AND PERIODIC MAINTENANCE AND CLEANING.

ASSEMBLE ON A SOFT CLEAN SURFACE.

DO NOT USE ANY TOOLS OTHER THAN THOSE SHOWN.

ANY SPANNERS OR ALLEN KEYS REQUIRED ARE INCLUDED WITH THE FITTING KIT.

DO NOT FOR ANY REASON USE A POWER TOOL TO ASSEMBLE THIS PRODUCT. ITS USE WILL INVALIDATE ANY CLAIM YOU MAY HAVE AND COULD MAKE THIS PRODUCT UNSAFE.

DEPENDING ON THE AMOUNT OF USE THIS PRODUCT RECEIVES. IT MAY BE NECESSARY TO TIGHTEN UP THE FIXINGS FROM TIME TO TIME. THIS IS COMPLETELY NORMAL FOR ANY FLAT PACK FURNITURE. DO NOT OVERTIGHTEN FIXINGS.

FOR CLEANING, YOU MAY USE A DAMP CLOTH (NOT WET). DO NOT USE POLISH, DETERGENT OR CHEMICAL CLEANERS.

THIS SURFACE OF THIS ITEM IS NOT HEAT RESISTANT. ALWAYS USE A PLACE MAT UNDER HOT OR COLD ITEMS TO PREVENT MARKING.

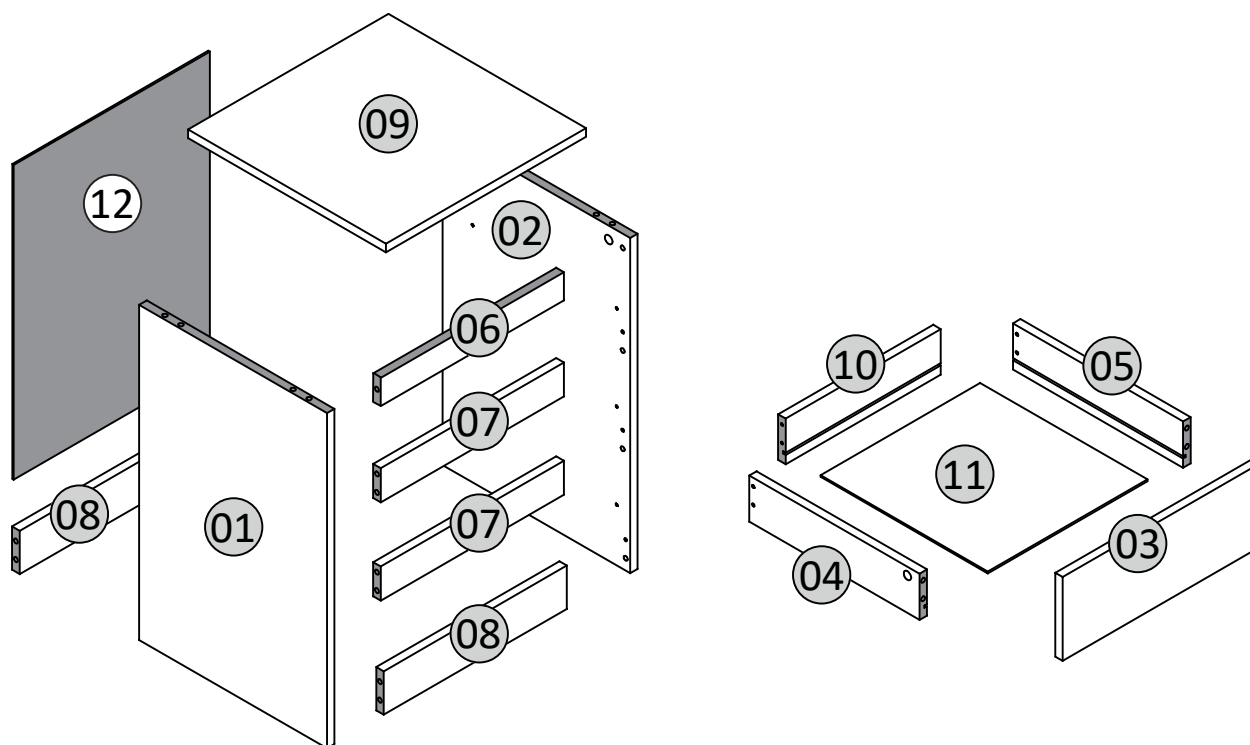

PART LIST

<u>Part Number</u>	<u>Part Code</u>	<u>Part Description</u>	<u>Quantity</u>	<u>Carton</u>
01	S100-103-069-ZF1-01	Left Panel	1	1/1
02	S100-103-069-ZF1-02	Right Panel	1	1/1
03	S100-103-069-ZF1-03	Drawer Front	3	1/1
04	S100-103-069-ZF1-04	Drawer Left Panel	3	1/1
05	S100-103-069-ZF1-05	Drawer Right Panel	3	1/1
06	S100-103-069-ZF1-06	Top Support Panel	1	1/1
07	S100-103-069-ZF1-07	Centre Support Panel	2	1/1
08	S100-103-069-ZF1-08	Bottom Support Panel	2	1/1
09	S100-103-069-ZF1-09	Top Panel	1	1/1
10	S100-103-069-ZF1-10	Drawer Back Panel	3	1/1
11	S100-103-069-ZF1-11	Drawer Bottom Panel	3	1/1
12	S100-103-069-ZF1-12	Back Panel	1	1/1

HARDWARE LIST

No.	Part Name		Qty
A	Cam Nut		18
B	Cam Bolt		18
C	M8 x 25mm Wood Dowel		20
D	38mm Chipboard Screw		12
E	14mm Chipboard Screw		34
F	14" Drawer Slide		3 sets
G	PVC L Bracket		1
H	Plastic Foot		4
J	18mm Panel Pin		20
K	Wall Fittings (4 x 20mm x 1)		1

TIPS FOR FITTING CAM-LOCKS

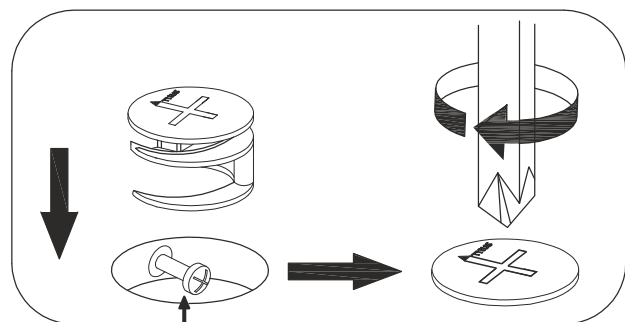
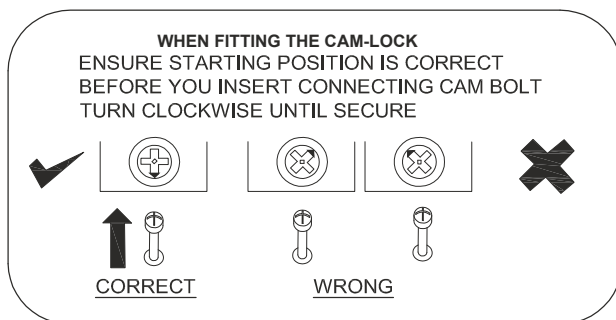

Cam bolt head needs to be in centre

CAMBOLT

Tighten until shoulder is flush with panel. Do not overtighten or undertighten (see example below)

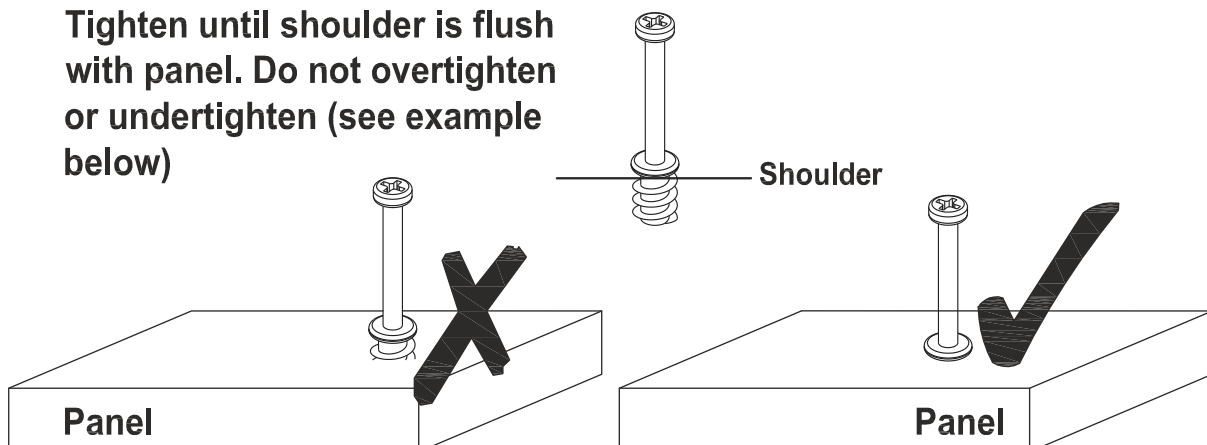

STEP 1

PARTS REQUIRED

01 - LEFT PANEL x1

HARDWARE REQUIRED

E  09

F  03

TOOLS REQUIRED

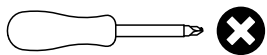

To Assemble the Drawer Slide, Please Follow Step as Below

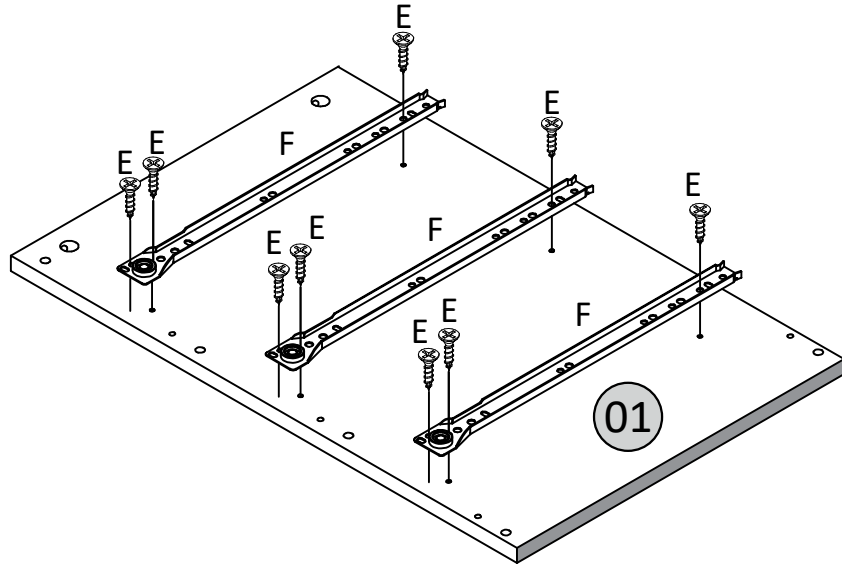
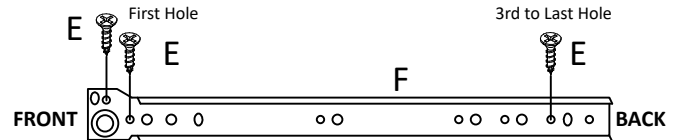

STEP 2

PARTS REQUIRED

02 - RIGHT PANEL x1

HARDWARE REQUIRED

E  09

F  03

TOOLS REQUIRED

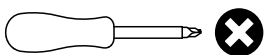

To Assemble the Drawer Slide, Please Follow Step as Below

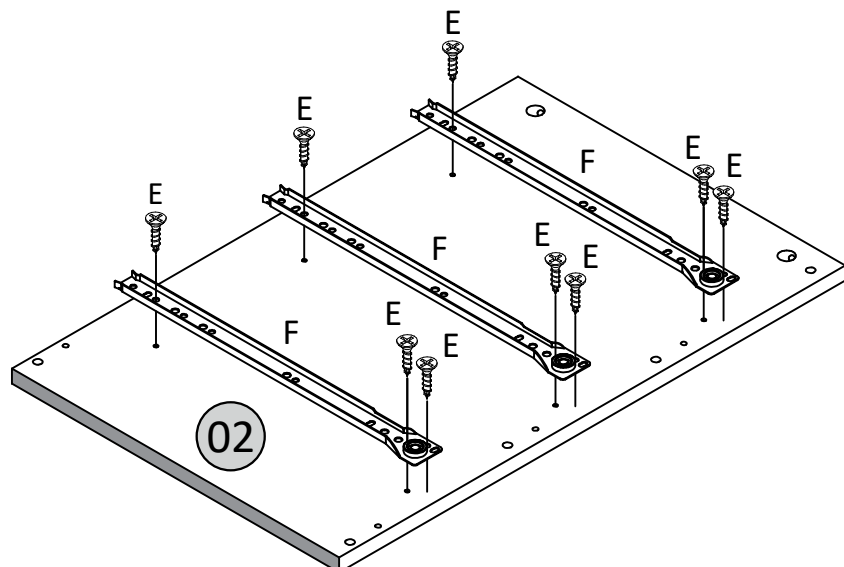

STEP 3

PARTS REQUIRED

01 - LEFT PANEL x1

02 - RIGHT PANEL x1

HARDWARE REQUIRED

A  04

B  08

C  04

TOOLS REQUIRED

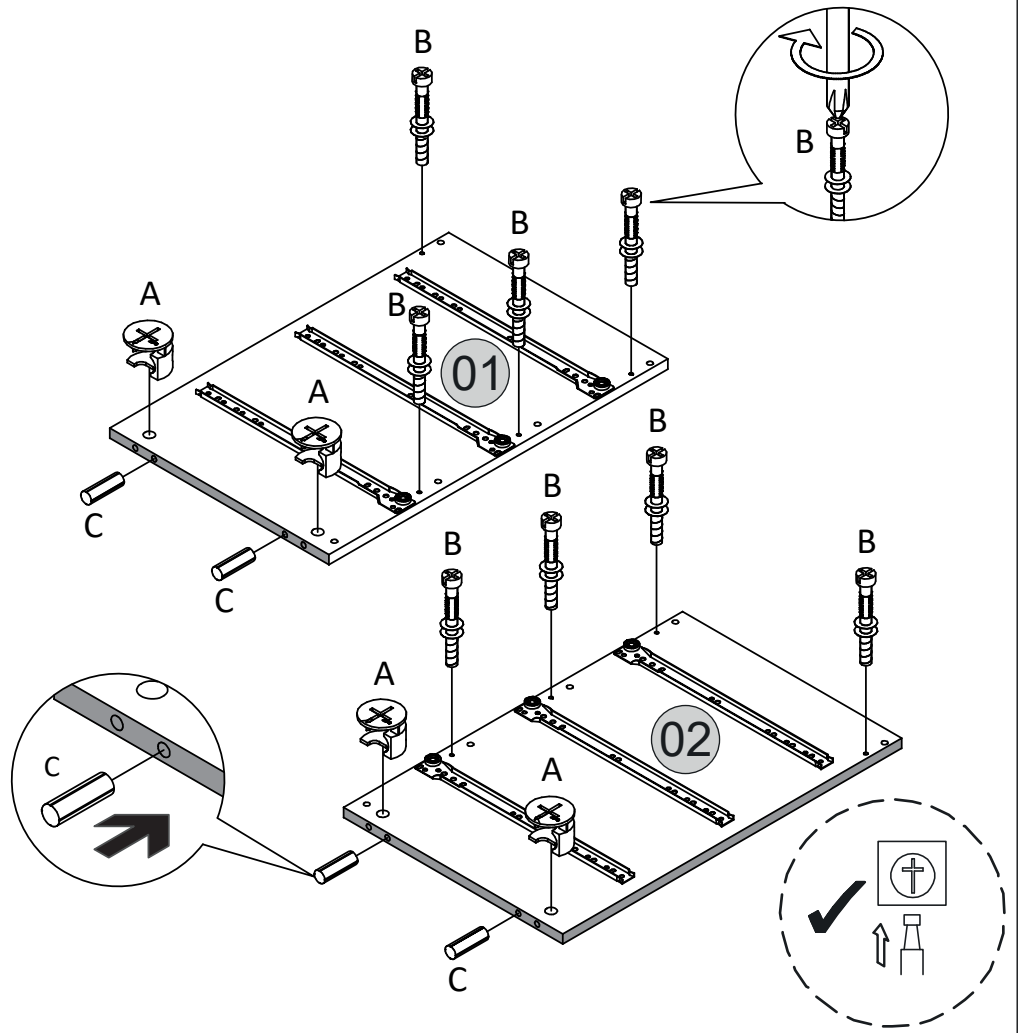
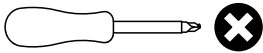

STEP 4

PARTS REQUIRED

06 - TOP SUPPORT PANEL x1

07 - CENTRE SUPPORT PANEL x1

08 - BOTTOM SUPPORT PANEL x1

09 - TOP PANEL x1

HARDWARE REQUIRED

A  08

B  04

C  10

TOOLS REQUIRED

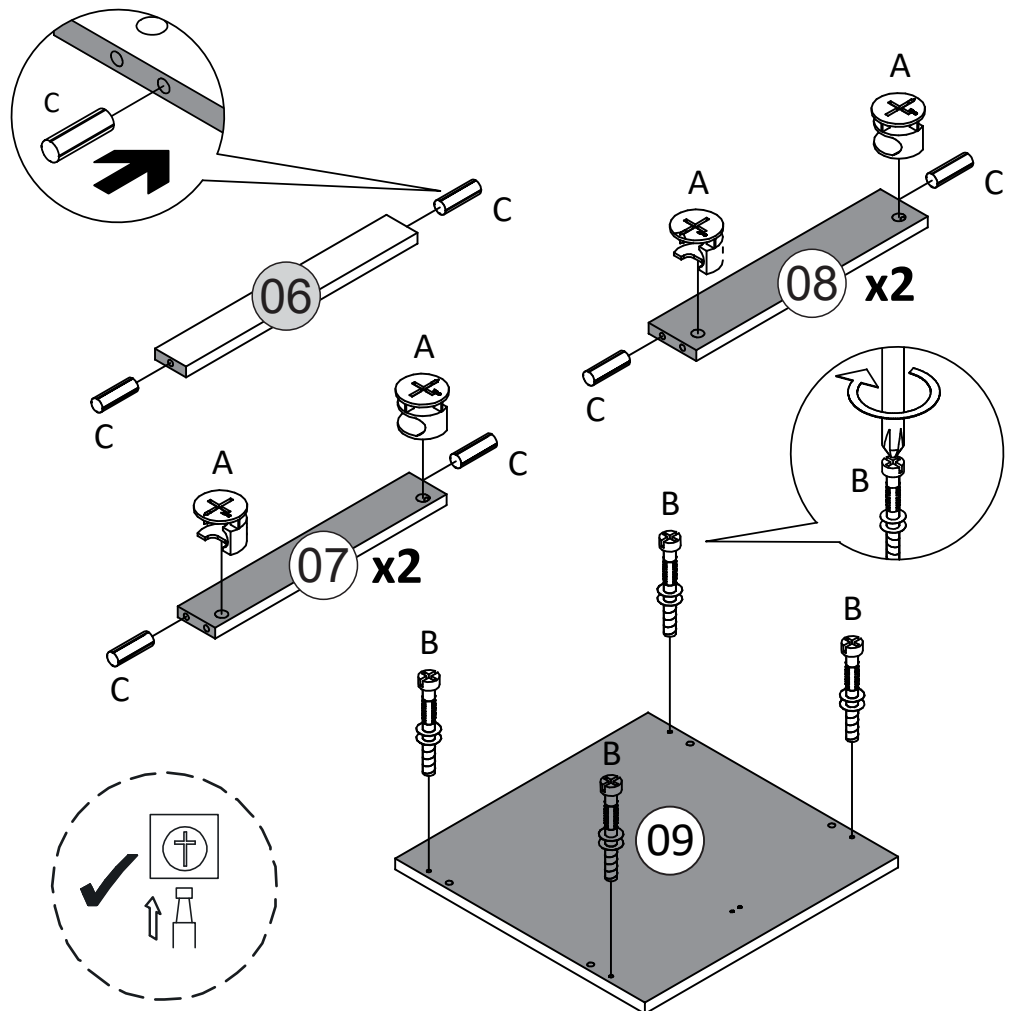
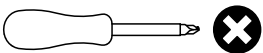

STEP 5

PARTS REQUIRED

02 - RIGHT PANEL x1

06 - TOP SUPPORT PANEL x1

07 - CENTRE SUPPORT PANEL x2

08 - BOTTOM SUPPORT PANEL x2

HARDWARE REQUIRED

TOOLS REQUIRED

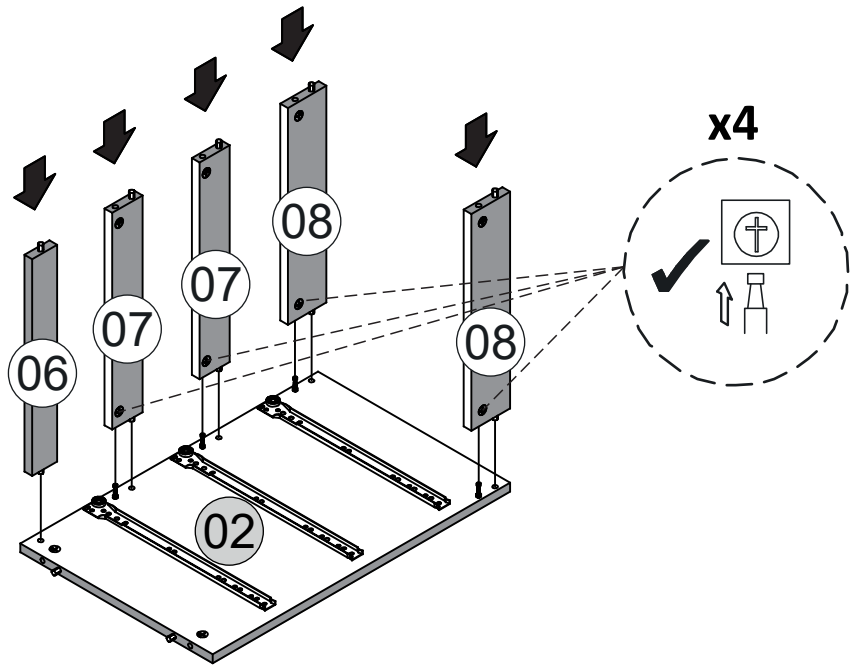
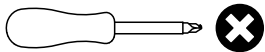

STEP 6

PARTS REQUIRED

01 - LEFT PANEL x1

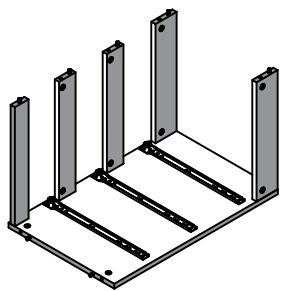

HARDWARE REQUIRED

TOOLS REQUIRED

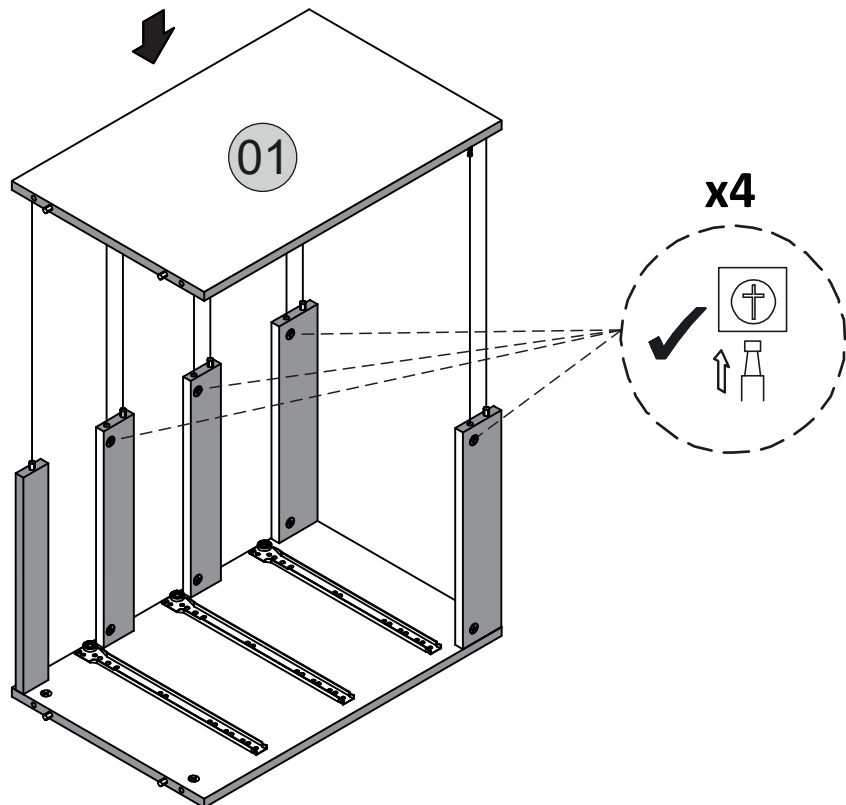
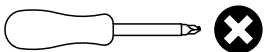

STEP 7

PARTS REQUIRED

09 - TOP PANEL x1

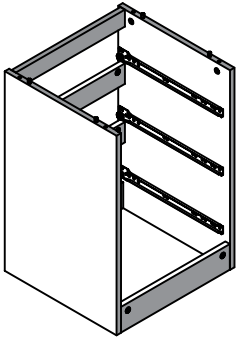

HARDWARE REQUIRED

TOOLS REQUIRED

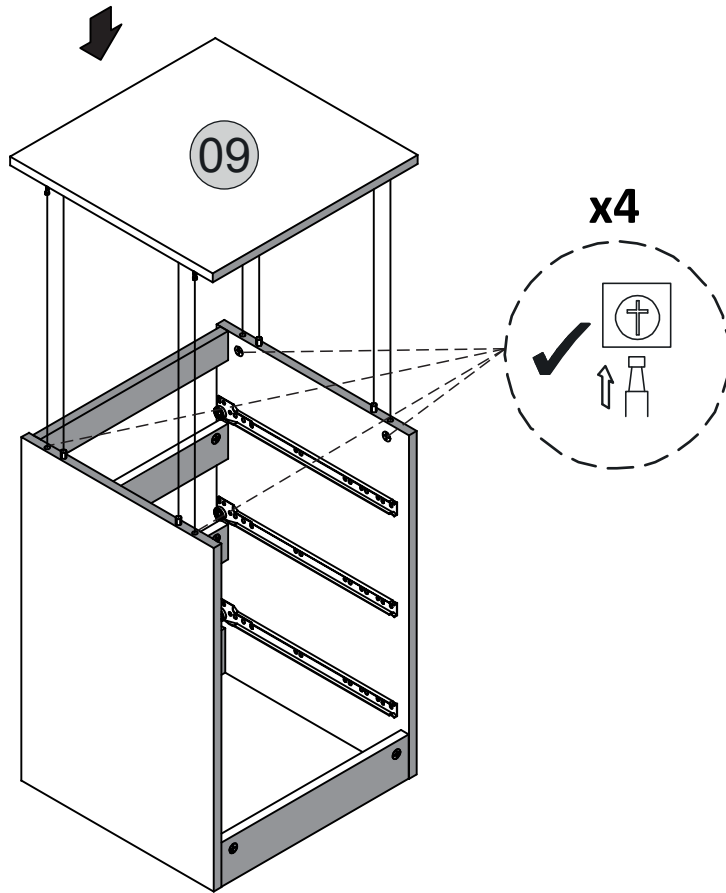
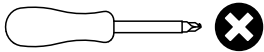

STEP 8

PARTS REQUIRED

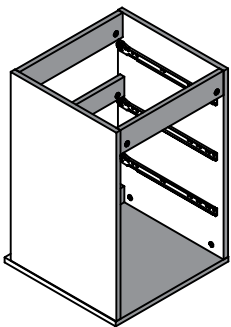

HARDWARE REQUIRED

E  04

G  01

TOOLS REQUIRED

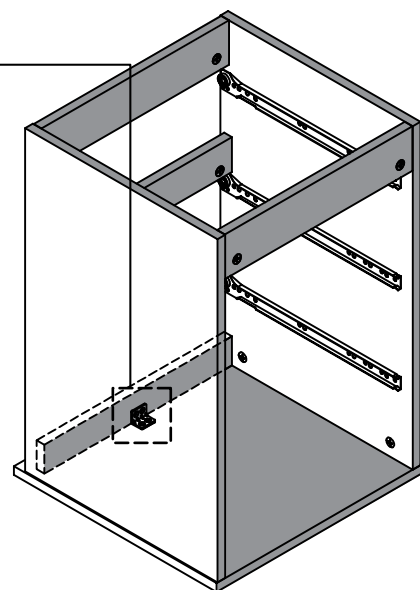
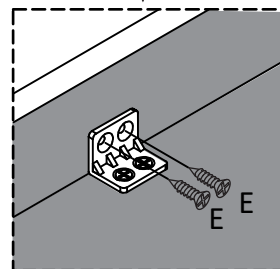
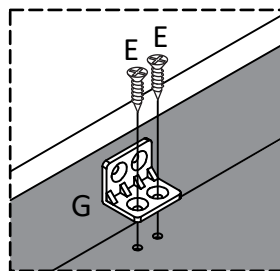
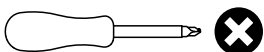

STEP 9

PARTS REQUIRED

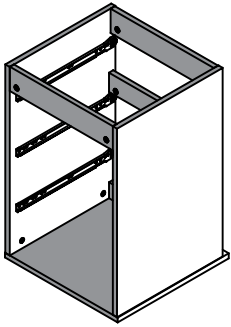

HARDWARE REQUIRED



TOOLS REQUIRED

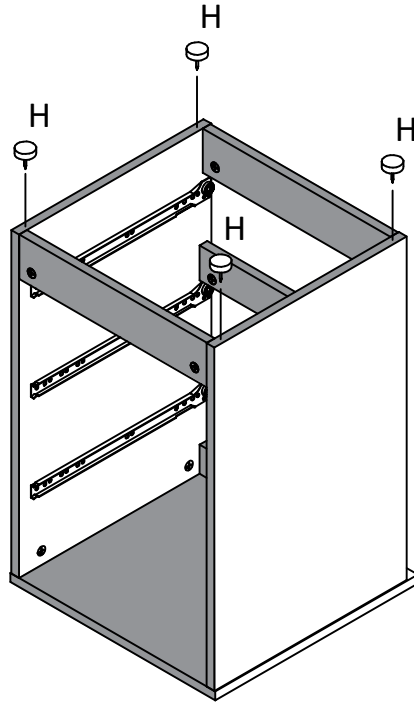
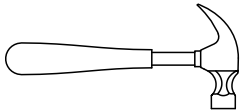

STEP 10

PARTS REQUIRED

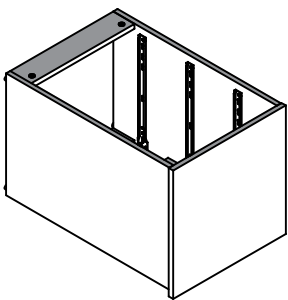

HARDWARE REQUIRED

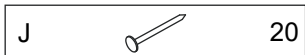

TOOLS REQUIRED

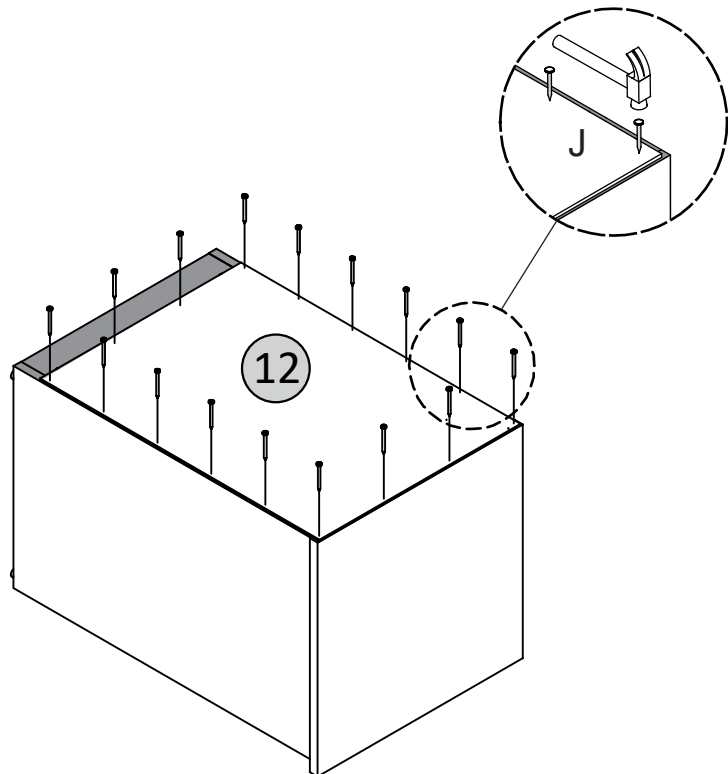
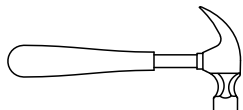

STEP 11

PARTS REQUIRED

03 - DRAWER FRONT x3

04 - DRAWER LEFT PANEL x3

05 - DRAWER RIGHT PANEL x3

HARDWARE REQUIRED

A  06

B  06

C  06

TOOLS REQUIRED

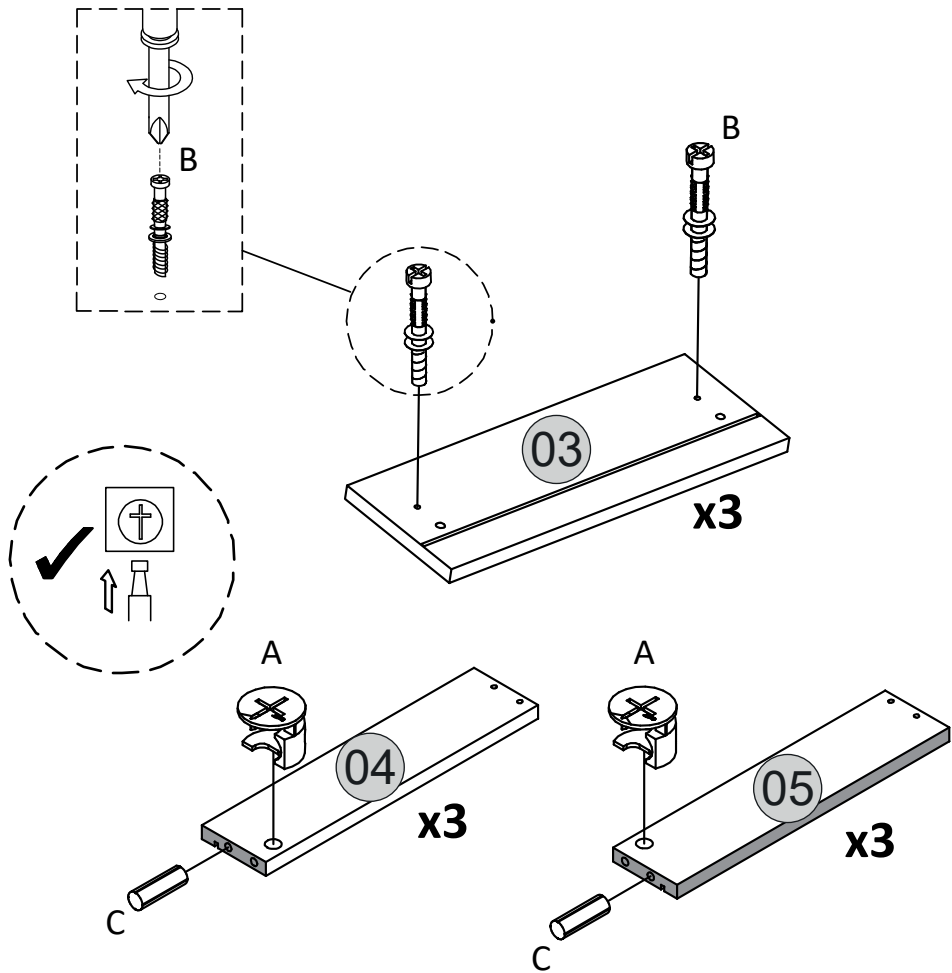
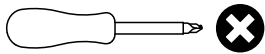

STEP 12

PARTS REQUIRED

04 - DRAWER LEFT PANEL x3

05 - DRAWER RIGHT PANEL x3

10- DRAWER BACK PANEL x3

11- DRAWER BOTTOM PANEL x3

HARDWARE REQUIRED

D  12

TOOLS REQUIRED

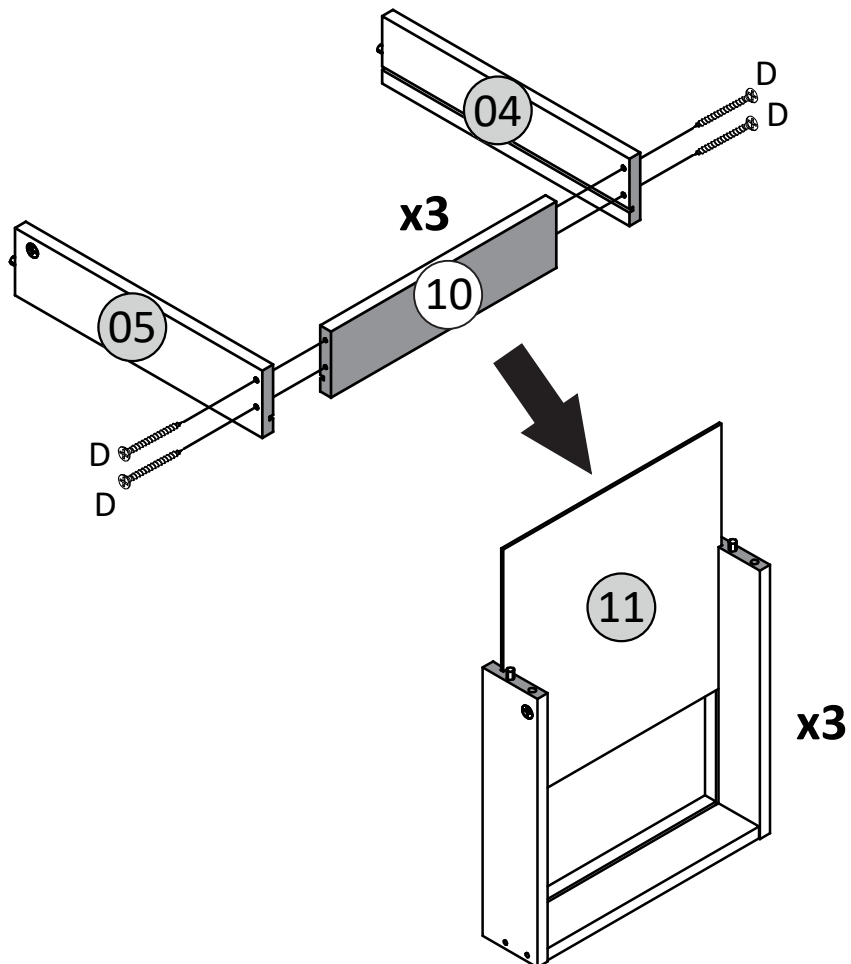
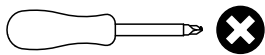

STEP 13

PARTS REQUIRED

03 - DRAWER FRONT x1

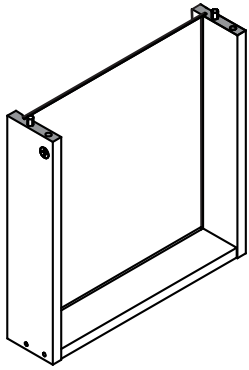

HARDWARE REQUIRED

E  12

F  03

TOOLS REQUIRED

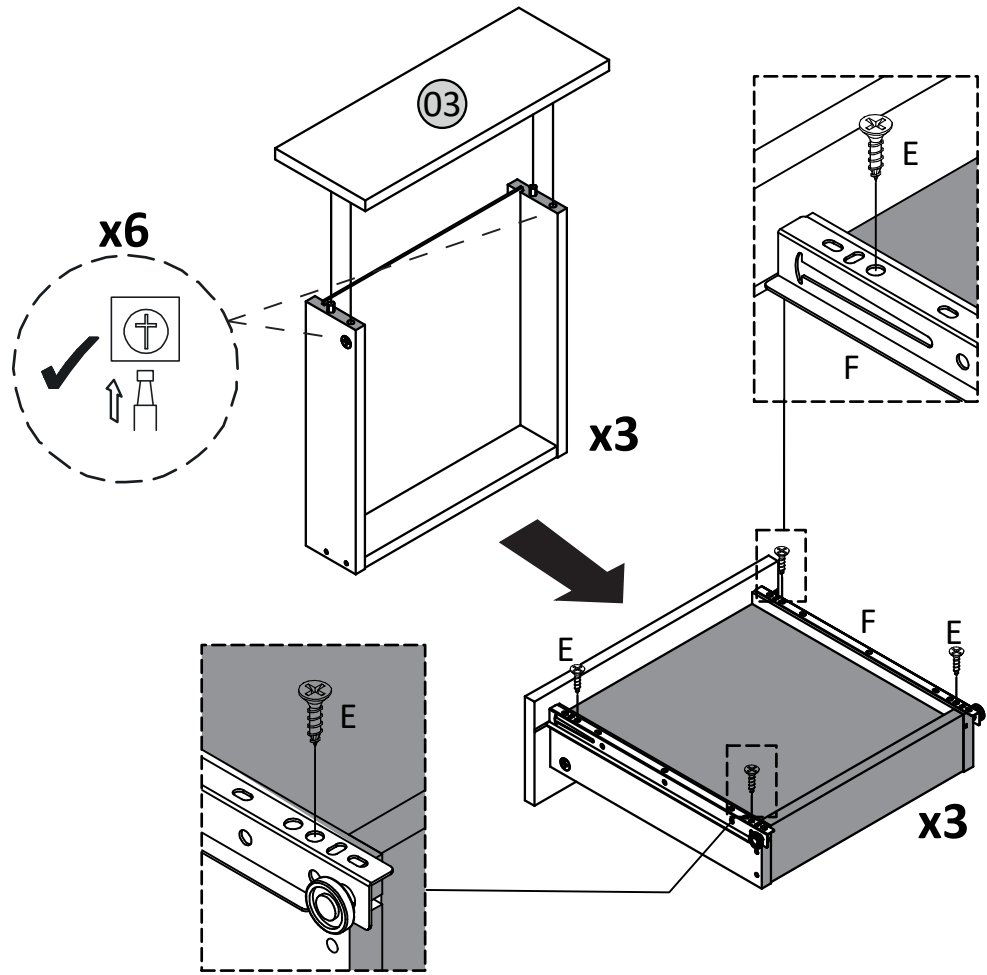
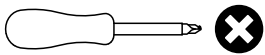

STEP 14

PARTS REQUIRED

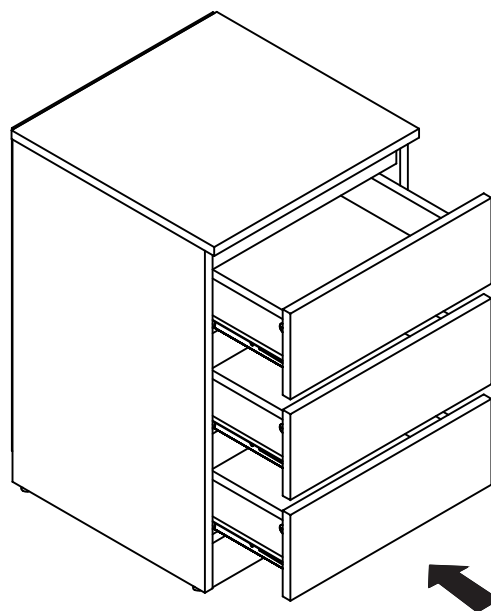
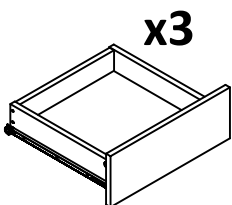
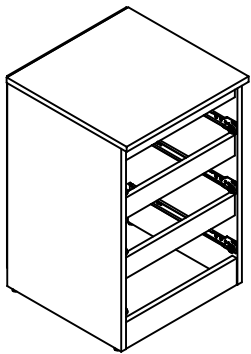

STEP 15

PARTS REQUIRED

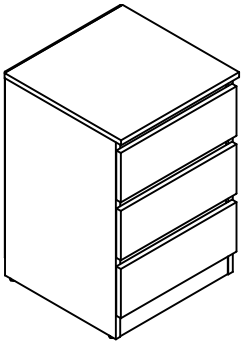

HARDWARE REQUIRED

K  01

TOOLS REQUIRED

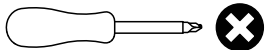

WARNING

Serious or fatal injuries can occur from furniture tipping over. To prevent the furniture from tipping over we recommend that it is permanently fixed to the wall.

Wall fixings are not supplied with this product as different wall materials require different types of fixing devices. Please make sure you use fixings suitable for the walls in your home.

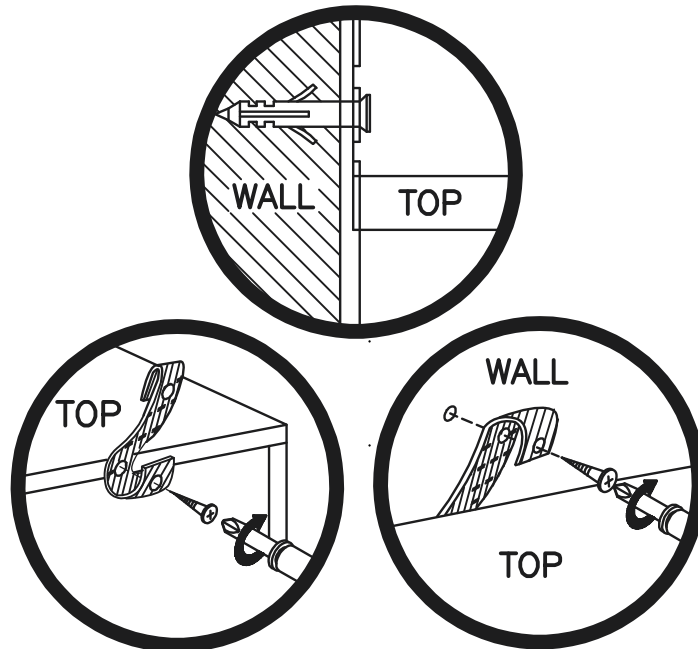

STEP 16

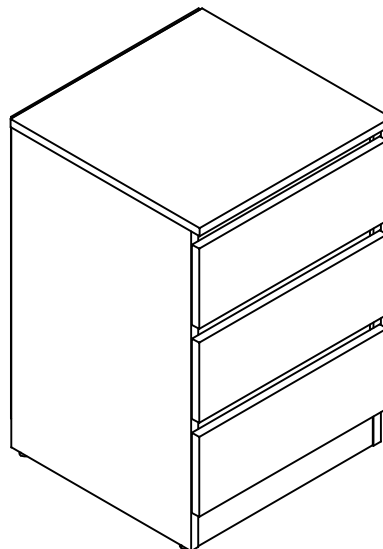

FINISH