

SONOMA OAK EFFECT MALVERN 2 DOOR WARDROBE ASSEMBLY INSTRUCTIONS

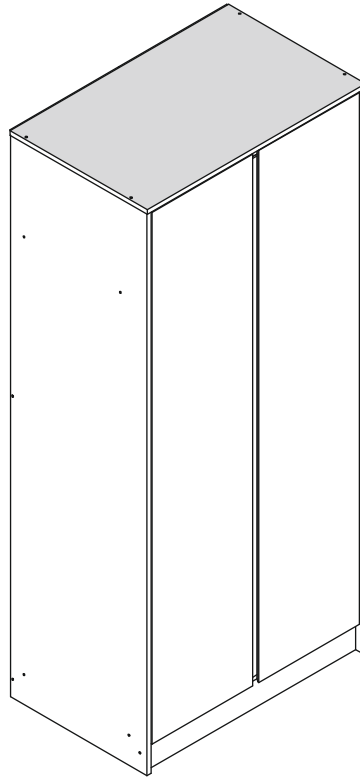

**FOR DOMESTIC USE ONLY
IMPORTANT**

PLEASE READ BEFORE YOU CONTINUE FURTHER

THE PRODUCT YOU HAVE PURCHASED WILL GIVE YOU MANY YEARS OF SERVICE IF YOU FOLLOW THE GUIDELINES FOR ITS SAFE ASSEMBLY AND PERIODIC MAINTENANCE AND CLEANING.

ASSEMBLE ON A SOFT CLEAN SURFACE.

DO NOT USE ANY TOOLS OTHER THAN THOSE SHOWN.

ANY SPANNERS OR ALLEN KEYS REQUIRED ARE INCLUDED WITH THE FITTING KIT.

DO NOT FOR ANY REASON USE A POWER TOOL TO ASSEMBLE THIS PRODUCT. ITS USE WILL INVALIDATE ANY CLAIM YOU MAY HAVE AND COULD MAKE THIS PRODUCT UNSAFE.

DEPENDING ON THE AMOUNT OF USE THIS PRODUCT RECEIVES, IT MAY BE NECESSARY TO TIGHTEN UP THE FIXINGS FROM TIME TO TIME. THIS IS COMPLETELY NORMAL FOR ANY FLAT PACK FURNITURE. DO NOT OVERTIGHTEN FIXINGS.

FOR CLEANING, YOU MAY USE A DAMP CLOTH (NOT WET). DO NOT USE POLISH, DETERGENT OR CHEMICAL CLEANERS.



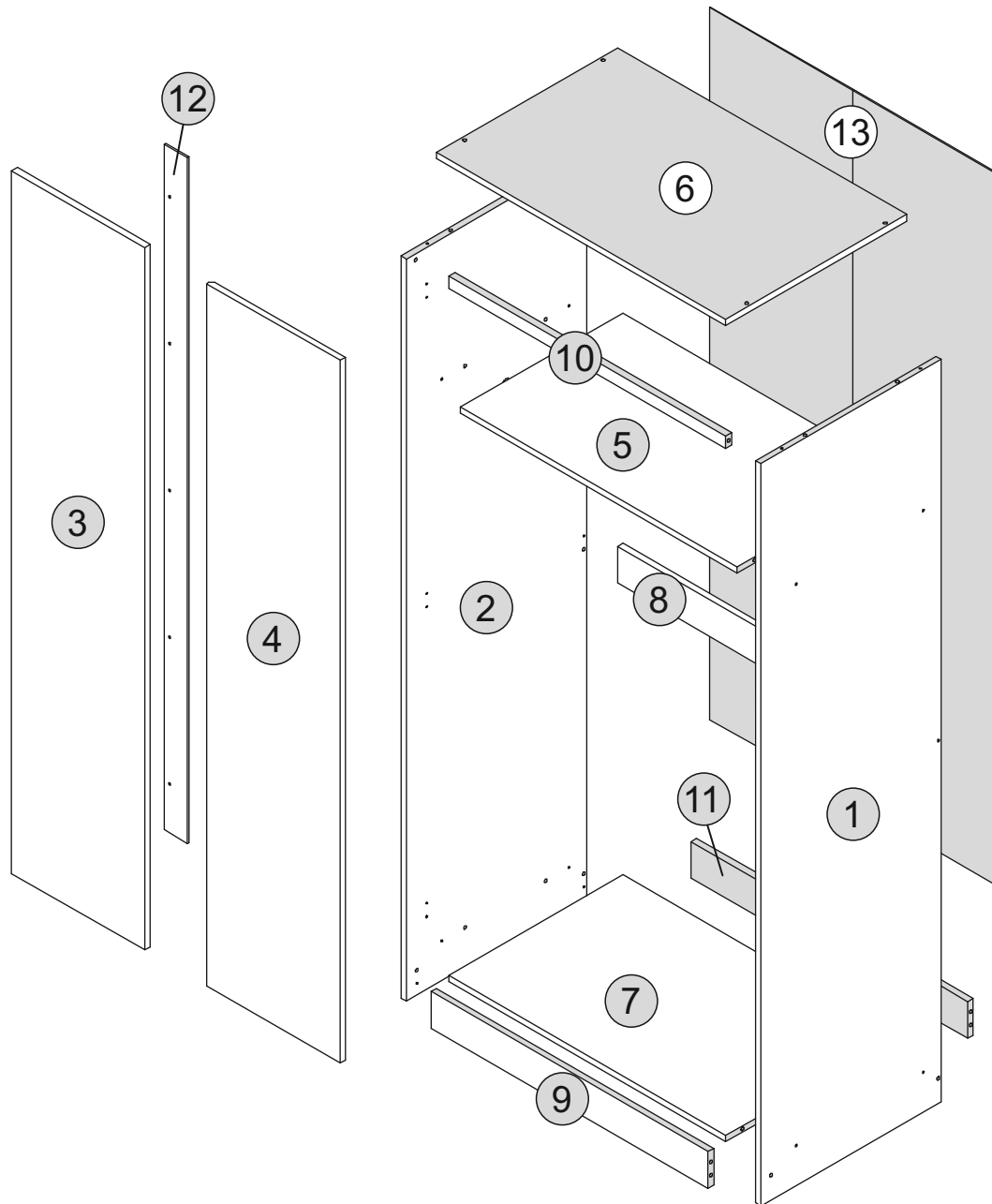







THIS SURFACE OF THIS ITEM IS NOT HEAT RESISTANT. ALWAYS USE A PLACE MAT UNDER HOT OR COLD ITEMS TO PREVENT MARKING.



PART LIST

Part Number	Part Code	Part Description	Quantity	Carton
1	S100-101-171-ZF1-01	Right Side Panel	1	1/2
2	S100-101-171-ZF1-02	Left Side Panel	1	1/2
3	S100-101-171-ZF1-03	Left Door	1	1/2
4	S100-101-171-ZF1-04	Right Door	1	1/2
5	S100-101-171-ZF1-05	Shelf Panel	1	2/2
6	S100-101-171-ZF1-06	Top Panel	1	2/2
7	S100-101-171-ZF1-07	Bottom Panel	1	2/2
8	S100-101-171-ZF1-08	Back Support Panel	1	2/2
9	S100-101-171-ZF1-09	Front Crossbar	1	2/2
10	S100-101-171-ZF1-10	Support Panel	1	2/2
11	S100-101-171-ZF1-11	Back Crossbar	1	2/2
12	S100-101-171-ZF1-12	Door Support	1	1/2
13	S100-101-171-ZF1-13	Back Panel	1	1/2

HARDWARE LIST

No	Part Name		Qty	Carton
A	M8x30mm Wooden Dowel		x20	1
B	M4x45mm Screw		x18	1
C	M3.5x16mm Screw		x35	1
D	PVC L-Bracket		x2	1
E	Screw Cover <small>(Sticker 12mm)</small>		x14	1
F	Plastic Foot		x5	1
G	6/8" Nail		x46	1
H	Hanging Rail (780mm)		x1	1
I	Wall Fixing <small>(4x20mm=1pc)</small>		x1	1
J	End Hinges <small>(M11)-Big</small>		x6	1

TIPS FOR FITTINGS CAM-LOCKS

WHEN FITTING CAM NUT. ENSURE STARTING POSITION IS CORRECT BEFORE YOU INSERT CONNECTING CAM BOLT TURN CLOCKWISE UNTIL SECURE

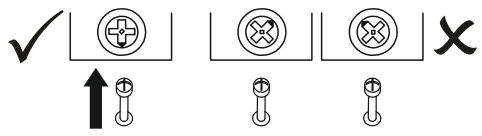

CORRECT
WRONG

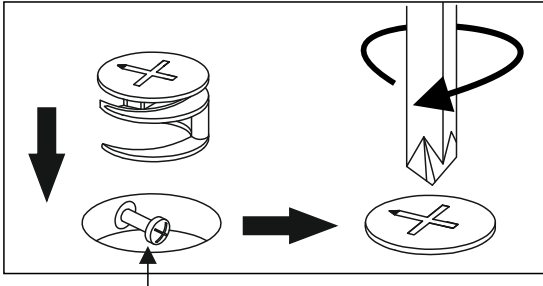

Cam bolt head needs to be in centre

CAMBOLT

Tighten until shoulder in flush with panel. Do not overtighten or undertighten (see example below)

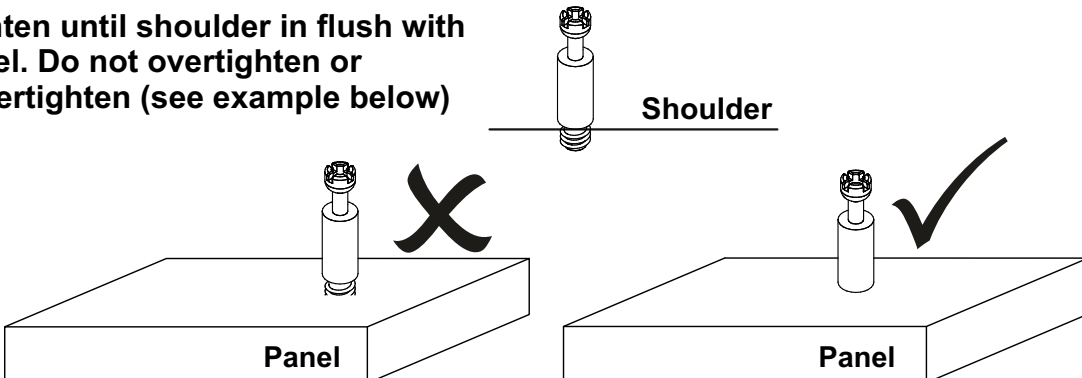

Shoulder



Panel
Panel

STEP 1

PARTS REQUIRED

5 - SHELF PANEL	x1
6 - TOP PANEL	x1
7 - BOTTOM PANEL	x1
8 - BACK SUPPORT PANEL	x1
10 - SUPPORT PANEL	x1
11 - BACK CROSSBAR	x1

HARDWARE REQUIRED

A		14
C		02
D		02

TOOLS REQUIRED

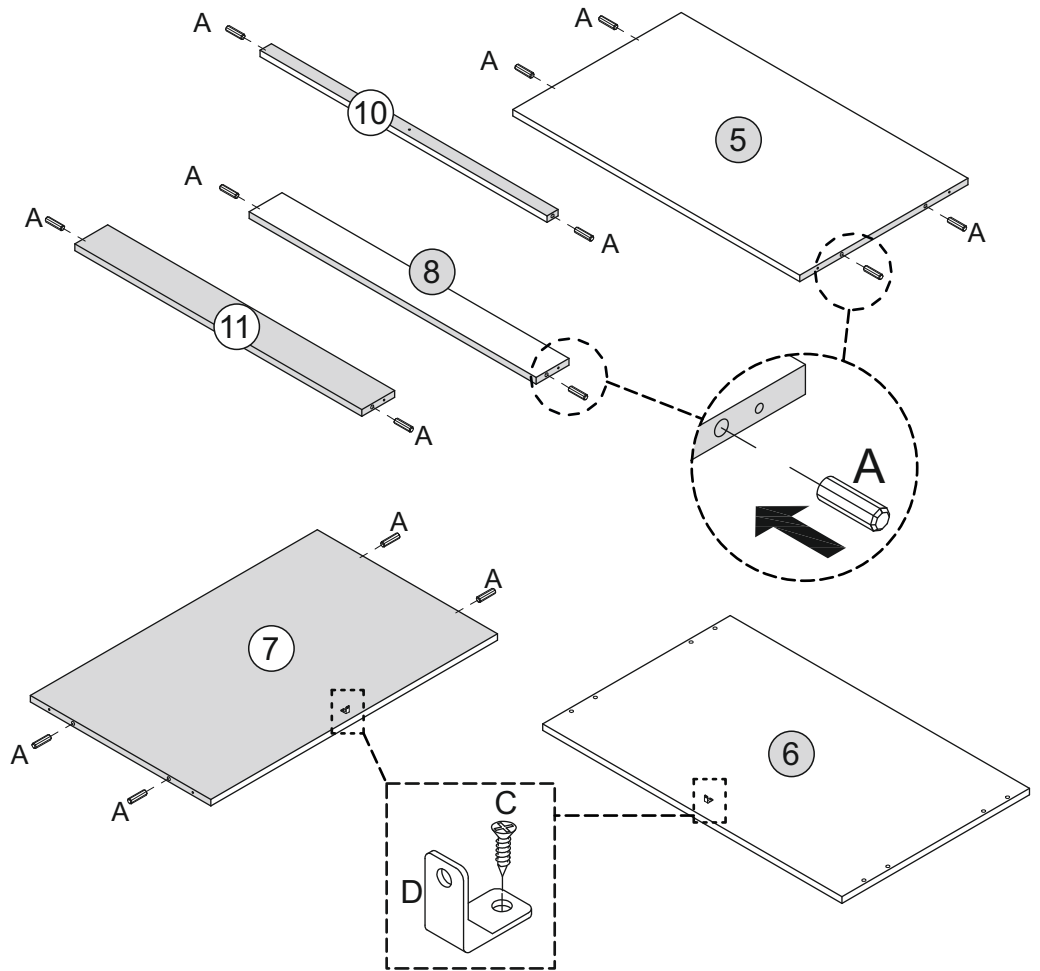
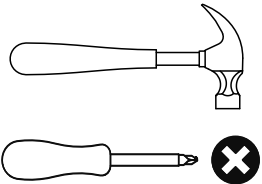



STEP 2

PARTS REQUIRED

1 - RIGHT SIDE PANEL	x1
2 - LEFT SIDE PANEL	x1
9 - FRONT CROSSBAR	x1

HARDWARE REQUIRED

A		06
F		05

TOOLS REQUIRED

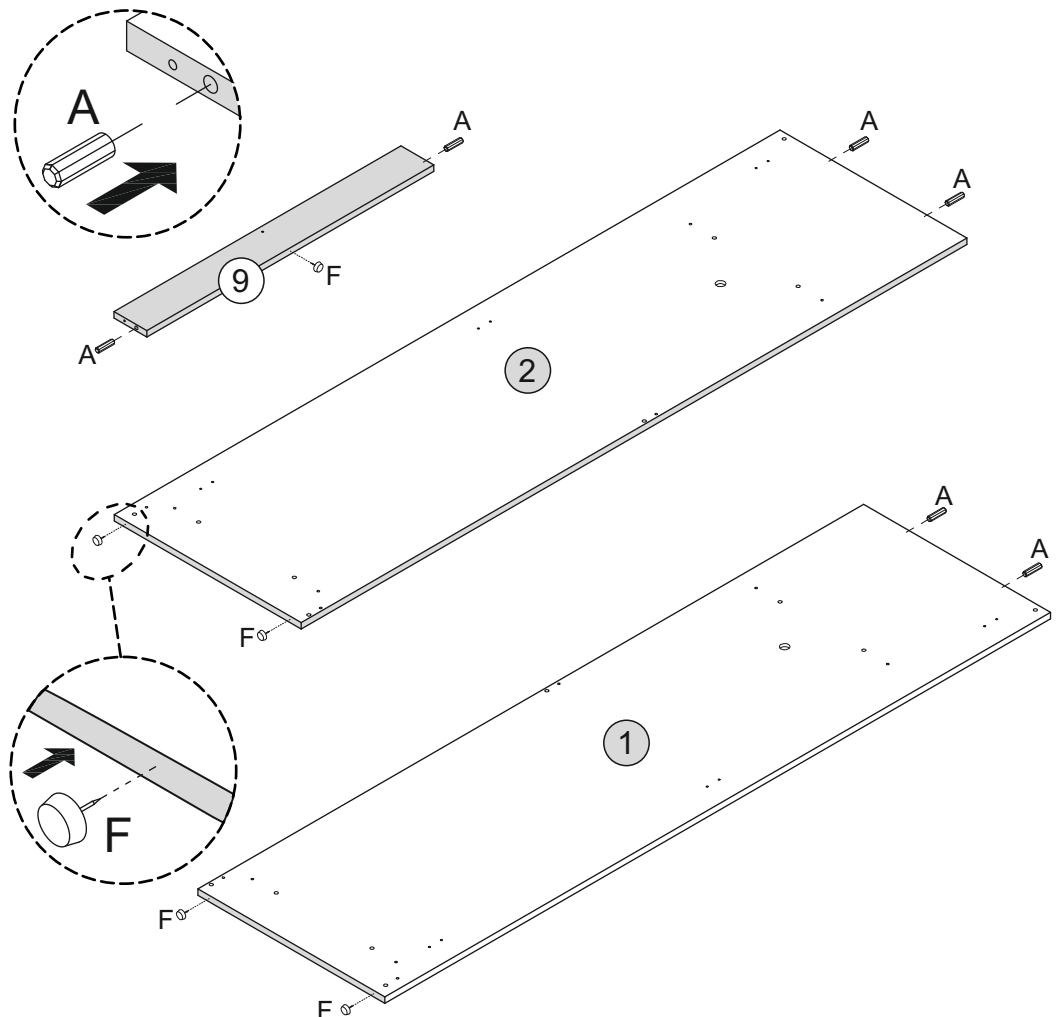
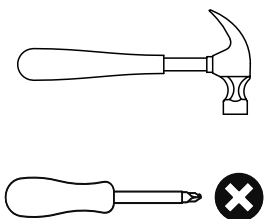



STEP 3

PARTS REQUIRED

3 - LEFT DOOR	x1
4 - RIGHT DOOR	x1
12 - DOOR SUPPORT	x1

HARDWARE REQUIRED

C	 3.5x16mm	17
J		06

TOOLS REQUIRED

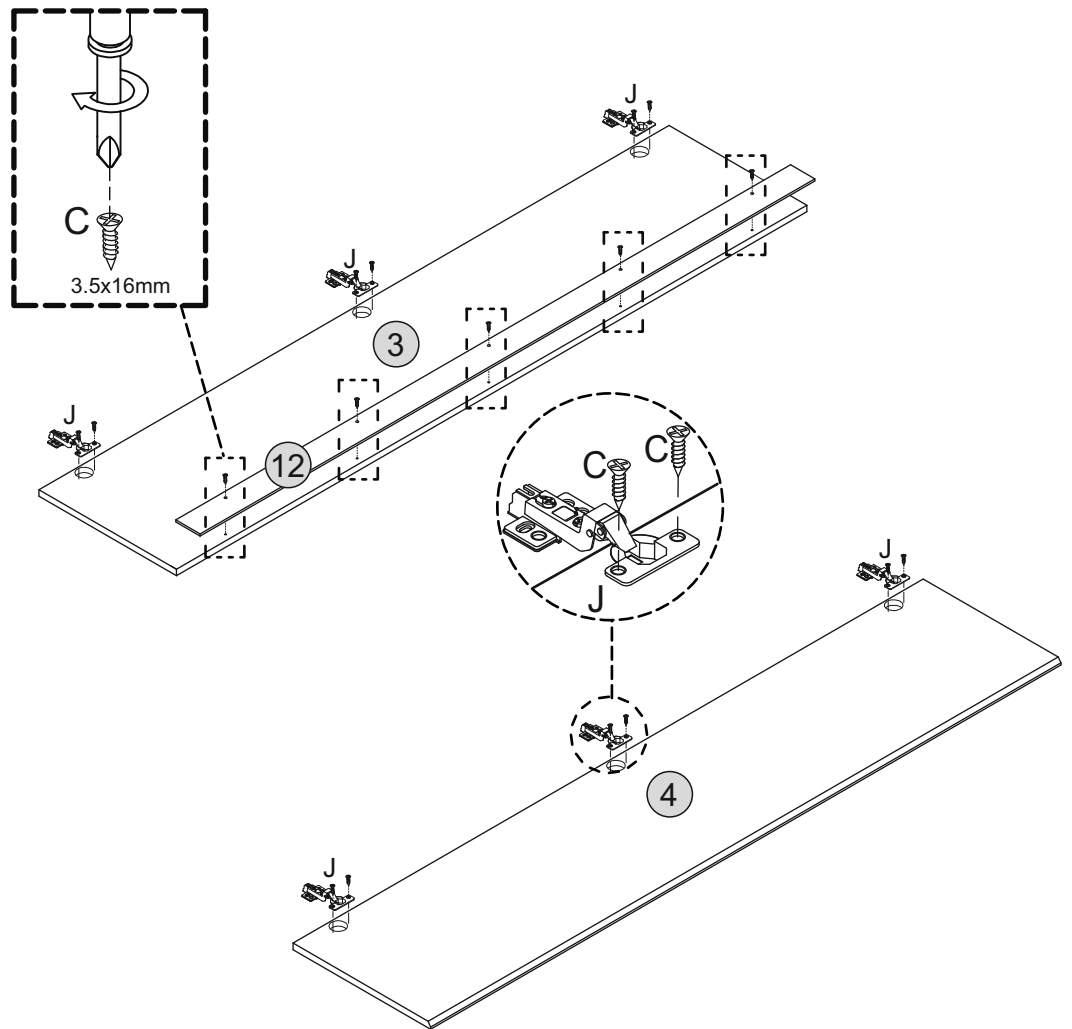
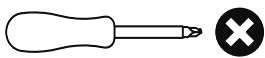



STEP 4

PARTS REQUIRED

1 - RIGHT SIDE PANEL	x1
5 - SHELF PANEL	x1
7 - BOTTOM PANEL	x1
8 - BACK SUPPORT PANEL	x1
9 - FRONT CROSSBAR	x1
11 - BACK CROSSBAR	x1

HARDWARE REQUIRED

B	 4x45mm	07
E		07

TOOLS REQUIRED

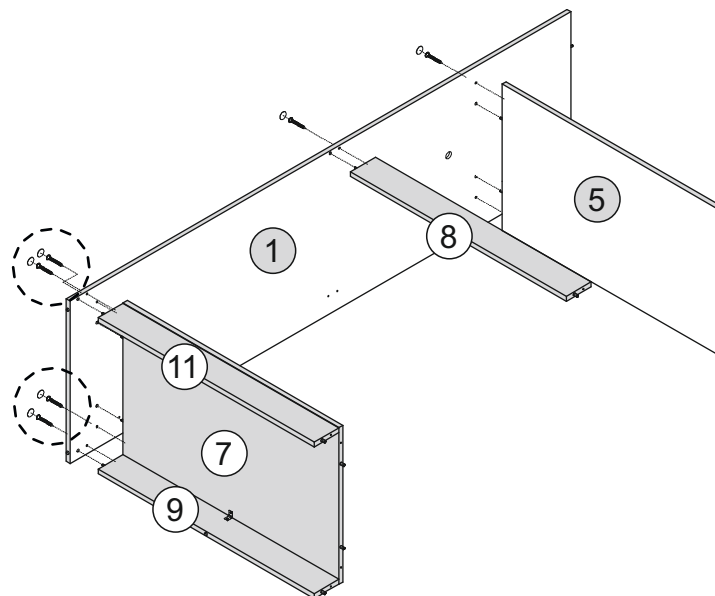
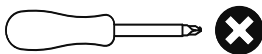

STEP 1

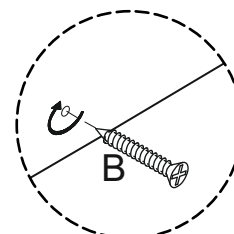

STEP 2

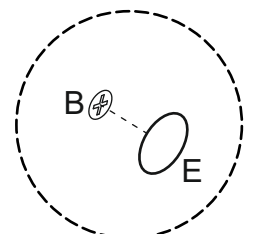

STEP 5

PARTS REQUIRED

2 - LEFT SIDE PANEL x1

10 - SUPPORT PANEL x1

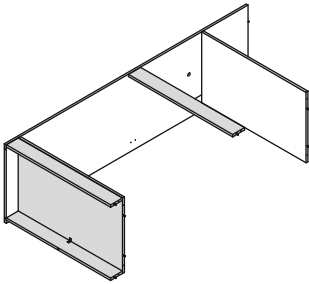

HARDWARE REQUIRED

B  07

E  07

H  01

TOOLS REQUIRED

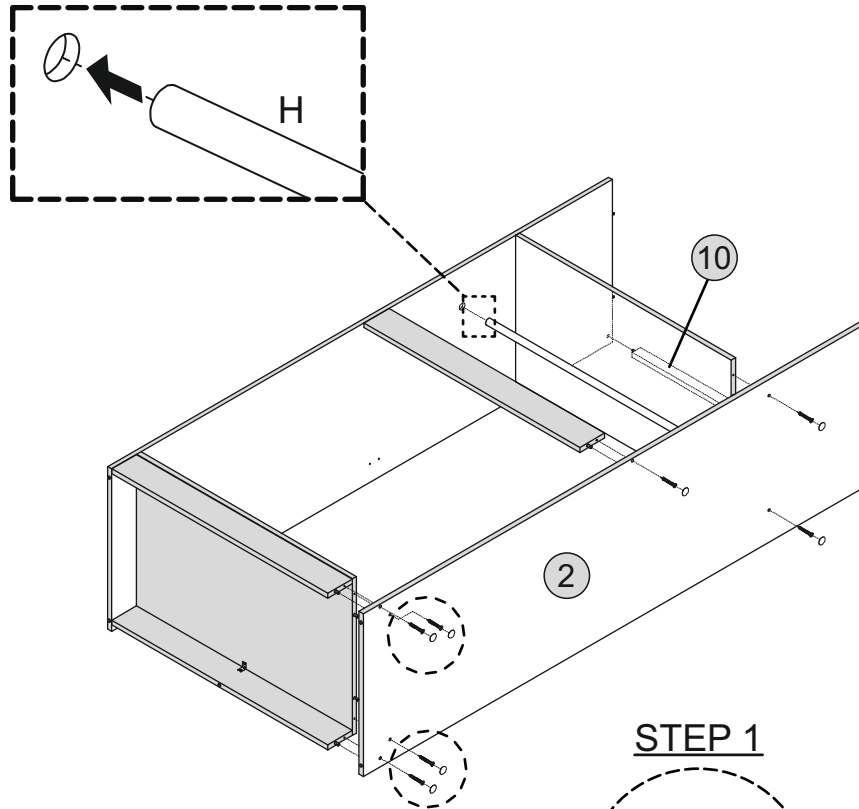
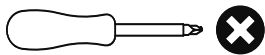

STEP 1

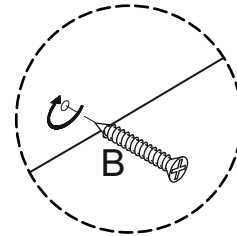

STEP 2

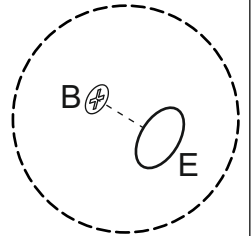

STEP 6

PARTS REQUIRED

6 - TOP PANEL x1

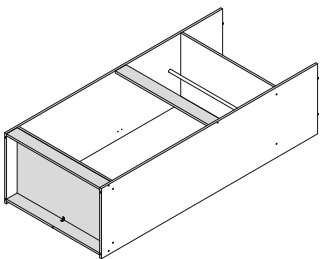

HARDWARE REQUIRED

B  04

TOOLS REQUIRED

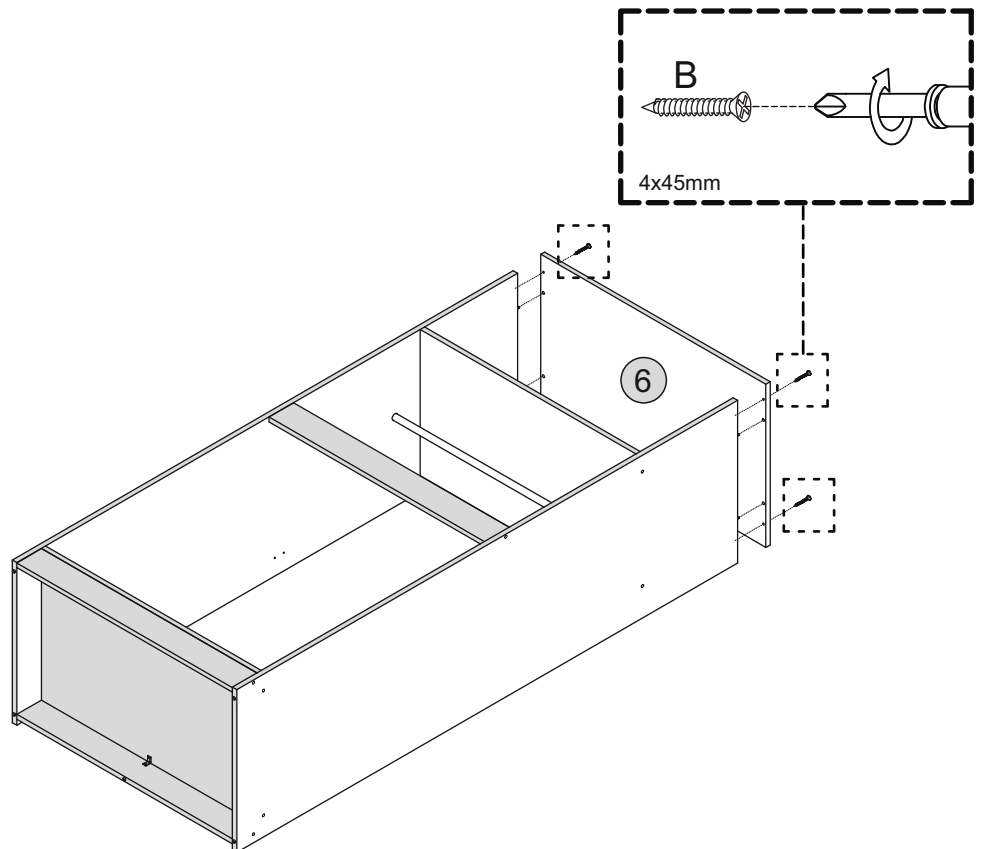
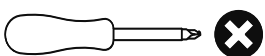

STEP 7

PARTS REQUIRED

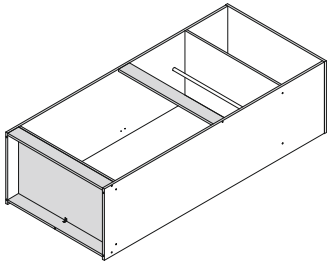

HARDWARE REQUIRED

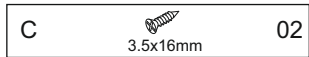

TOOLS REQUIRED

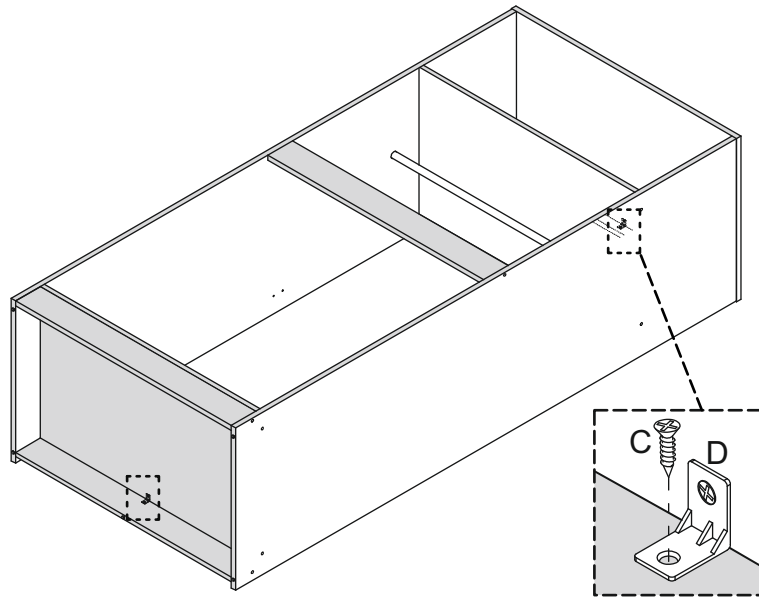
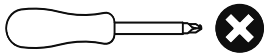

STEP 8

PARTS REQUIRED

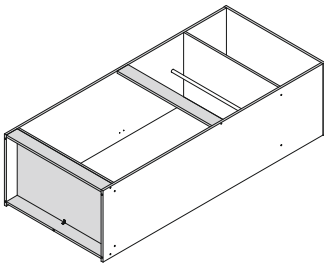

HARDWARE REQUIRED

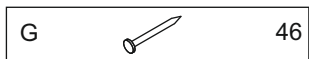

TOOLS REQUIRED

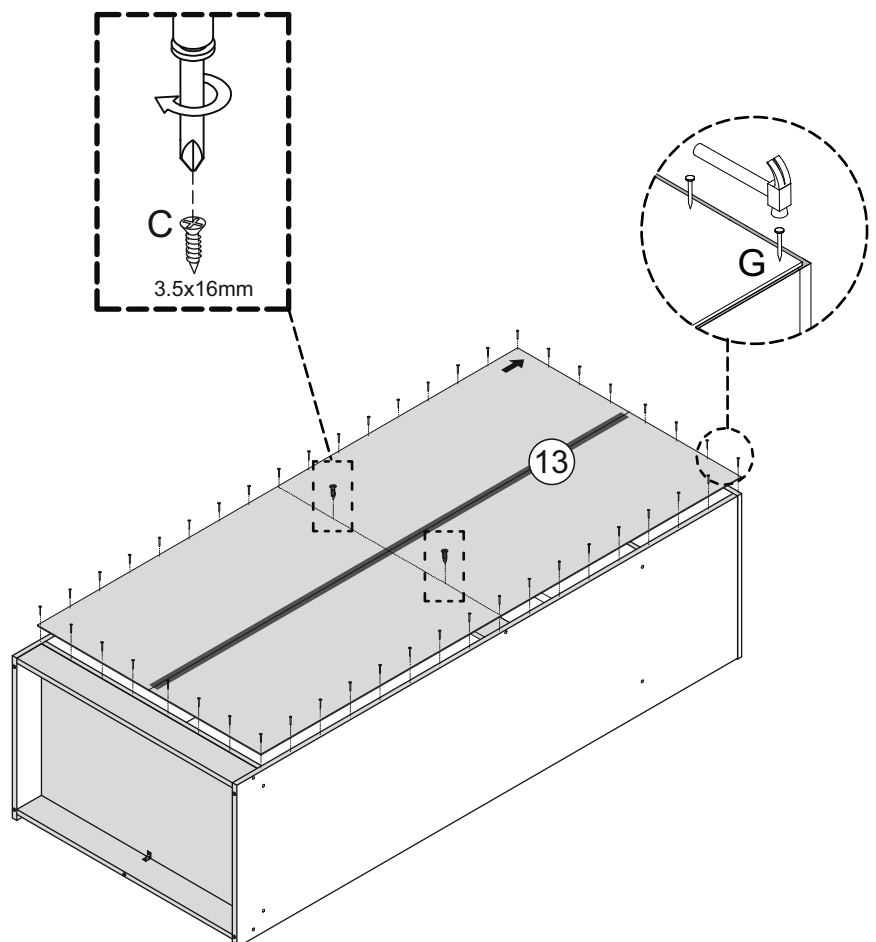
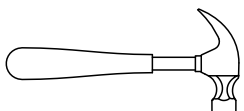
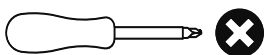

STEP 9

PARTS REQUIRED

3 - LEFT DOOR x1

4 - RIGHT DOOR x1

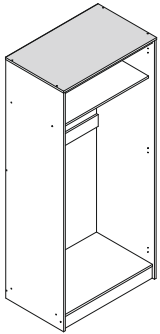

HARDWARE REQUIRED

C 3.5x16mm 12

TOOLS REQUIRED

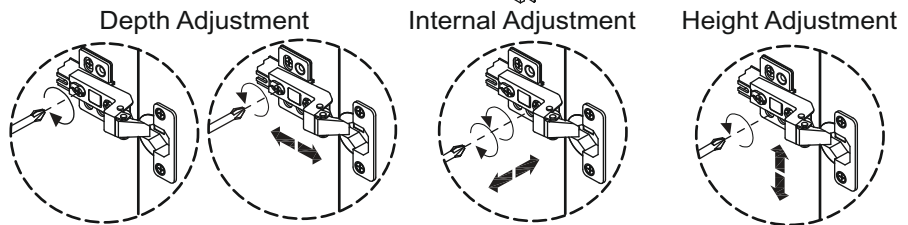
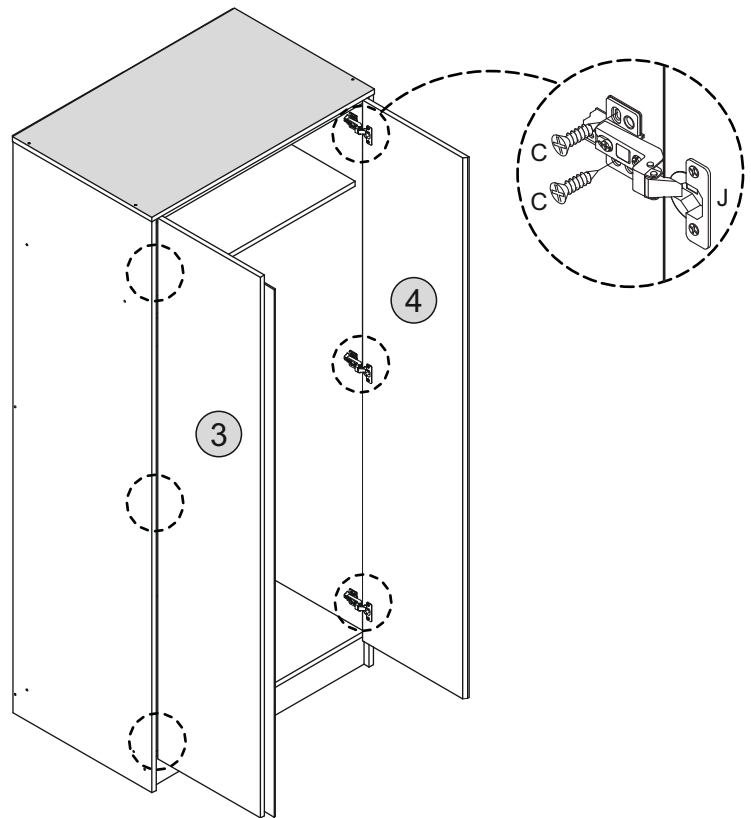
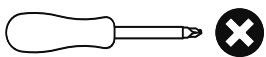

STEP 10

PARTS REQUIRED

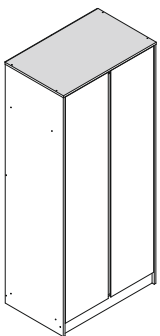

HARDWARE REQUIRED

I 01

TOOLS REQUIRED

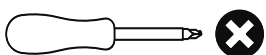

WARNING

Serious or fatal injuries can occur from furniture tipping over. To prevent the furniture from tipping over we recommend that it is permanently fixed to the wall.

Wall fixings are not supplied with this product as different wall materials require different types of fixing devices. Please make sure you use fixings suitable for the walls in your home.

