

# NEVADA 1 DOOR 1 DRAWER WARDROBE ASSEMBLY INSTRUCTIONS

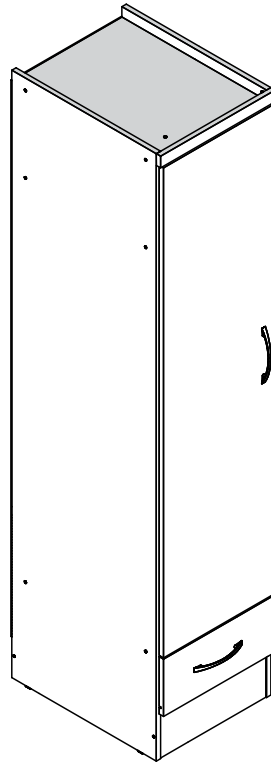

## IMPORTANT FOR DOMESTIC USE ONLY

PLEASE READ BEFORE YOU CONTINUE FURTHER

## CARE AND MAINTENANCE

After unpacking this product please keep the original packaging in case it needs to be returned for any reason.

- Please ensure all fittings and parts are present before commencing with assembly.
- Never drag or push products as this could cause damage to the joints making it inferior.
- We strongly recommend that you keep children away from your work area.
- We recommend that you lay a blanket or sheet on the floor to avoid damage to both your floor and the product.
- Assemble this product as close to its final position as possible.
- Do not place this product next to a radiator or in direct sunlight.
- Do not drag or push items across your high gloss furniture as this may cause the surface to scratch
- Wood is a natural product and may expand if subjected to damp and may shrink or crack if subjected to heat. Therefore it is recommended that room temperature is maintained, with no sudden temperature fluctuations.
- Make sure any spillage is wiped off immediately.
- Do not place hot or chilled items directly on to the surface, use a place mat or marking will occur.
- For general cleaning use a soft cotton or micro fibre cloth, and do not use detergents of any kind.
- From time to time it may be necessary to tighten fittings, regular inspections should be carried out.
- Do not place on a wet or damp floor as staining may occur to your floor.

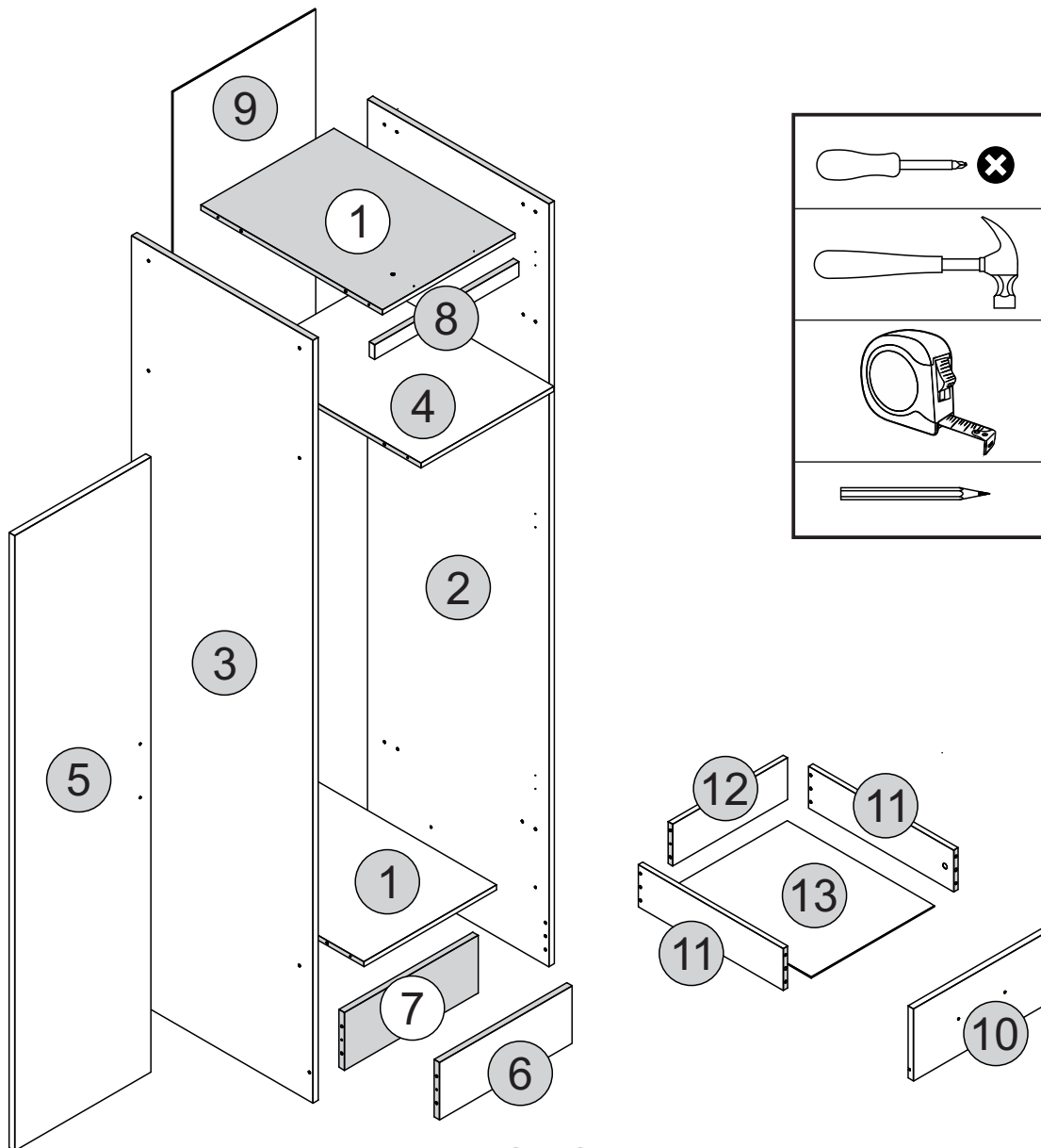

## PARTS LIST







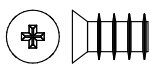
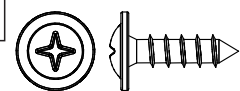
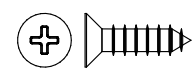
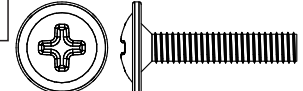
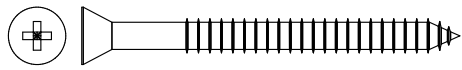

***Please Note:***

The below parts have all been stamped with the part number to help identify them during assembly.

Part Number	Part Description	Quantity	Carton
01	Base-Top Panel	2	1/1
02	Right Side Panel	1	1/1
03	Left Side Panel	1	1/1
04	Shelf	1	1/1
05	Door	1	1/1
06	Front Baseboard	1	1/1
07	Back Baseboard	1	1/1
08	Frame	1	1/1
09	Back Panel	1	1/1
10	Drawer Front	1	1/1
11	Drawer Side	2	1/1
12	Drawer Back Panel	1	1/1
13	Drawer Bottom	1	1/1

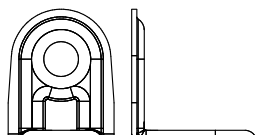
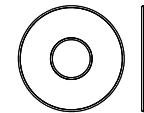
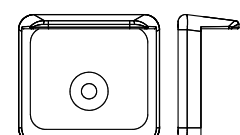
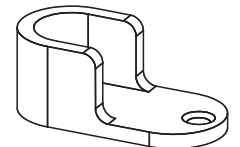
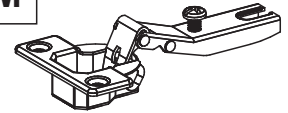
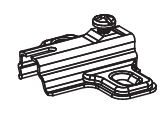
# FITTINGS LIST

SEC/SH/02/23/CA2

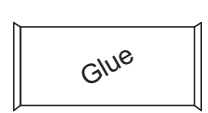
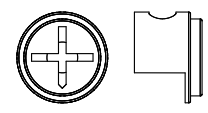
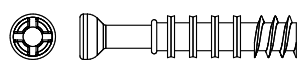
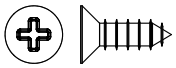
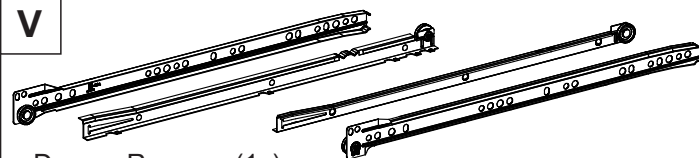
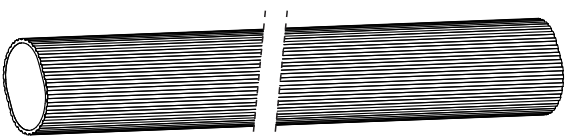
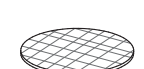
<b>A</b>  Flat Head Screw 1/+ Ø6,0 x 10mm (4x)	<b>B</b>  Flan Head Screw 2/+ Ø4,0 x 14mm (3x)	<b>C</b>  Flat Head Screw 2/+ Ø4,0 x 14mm (22x)	<b>D</b>  Flan Head Screw 1/+ Ø4,0 x 22mm (4x)
<b>E</b>  Flat Head Screw 2/+ Ø4,0 x 50mm (18x)	<b>F</b>  Dowel Ø6,0 x 30mm (28x)	<b>G</b>  Nail 10 x 10 (46x)	
<b>H</b>  Flan Head Screw 1/+ Ø3,5 x 30mm (1x)	<b>I</b>  'L' Metallic Support (4x)	<b>J</b>  Washer (2x)	<b>K</b>  Plastic Foot (4x)
<b>L</b>  Hanging Rail Support (2x)	<b>M</b>  Hinge (3x)	<b>N</b>  Hinge Plate (3x)	<b>O</b>  Strap (1x)
<b>P</b>  Handle (2x)	<b>Q</b>  Hole Plugs (16x)	<b>R</b>  Glue (1x)	<b>S</b>  Cam Nut (2x)
<b>T</b>  Cam Bolt (2x)	<b>U</b>  Flat Head Screw 2/+ Ø4,0 x 12mm (8x)	<b>V</b>  Drawer Runners (1x)	
<b>X</b>  Hanging Rail (1x)	<b>Y</b>  Hole Plugs (2x)		

## TIPS FOR FITTINGS CAM-LOCKS

WHEN FITTING CAM NUT. ENSURE STARTING POSITION IS CORRECT BEFORE YOU INSERT CONNECTING CAM BOLT TURN CLOCKWISE UNTIL SECURE

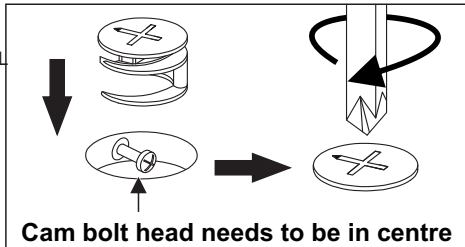
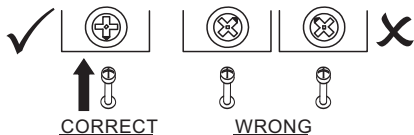

**CAMBOLT**  
 Tighten until shoulder is flush with panel. Do not overtighten or undertighten (see example beside)

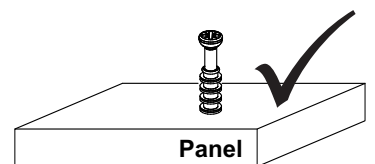
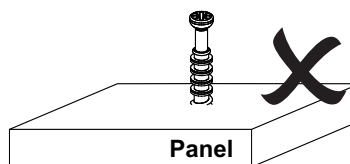
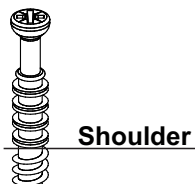



# STEP 1

## PARTS REQUIRED

3 - LEFT SIDE PANEL x1

## HARDWARE REQUIRED

A  02  
Ø6,0 x 10mm

G  02  
10 x 10

K  02

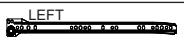
V  01  
LEFT

## TOOLS REQUIRED

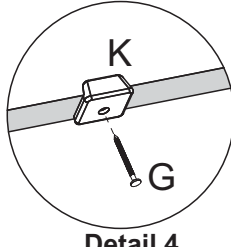
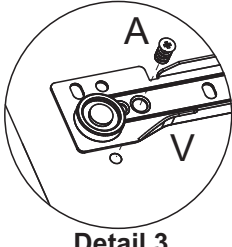
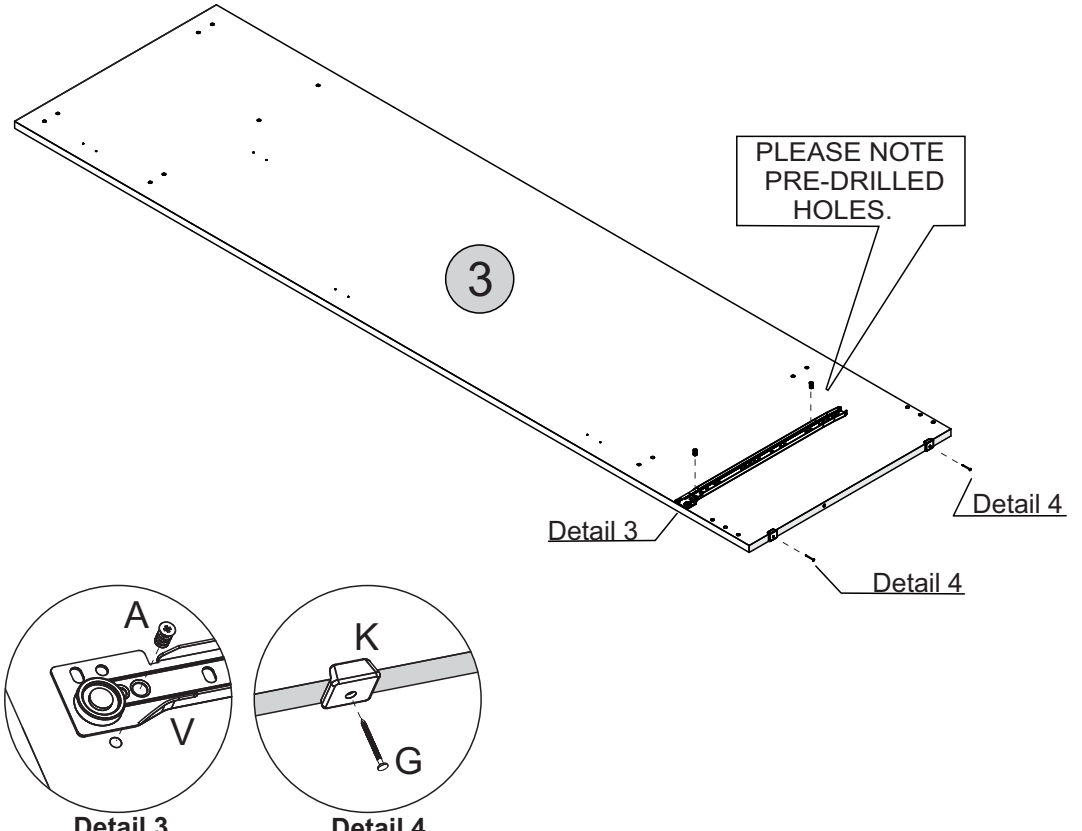
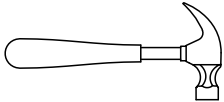
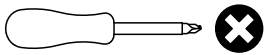



# STEP 2

## PARTS REQUIRED

2 - RIGHT SIDE PANEL x1

## HARDWARE REQUIRED

A  02  
Ø6,0 x 10mm

G  02  
10 x 10

K  02

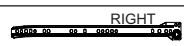
V  01  
RIGHT

## TOOLS REQUIRED

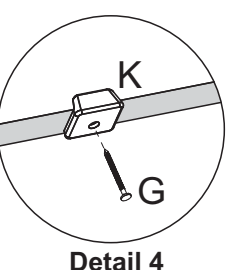
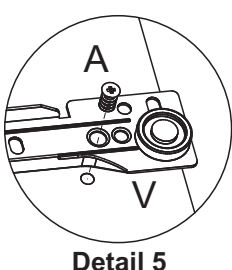
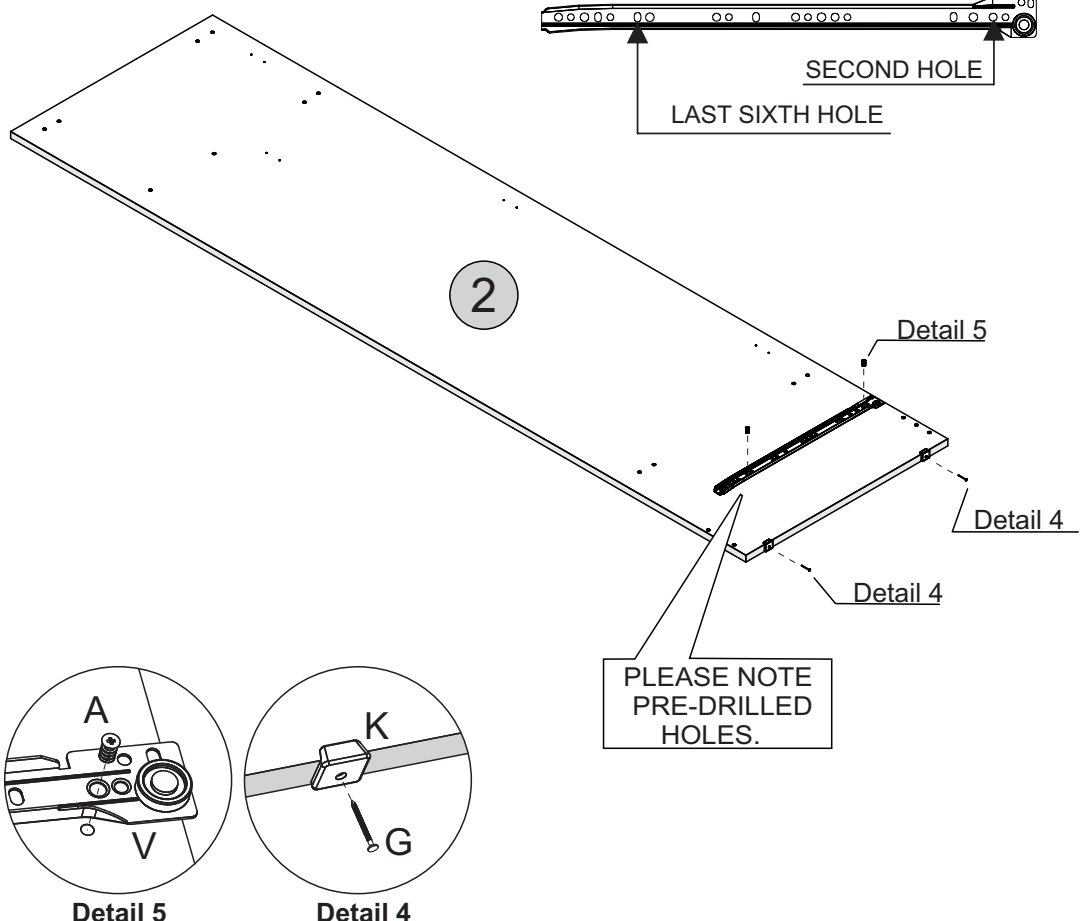
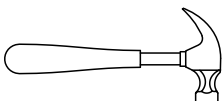
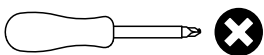



# STEP 3

## PARTS REQUIRED

3 - LEFT SIDE PANEL x1

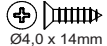
## HARDWARE REQUIRED

C  08  
Ø4,0 x 14mm

L  01

N  03

## TOOLS REQUIRED

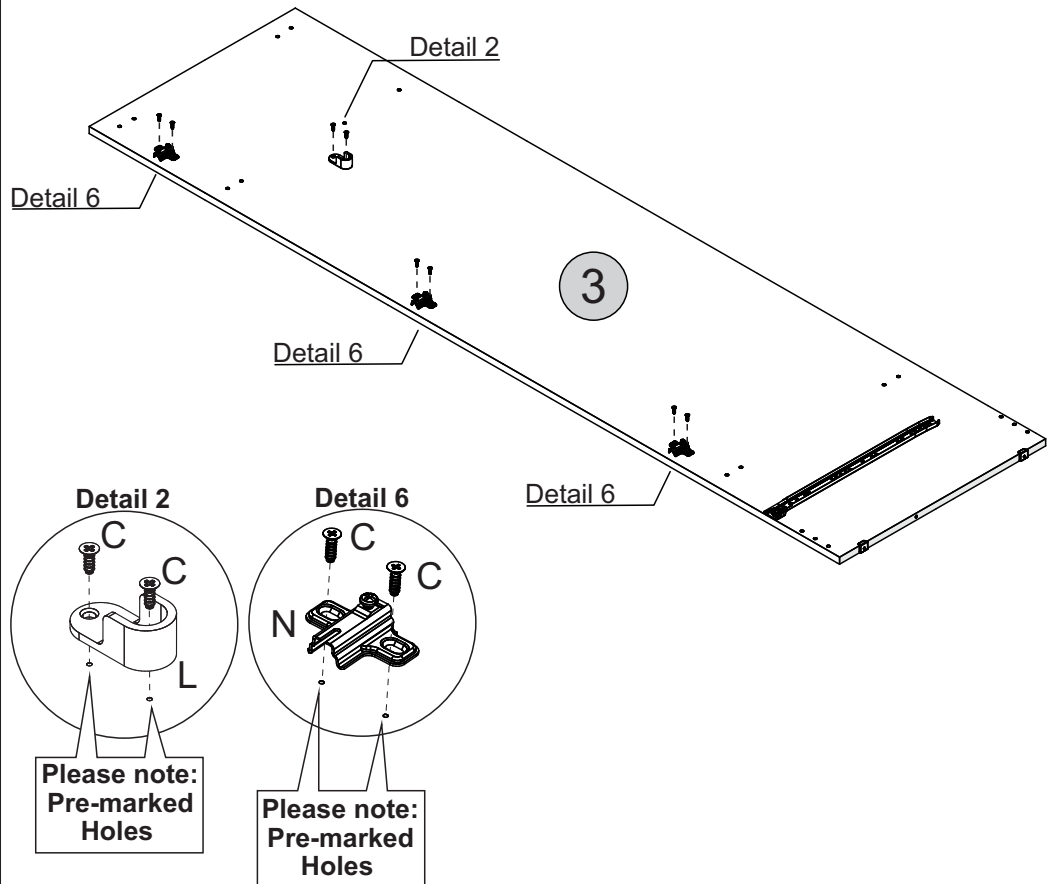
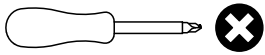

# STEP 4

## PARTS REQUIRED

2 - RIGHT SIDE PANEL x1

## HARDWARE REQUIRED

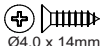
C  02  
Ø4,0 x 14mm

L  01

## TOOLS REQUIRED

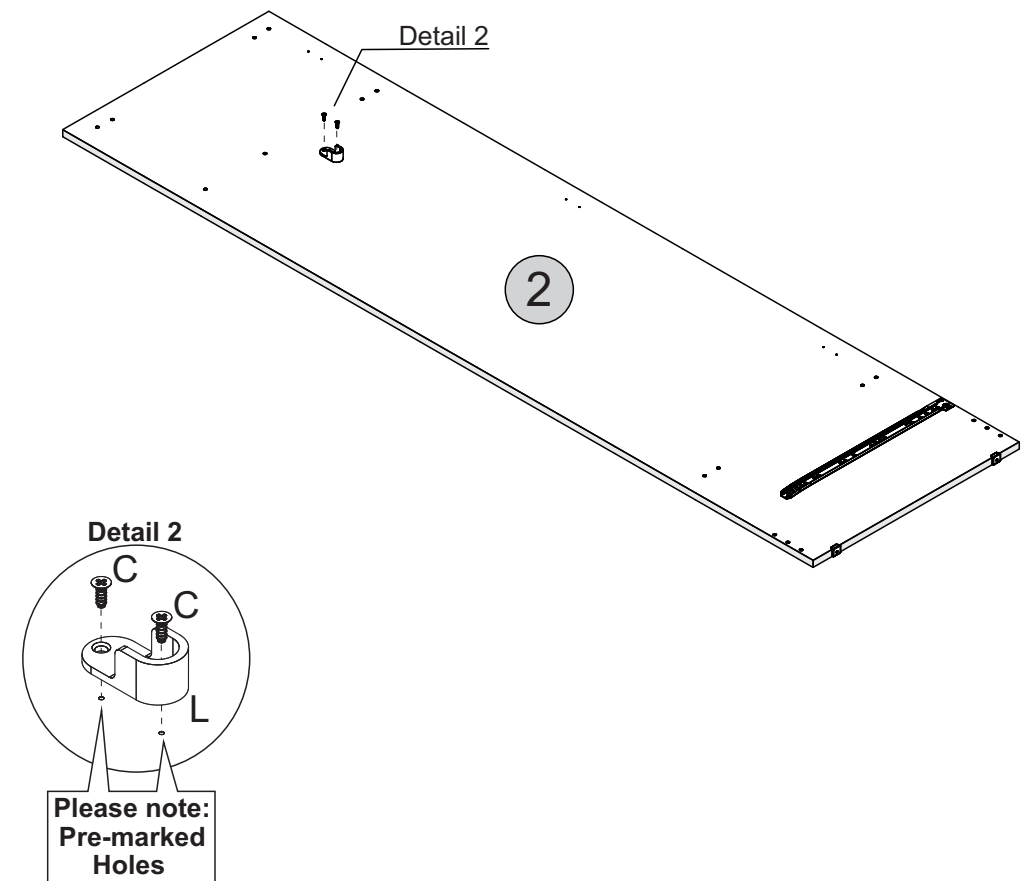
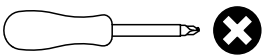





# STEP 5

## PARTS REQUIRED

1A - TOP PANEL	x1
1B - BASE PANEL	x1
4 - SHELF	x1

## HARDWARE REQUIRED

F	 Ø6,0 x 30mm	12
I		02
R	 Glue	01
U	 Ø4,0 x 12mm	02

## TOOLS REQUIRED

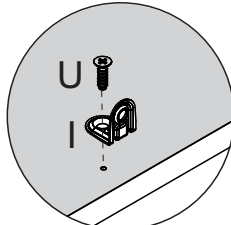
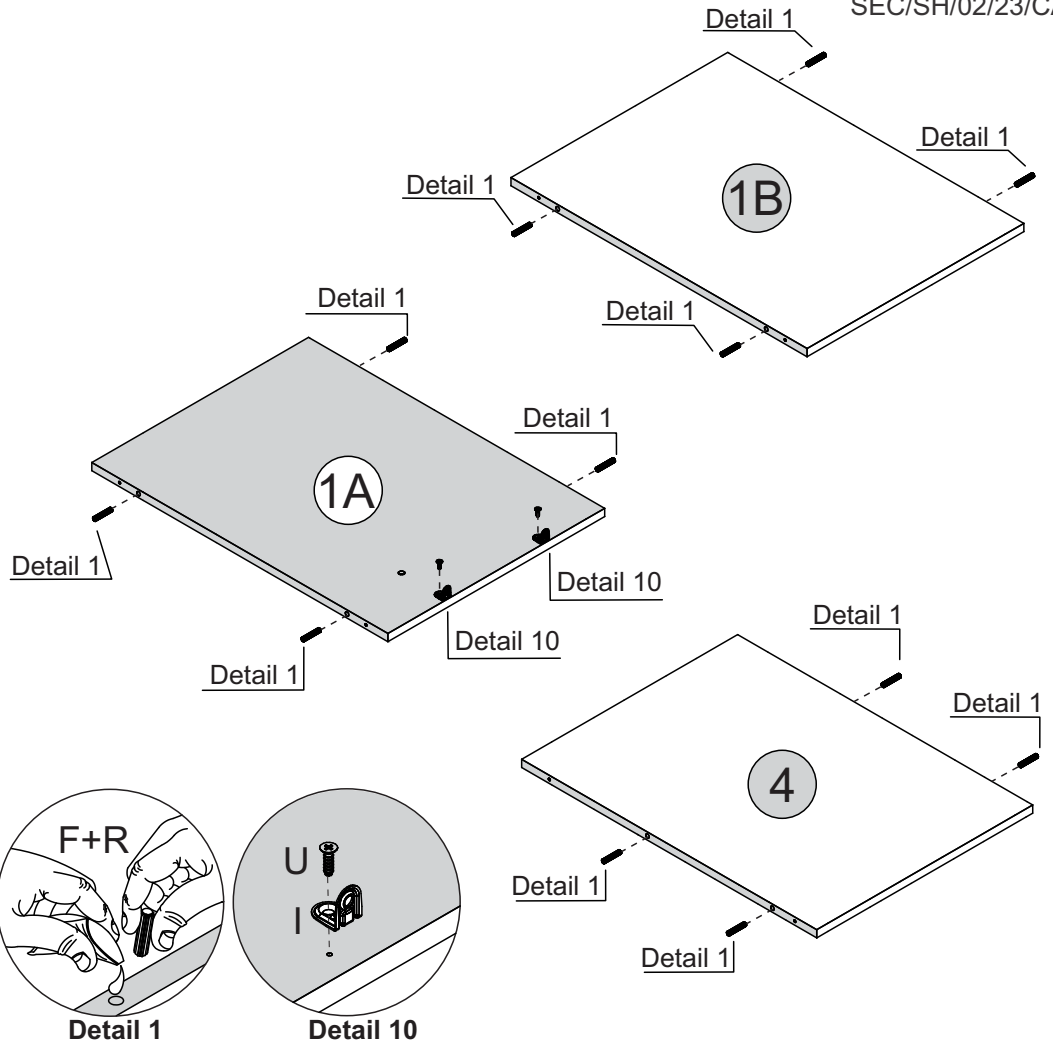
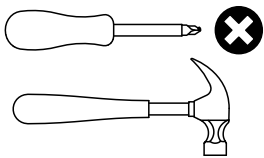

Detail 1



Detail 10

# STEP 6

## PARTS REQUIRED

6 - FRONT BASEBOARD	x1
7 - BACK BASEBOARD	x1

## HARDWARE REQUIRED

F	 Ø6,0 x 30mm	08
R	 Glue	01

## TOOLS REQUIRED

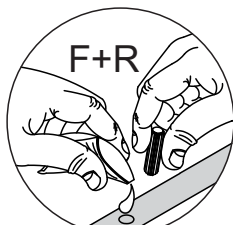
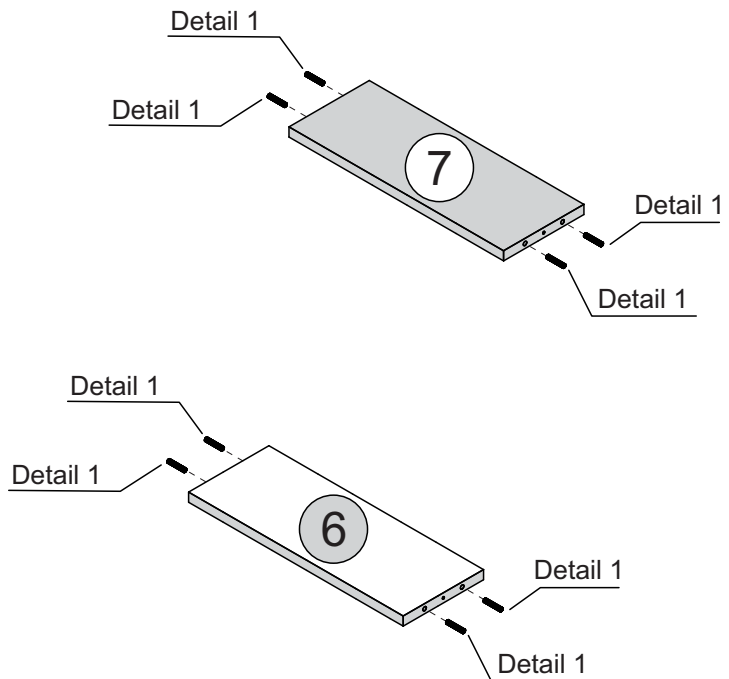
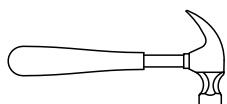



Detail 1

# STEP 7

## PARTS REQUIRED

- 1A - TOP PANEL x1
- 1B - BASE PANEL x1
- 2 - RIGHT SIDE PANEL x1
- 4 - SHELF x1

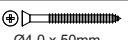
## HARDWARE REQUIRED

- E  06  
Ø4,0 x 50mm
- R  01

## TOOLS REQUIRED

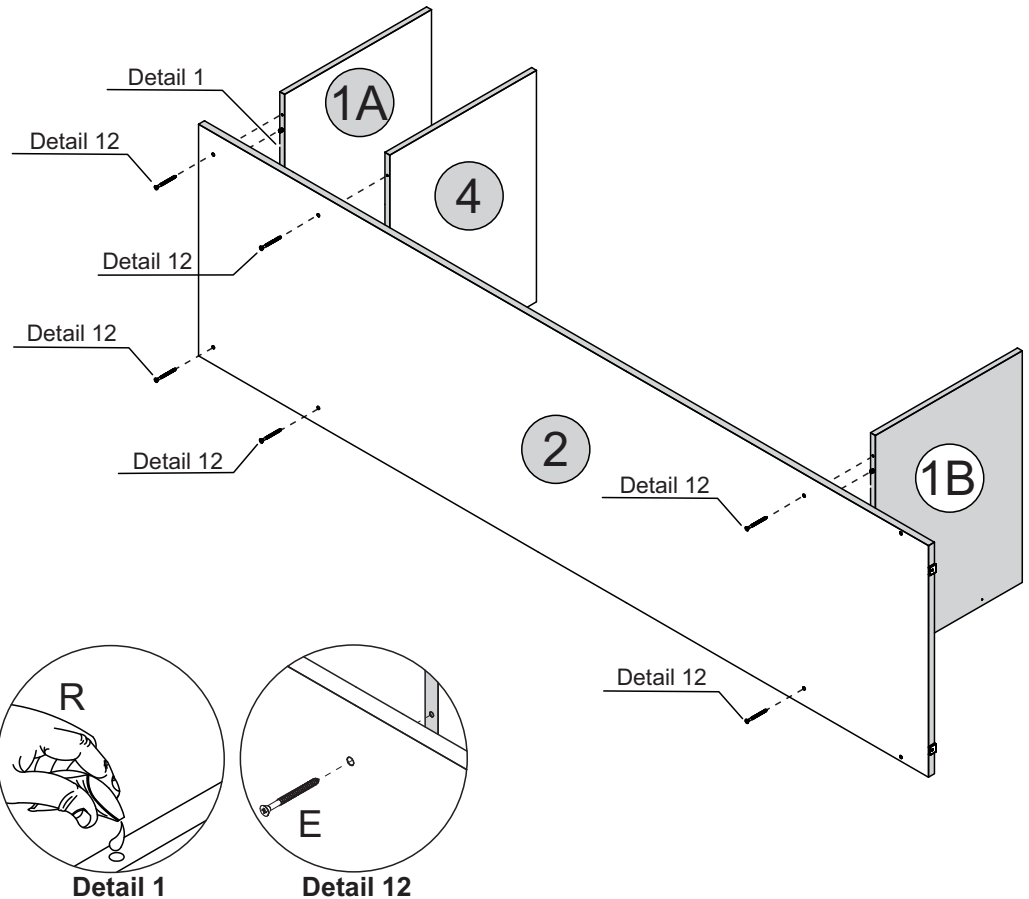
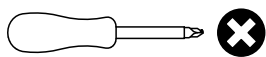



# STEP 8

## PARTS REQUIRED

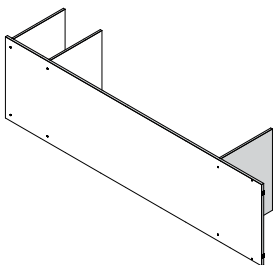
- 6 - FRONT BASEBOARD x1
- 7 - BACK BASEBOARD x1
- 3 - LEFT SIDE PANEL x1

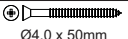

## HARDWARE REQUIRED

- E  10  
Ø4,0 x 50mm
- R  01

## TOOLS REQUIRED

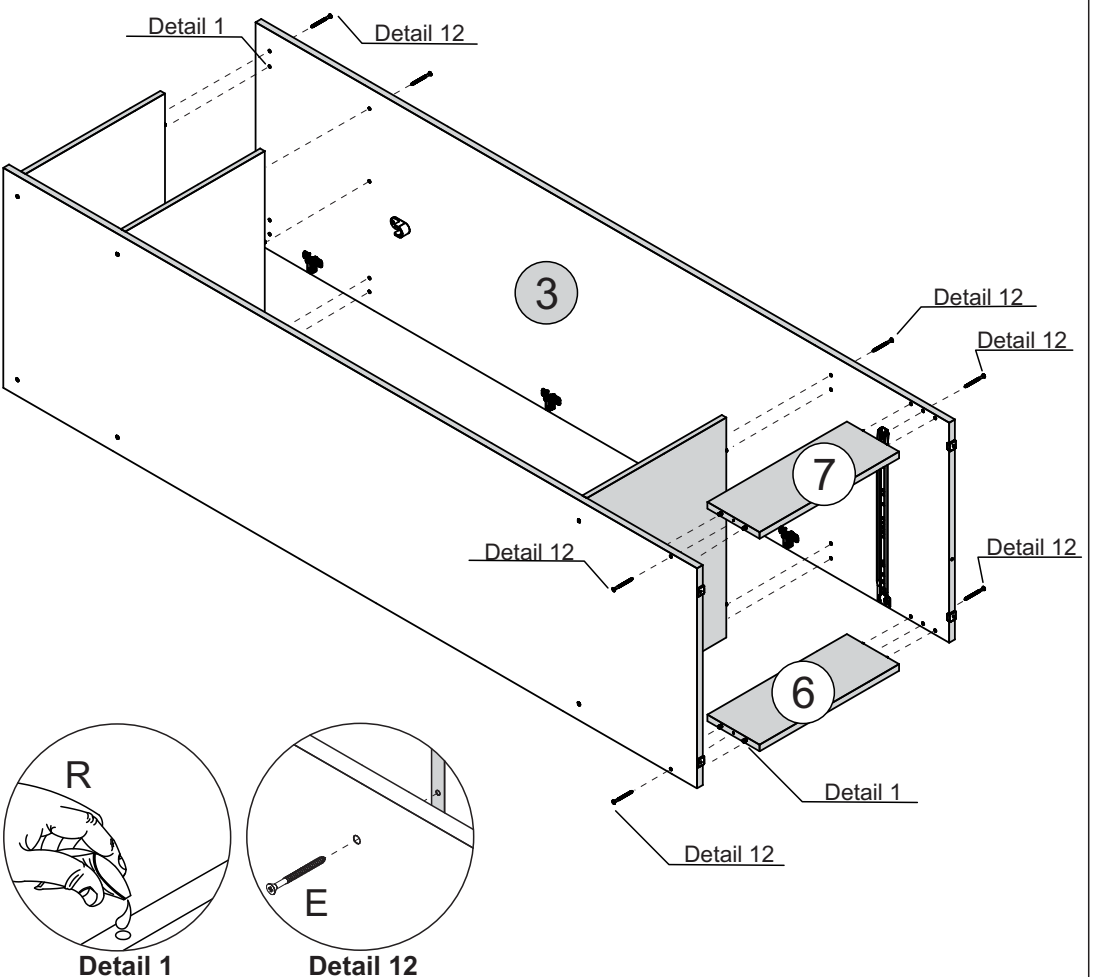
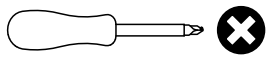

# STEP 9

### PARTS REQUIRED

9 - BACK PANEL x1

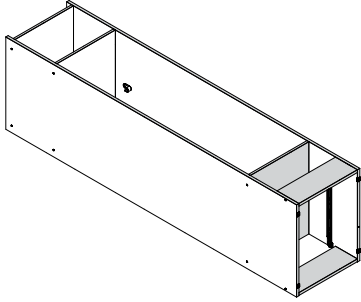

### HARDWARE REQUIRED

G  10 x 10 30

### TOOLS REQUIRED

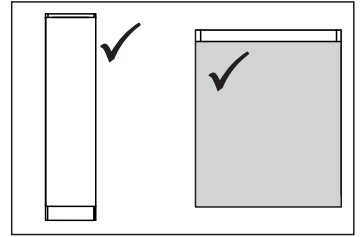
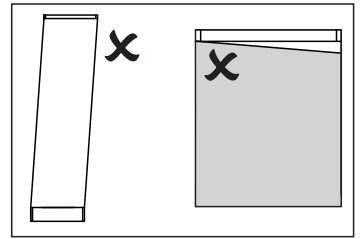
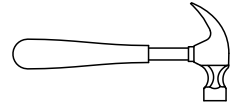

\* For your future reference  
Order Number should be here

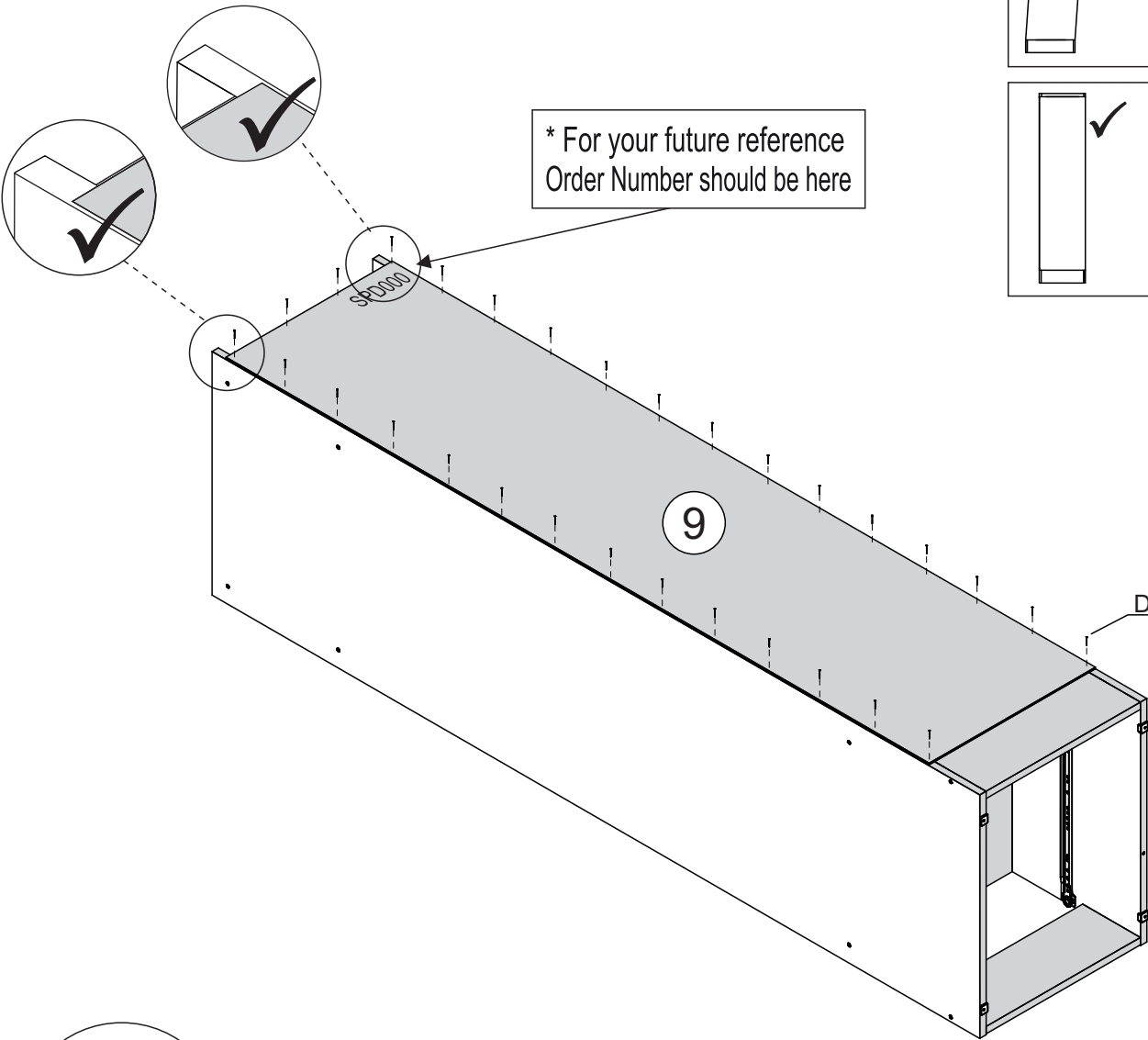

Detail 13

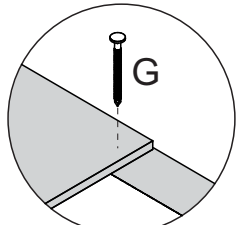

Detail 13



# STEP 10

## PARTS REQUIRED

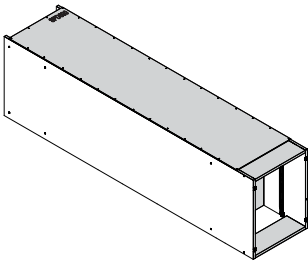

## HARDWARE REQUIRED

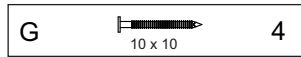

## TOOLS REQUIRED

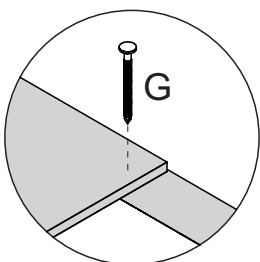
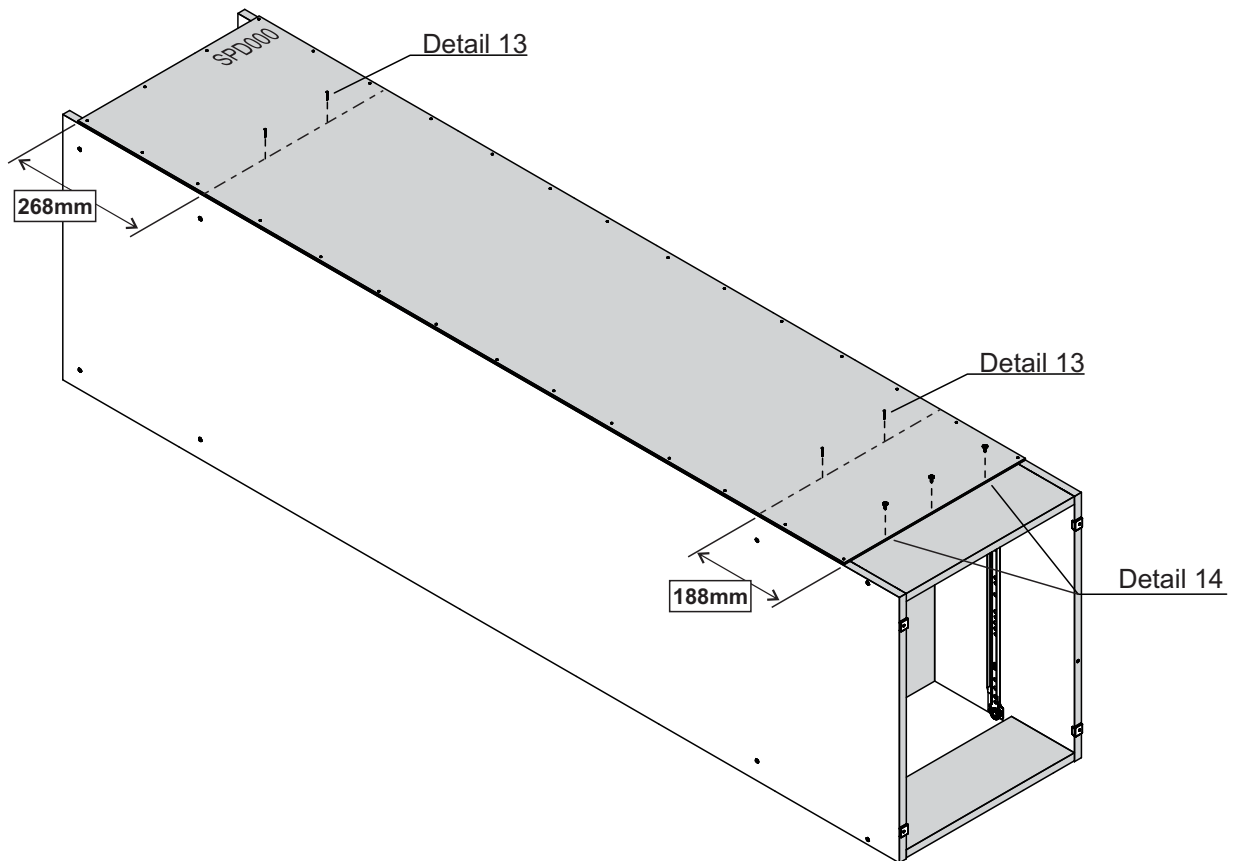
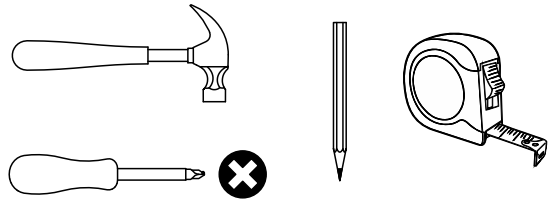

Detail 13

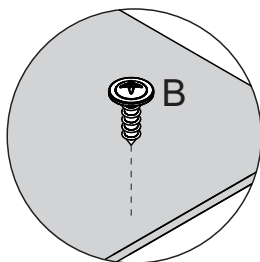

Detail 14

# STEP 11

## PARTS REQUIRED

8 - FRAME x1

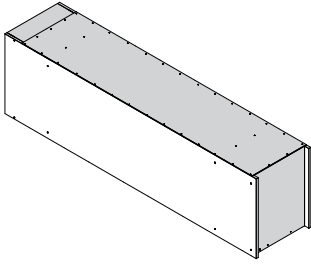

## HARDWARE REQUIRED

I  02

U  06  
Ø4,0 x 12mm

## TOOLS REQUIRED

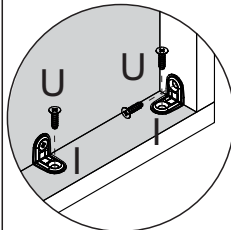
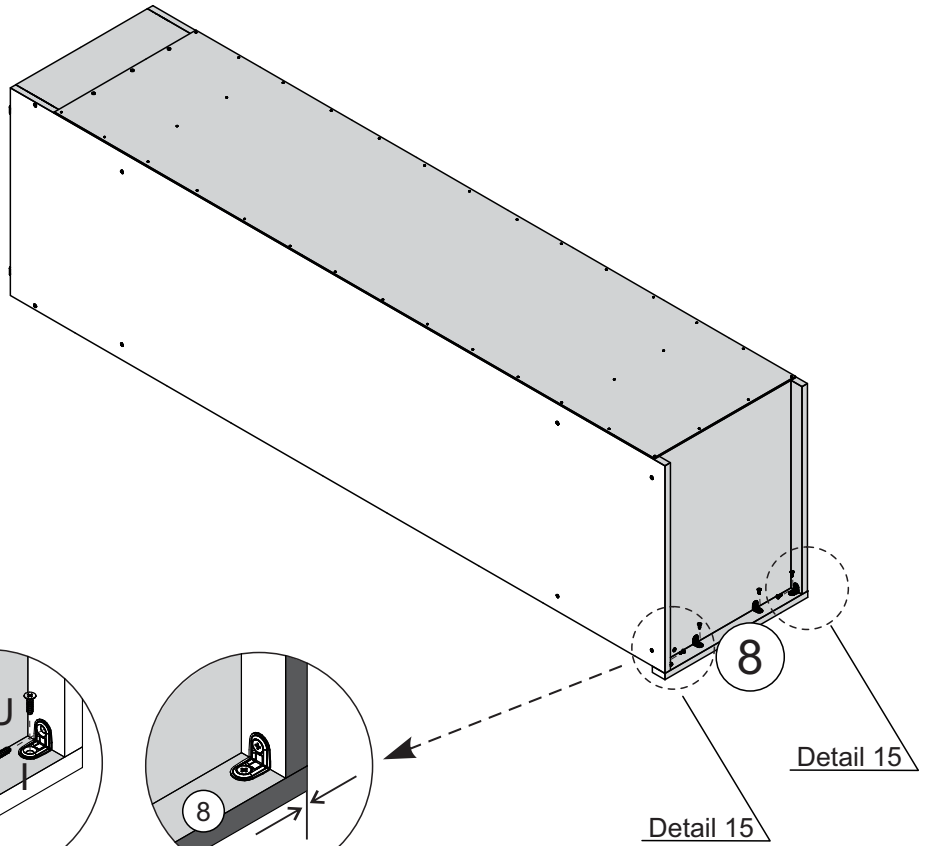
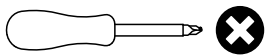

Detail 15

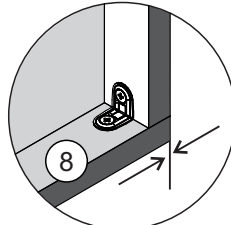

Align corners

# STEP 12

## PARTS REQUIRED

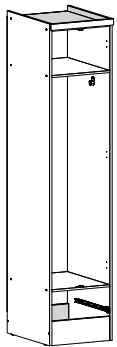

## HARDWARE REQUIRED

X  01

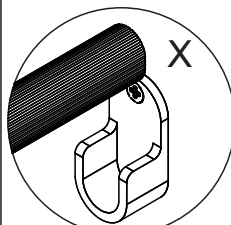
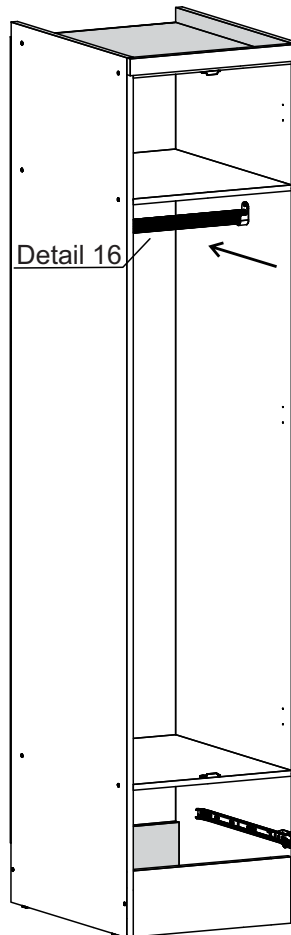

Detail 16

# STEP 13

## PARTS REQUIRED

11 - DRAWER SIDE x2

12 - DRAWER BACK PANEL x1

## HARDWARE REQUIRED

F  08  
Ø6,0 x 30mm

R  01

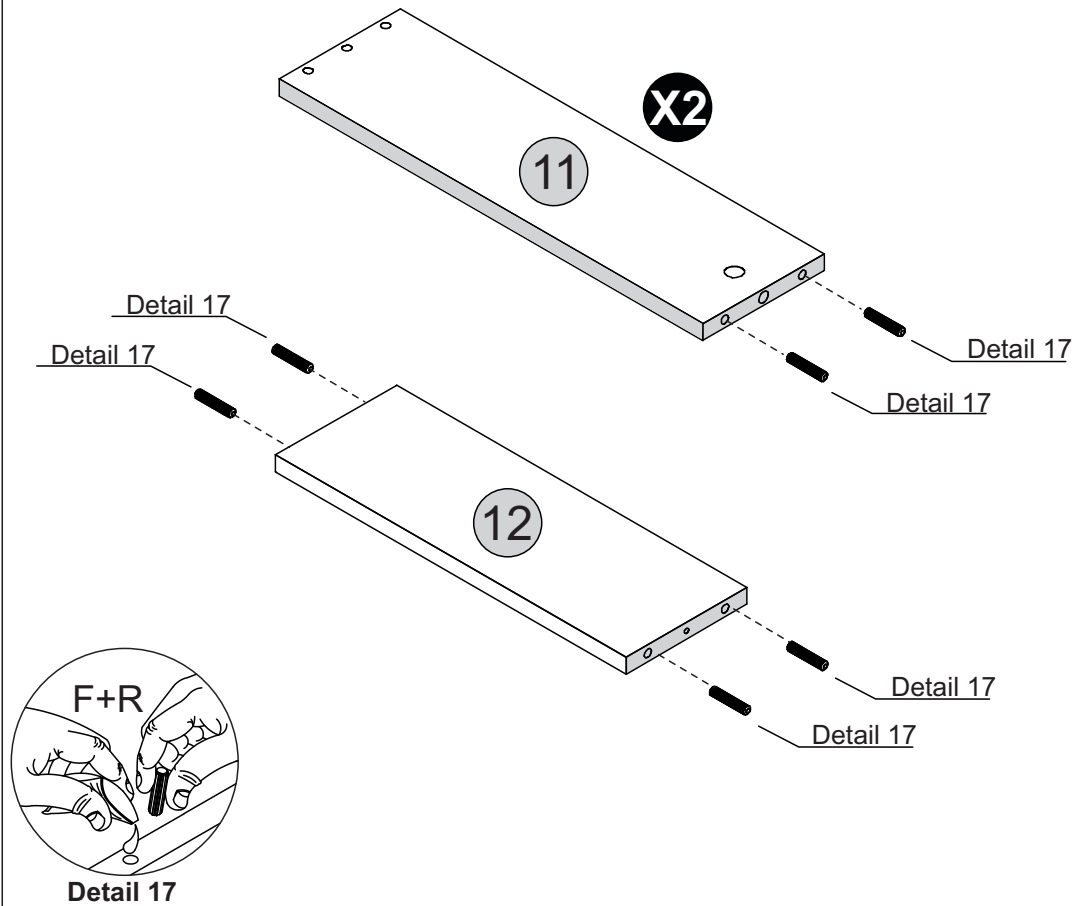

# STEP 14

## PARTS REQUIRED

10 - DRAWER FRONT x1

## HARDWARE REQUIRED

T  02

## TOOLS REQUIRED

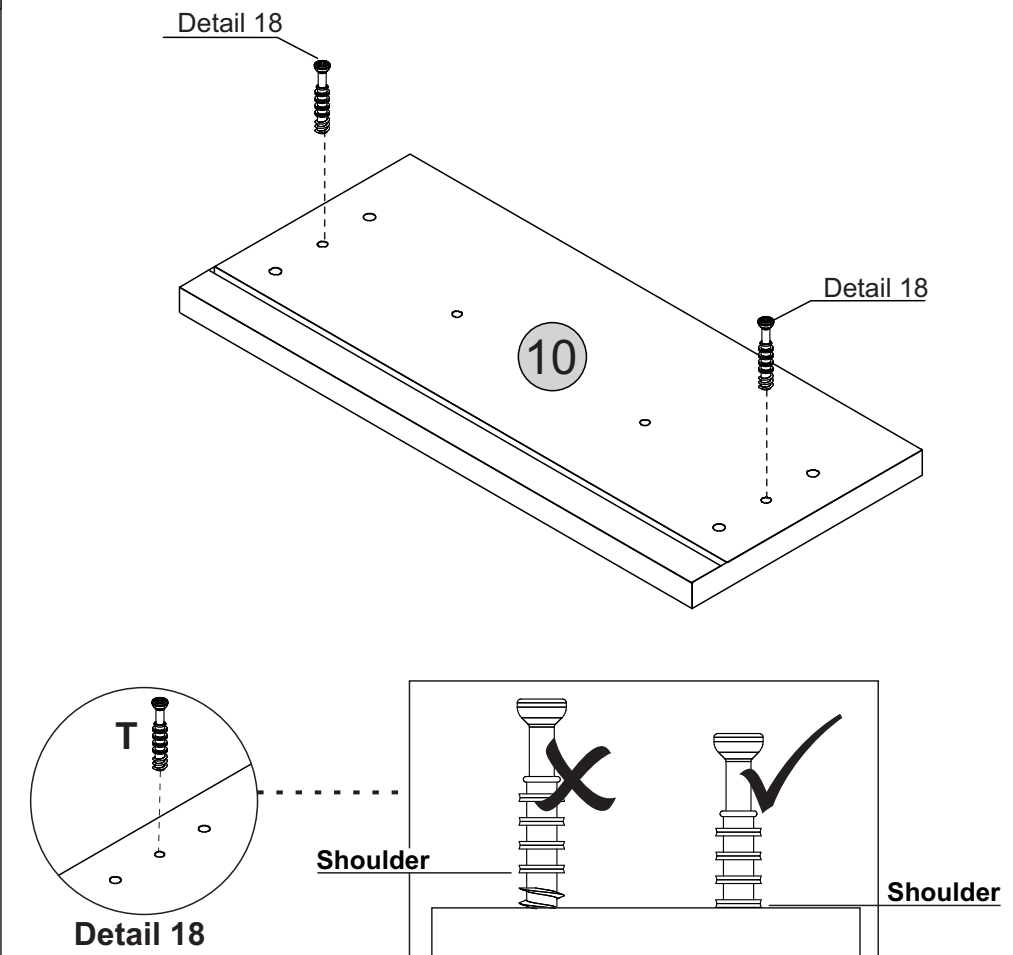
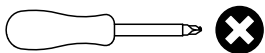

# STEP 15

## PARTS REQUIRED

11 - DRAWER SIDE x2

12 - DRAWER BACK PANEL x1

## HARDWARE REQUIRED

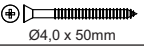
E  02  
Ø4,0 x 50mm

## TOOLS REQUIRED

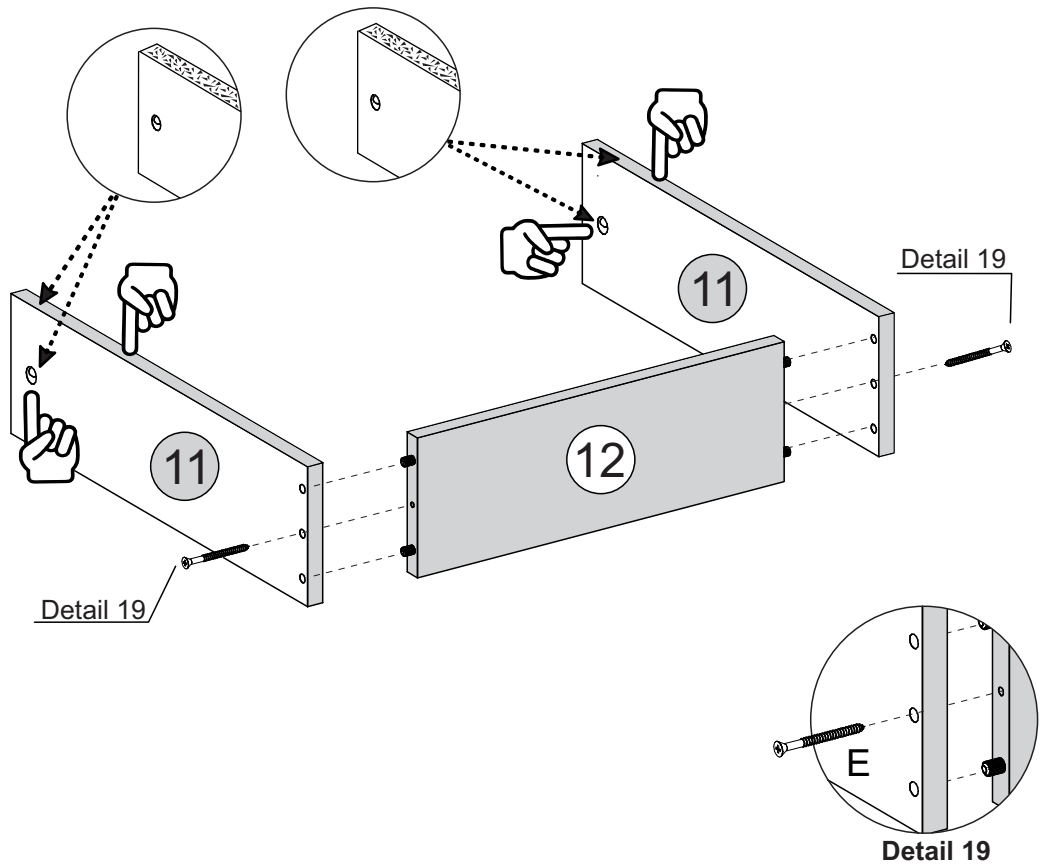
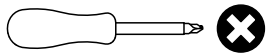

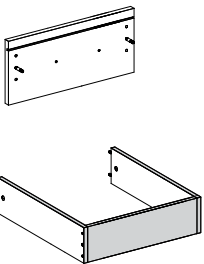

# STEP 16

## PARTS REQUIRED



## HARDWARE REQUIRED

Y  02

R  01

S  02

## TOOLS REQUIRED

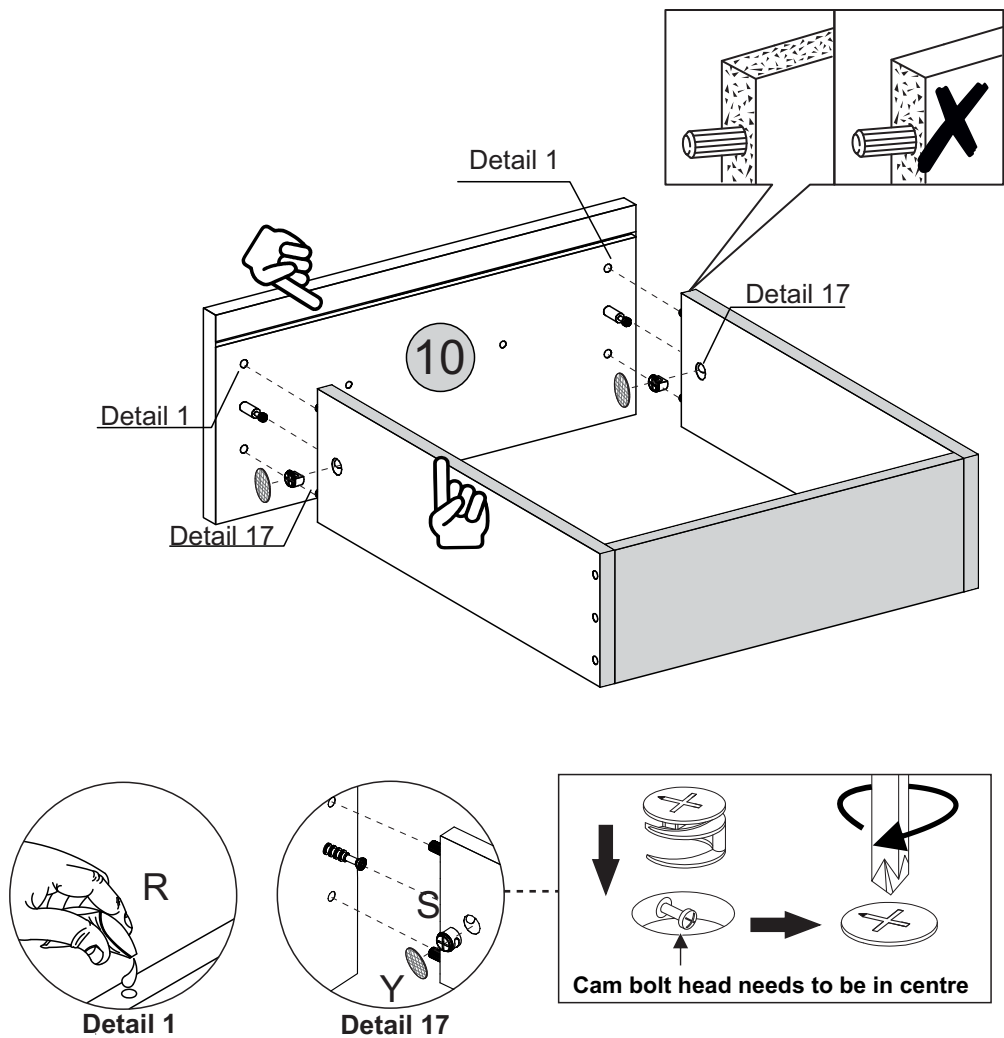
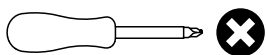

# STEP 17

## PARTS REQUIRED

13 - DRAWER BOTTOM x1

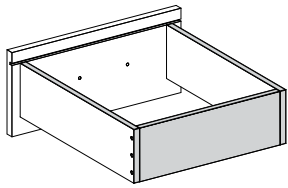

## HARDWARE REQUIRED

G  04  
10 x 10

## TOOLS REQUIRED

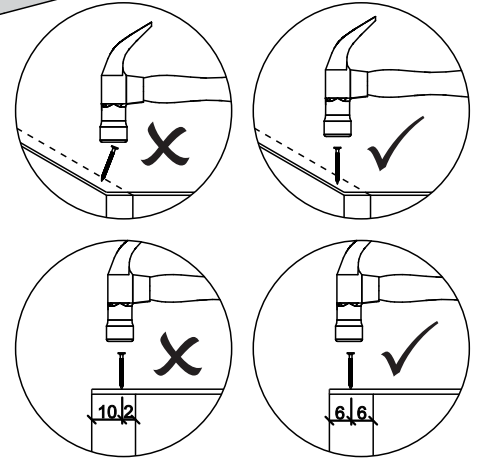
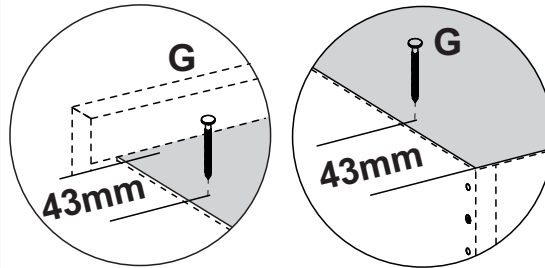
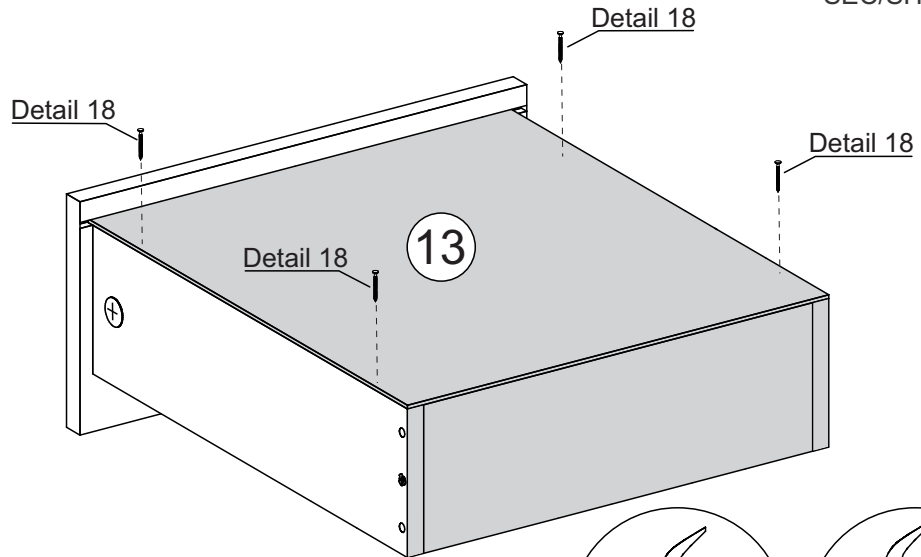
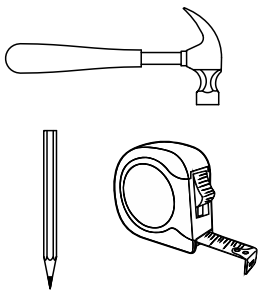

Detail 18

# STEP 18

## PARTS REQUIRED

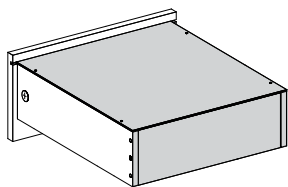

## HARDWARE REQUIRED

G  04  
10 x 10

## TOOLS REQUIRED

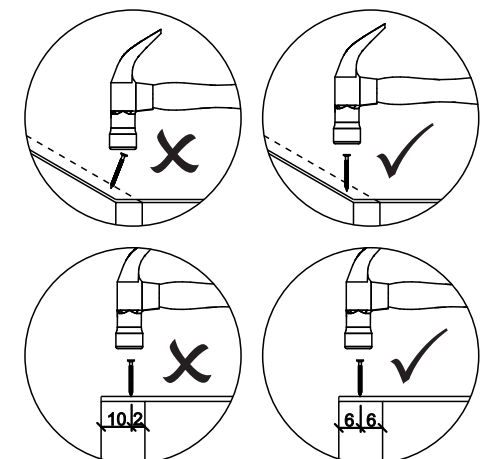
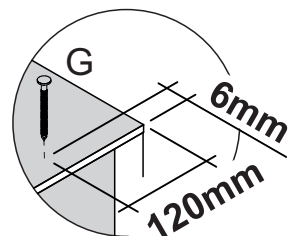
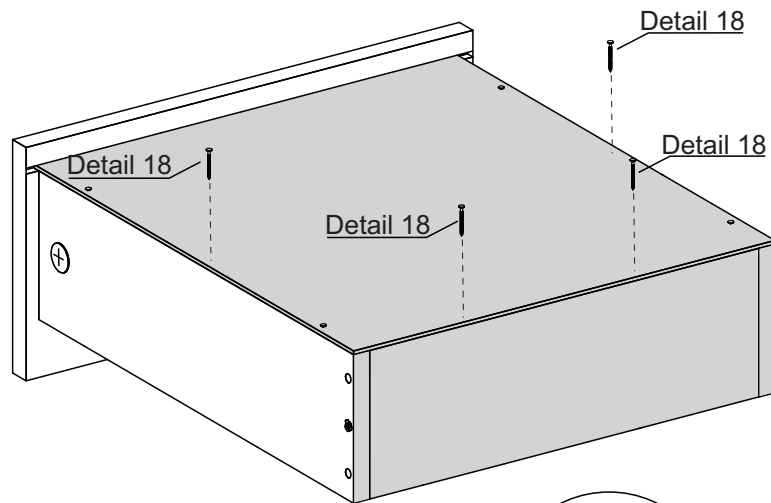
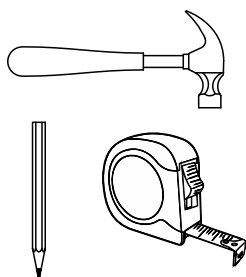

Detail 18

# STEP 19

## PARTS REQUIRED

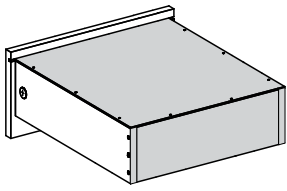

## HARDWARE REQUIRED

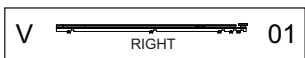
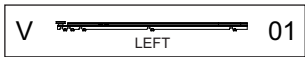
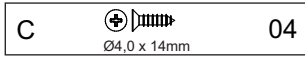

## TOOLS REQUIRED

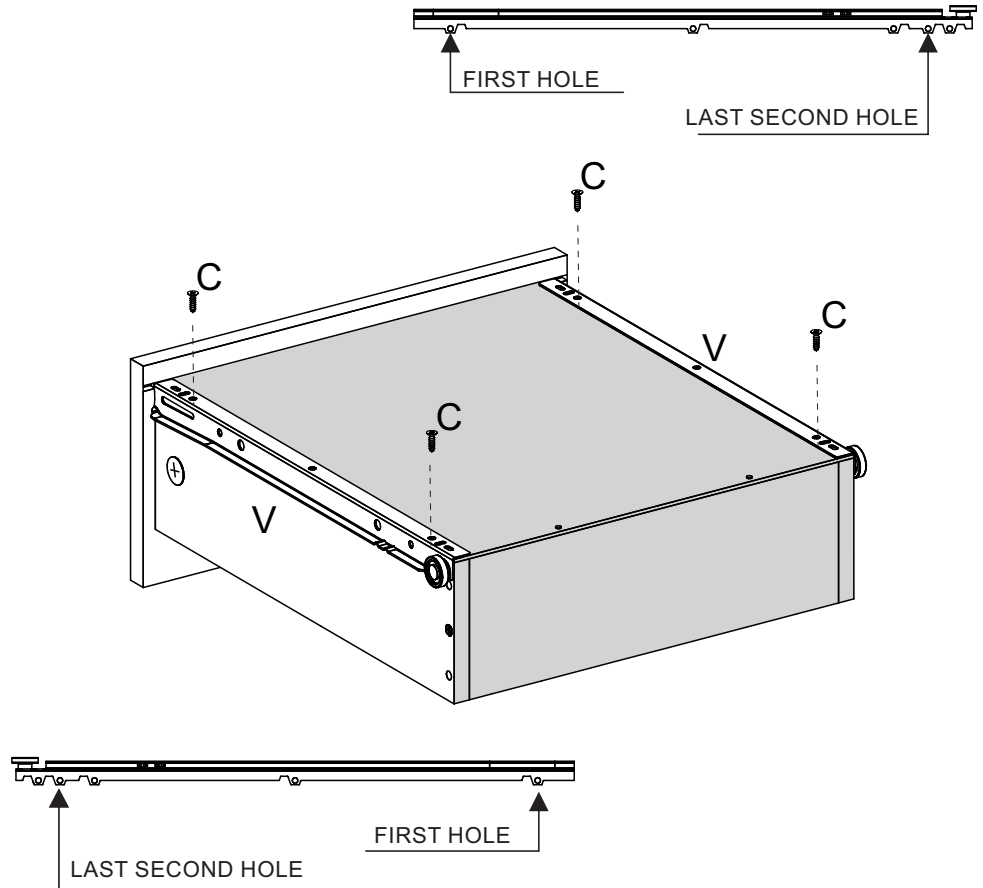
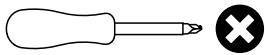

# STEP 20

## PARTS REQUIRED



## HARDWARE REQUIRED

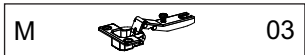
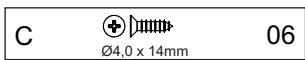

## TOOLS REQUIRED

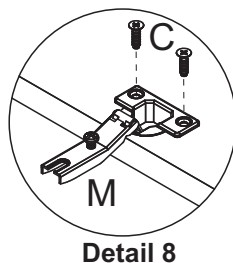
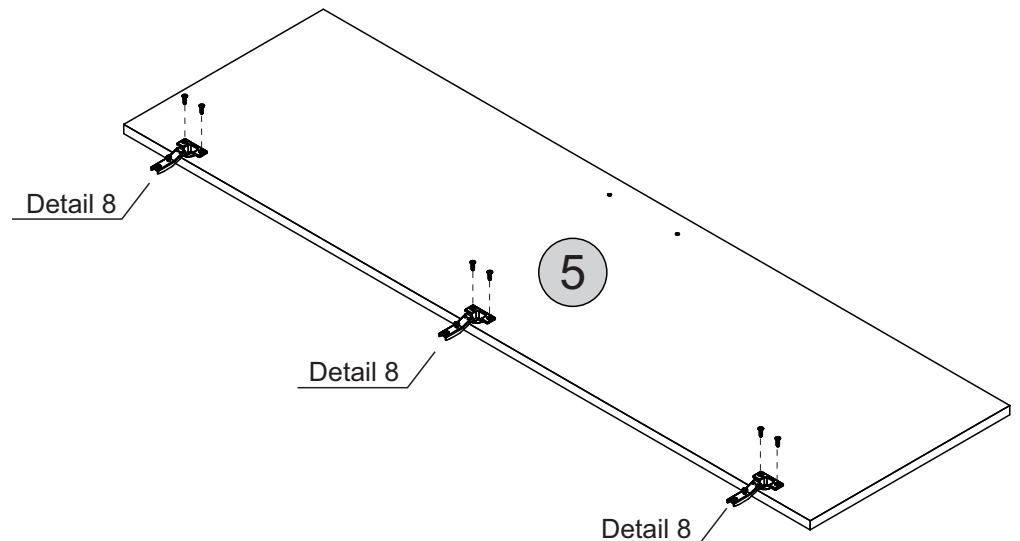
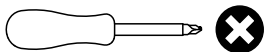

# STEP 21

## PARTS REQUIRED

5 - DOOR x1

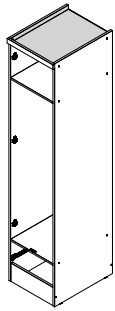

## HARDWARE REQUIRED

Q  16

## TOOLS REQUIRED

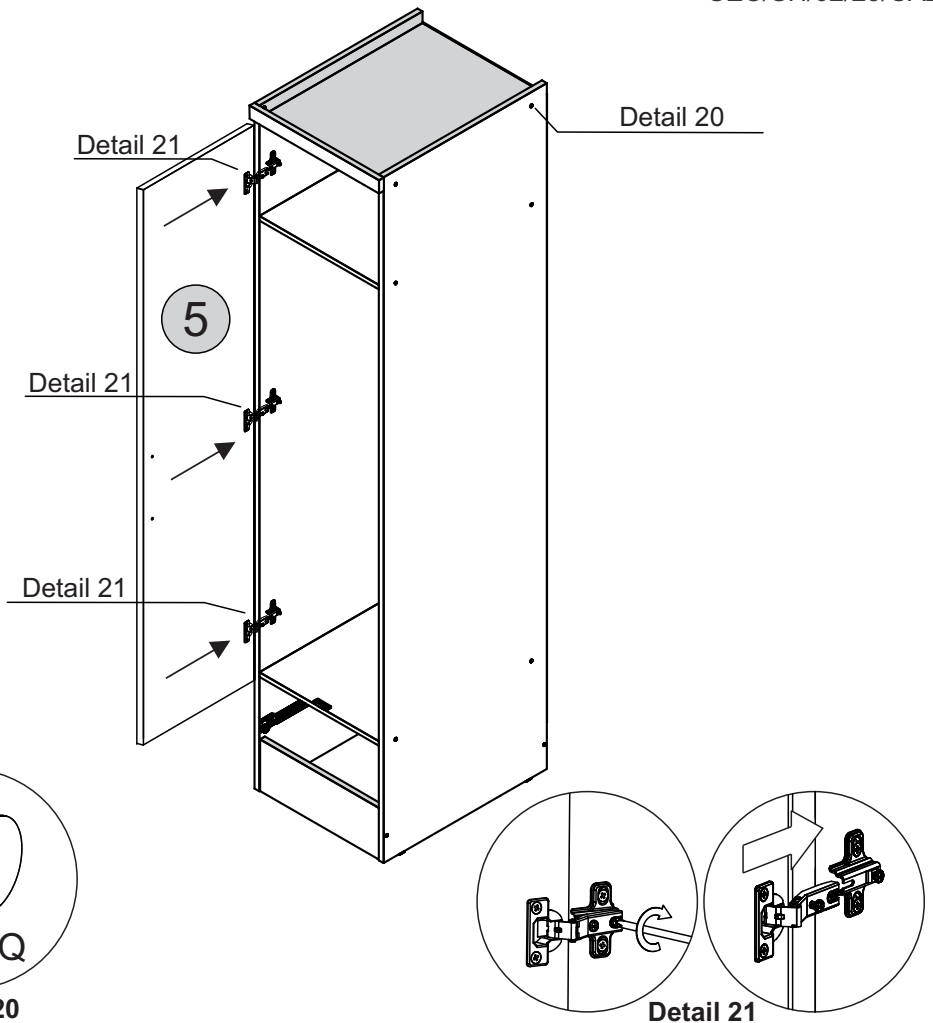
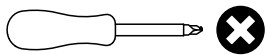

# STEP 22

## PARTS REQUIRED

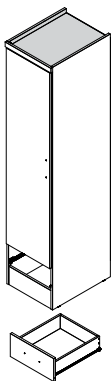

## HARDWARE REQUIRED

D  Ø4,0 x 20mm 04

P  02

## TOOLS REQUIRED

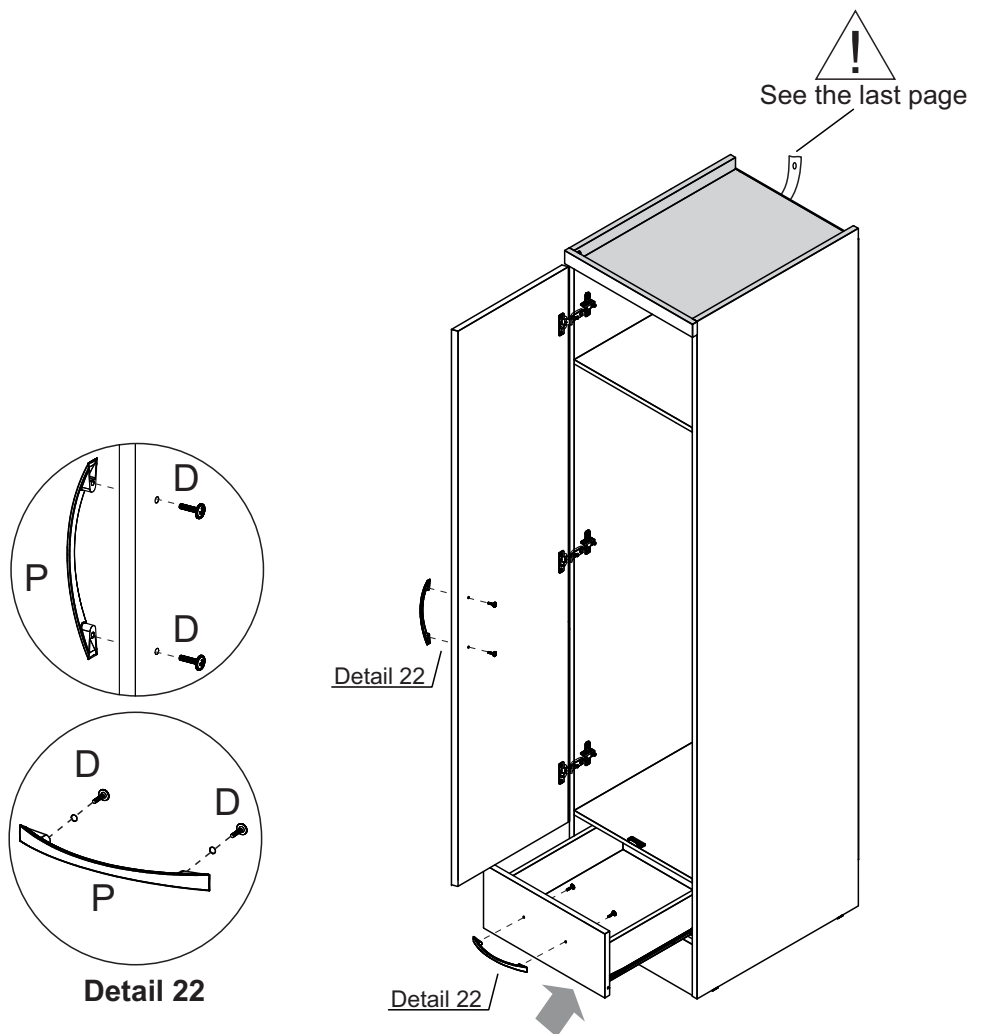
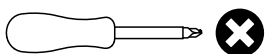

# STEP 23

**TIP**  
If desired, after assembly use an alcohol cleaner to erase the number printed on the parts.

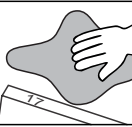

**PARTS REQUIRED**

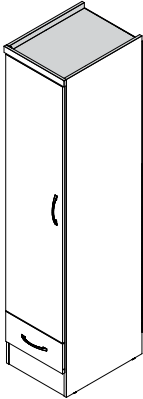

**HARDWARE REQUIRED**

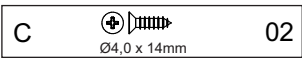

**TOOLS REQUIRED**

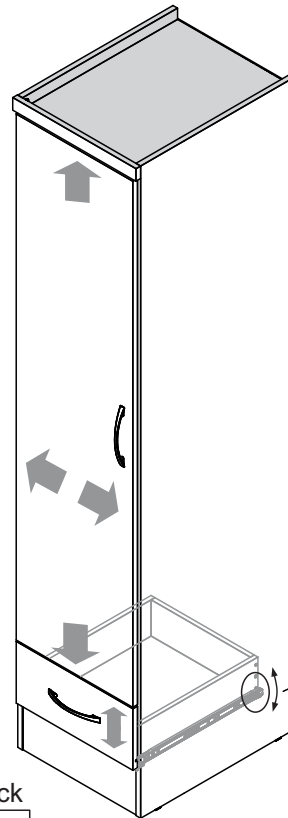
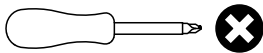

**Height Adjustment**

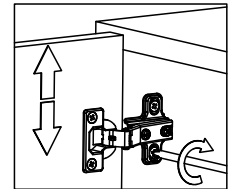

**Internal Adjustment**

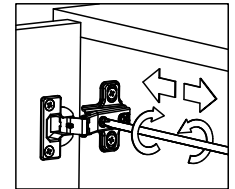

**Depth Adjustment**

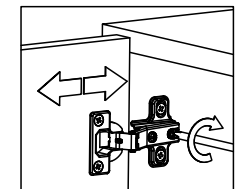
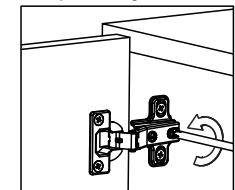

**Drawer Adjustment**   **Drawer Lock**

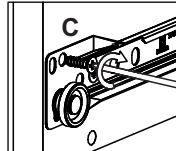
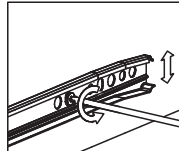

Detail 23

Detail 23

## WARNING

**Serious or fatal injuries can occur from furniture tipping over. To prevent the furniture from tipping over we recommend that it is permanently fixed to the wall.**

Wall fixings are not supplied with this product as different wall materials require different types of fixing devices.

Please make sure you use fixings suitable for the walls in your home.

