

NEVADA 4 DOOR 2 DRAWER WARDROBE ASSEMBLY INSTRUCTIONS

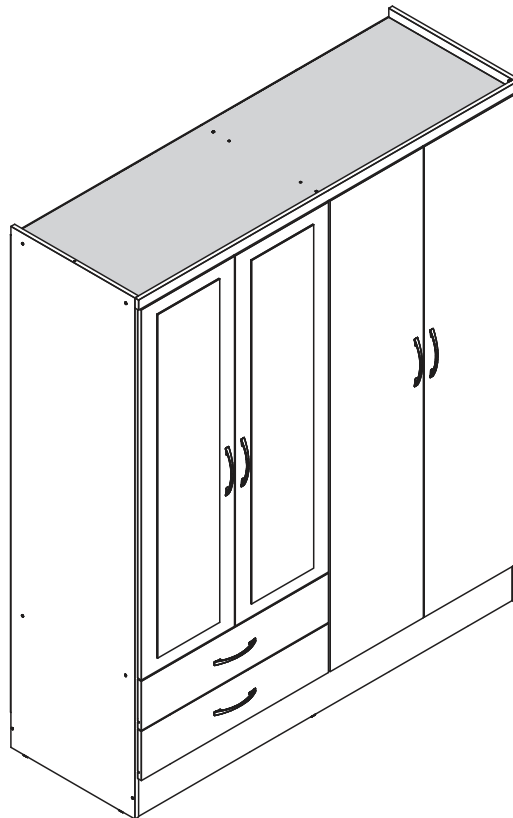

IMPORTANT FOR DOMESTIC USE ONLY

PLEASE READ BEFORE YOU CONTINUE FURTHER

CARE AND MAINTENANCE

After unpacking this product please keep the original packaging in case it needs to be returned for any reason.

- Please ensure all fittings and parts are present before commencing with assembly.
- Never drag or push products as this could cause damage to the joints making it inferior.
- We strongly recommend that you keep children away from your work area.
- We recommend that you lay a blanket or sheet on the floor to avoid damage to both your floor and the product.
- Assemble this product as close to its final position as possible.
- Do not place this product next to a radiator or in direct sunlight.
- Do not drag or push items across your high gloss furniture as this may cause the surface to scratch
- Wood is a natural product and may expand if subjected to damp and may shrink or crack if subjected to heat. Therefore it is recommended that room temperature is maintained, with no sudden temperature fluctuations.
- Make sure any spillage is wiped off immediately.
- Do not place hot or chilled items directly on to the surface, use a place mat or marking will occur.
- For general cleaning use a soft cotton or micro fibre cloth, and do not use detergents of any kind.
- From time to time it may be necessary to tighten fittings, regular inspections should be carried out.
- Do not place on a wet or damp floor as staining may occur to your floor.



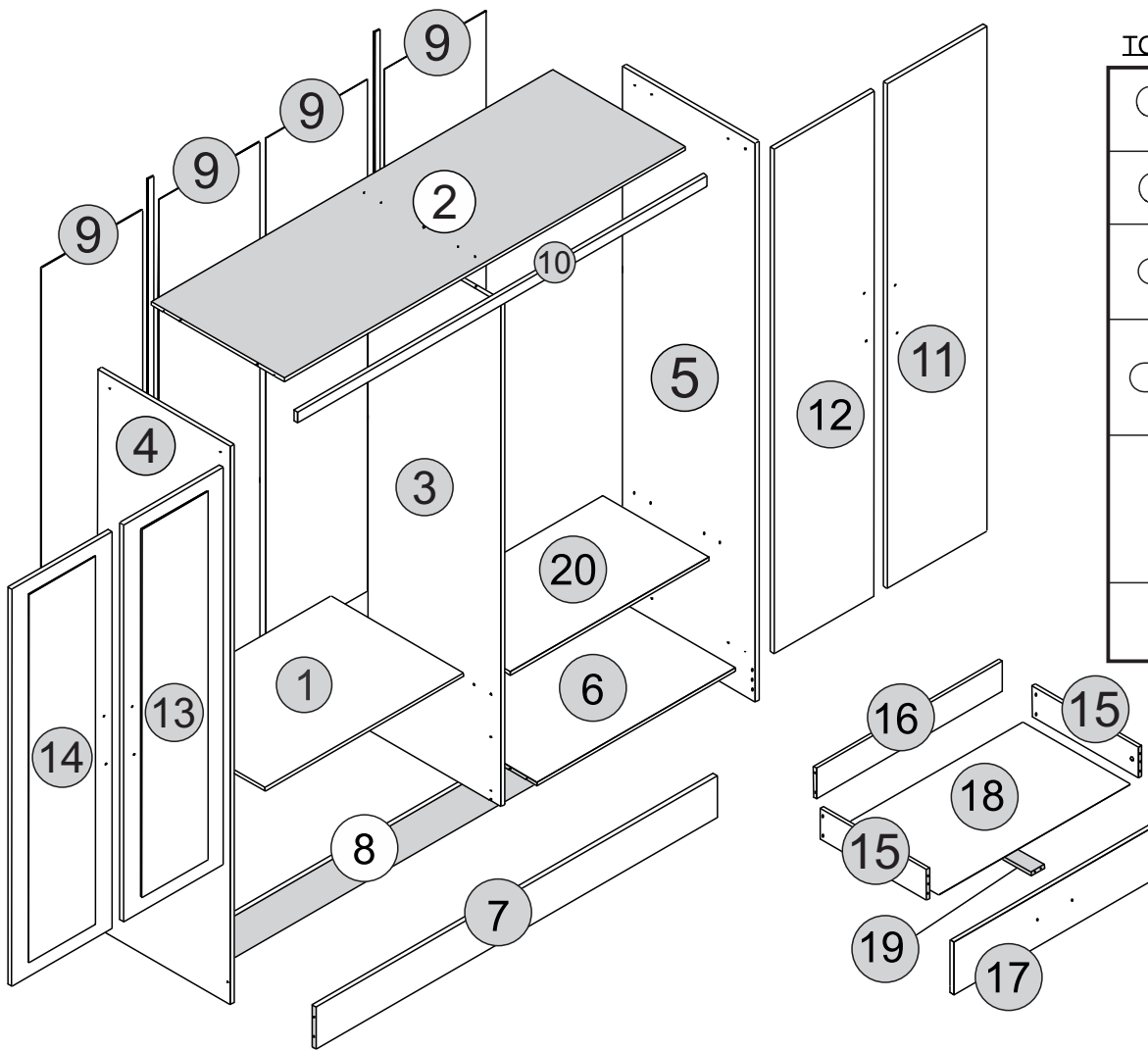
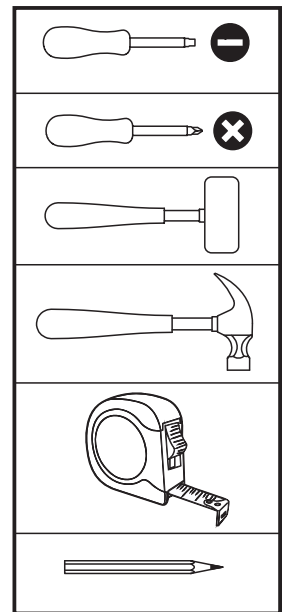







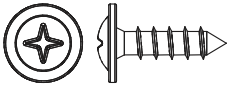
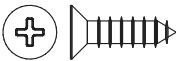
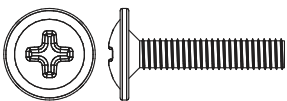

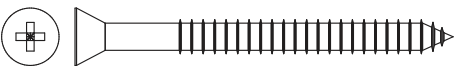
TOOLS REQUIRED

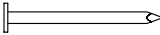
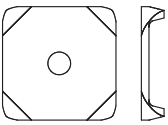
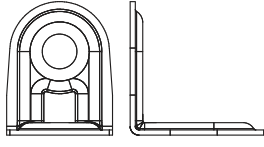

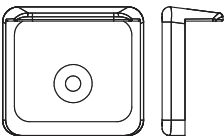
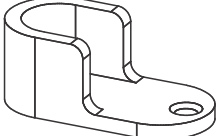
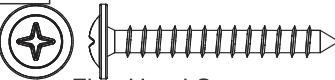
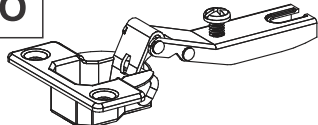
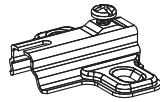
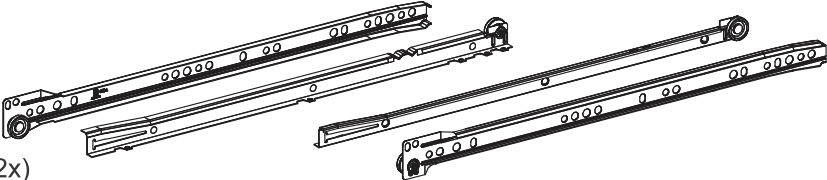
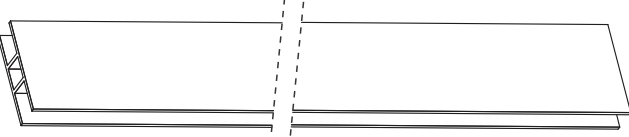
Please Note:
The below parts have all been stamped with the part number to help identify them during assembly.

Part Number	Part Description	Quantity	Carton
1	Drawer Top	1	1/3
2	Top Panel	1	2/3
3	Division Panel	1	2/3
4	Left Side Panel	1	1/3
5	Right Side Panel	1	1/3
6	Base Panel	1	1/3
7	Front Baseboard	1	2/3
8	Back Baseboard	1	2/3
9	Back Panel	4	2/3
10	Frame	1	2/3
11	Right Large Door	1	3/3
12	Left Large Door	1	3/3
13	Right Small Door	1	3/3
14	Left Small Door	1	3/3
15	Drawer Side	4	1/3
16	Drawer Back Panel	2	2/3
17	Drawer Front	2	1/3
18	Drawer Bottom	2	2/3
19	Drawer Bottom Support Bar	2	2/3
20	Shelf	1	1/3

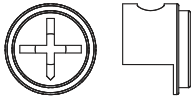
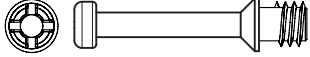
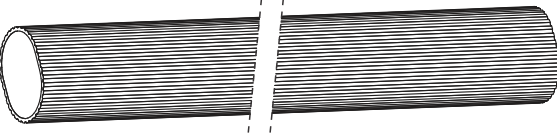
FITTINGS LIST

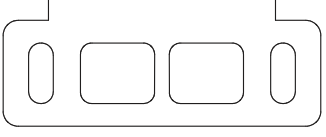
<p>A</p>  <p>Flat Head Screw Ø6,0 x 8mm (8x)</p> <p>+1+</p>	<p>B</p>  <p>Flan Head Screw Ø3,5 x 12mm (20x)</p> <p>+1/2</p>	<p>C</p>  <p>Flat Head Screw Ø4,0 x 14mm (68x)</p> <p>+1/2</p>	<p>D</p>  <p>Flan Head Screw Ø4,0 x 20mm (12x)</p> <p>+1/2</p>	
<p>E</p>  <p>Flat Head Screw Ø3,5 x 25mm (2x)</p> <p>+1/1</p>		<p>F</p>  <p>Flat Head Screw Ø4,0 x 45mm (28x)</p> <p>+1/2</p>		<p>G</p>  <p>+1/2 Dowel Ø6,0 x 30mm (46x)</p>
<p>H</p>  <p>Nail 10 x 10 (100X)</p> <p>+1/5</p>	<p>I</p>  <p>Back Panel Bracket (14x)</p> <p>+1/2</p>	<p>J</p>  <p>+1 'L' Metallic Support (6x)</p>	<p>K</p>  <p>+1/1 Washer (4x)</p>	
<p>L</p>  <p>Plastic Foot (6x)</p> <p>+1/1</p>	<p>M</p>  <p>Hanging Rail Support (4x)</p>	<p>N</p>  <p>Flan Head Screw Ø3,5 x 30mm (2x)</p> <p>+1/1</p>	<p>O</p>  <p>Hinge (12x)</p>	
<p>P</p>  <p>Hinge Plate (12x)</p>	<p>Q</p>  <p>Drawer Runners (2x)</p>			
<p>R</p>  <p>Back Panel Strip (2x)</p>	<p>S</p>  <p>Strap (2x)</p>	<p>T</p>  <p>Handle (6x)</p>		
<p>U</p>  <p>Hole Plugs (28x)</p> <p>+1/2</p>	<p>V</p>  <p>Glue (2x)</p>	<p>W</p>  <p>Cam Nut (4x)</p> <p>+1/1</p>	<p>X</p>  <p>Cam Bolt (4x)</p> <p>+1/1</p>	
<p>Y</p>  <p>Hanging Rail (2x)</p>	<p>Z</p>  <p>Flat Head Screw Ø4,0 x 12mm (12x)</p> <p>+1/2</p>	<p>A1</p>  <p>Door Support (4x)</p>		

TIPS FOR FITTINGS CAM-LOCKS

WHEN FITTING CAM NUT, ENSURE STARTING POSITION IS CORRECT BEFORE YOU INSERT CONNECTING CAM BOLT TURN CLOCKWISE UNTIL SECURE

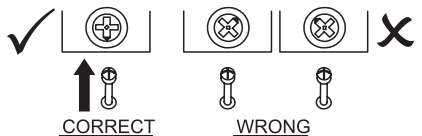

CORRECT WRONG WRONG

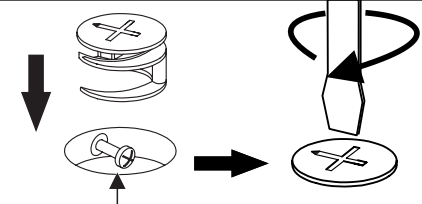

Cam bolt head needs to be in centre

CAMBOLT

Tighten until shoulder in flush with panel. Do not overtighten or undertighten (see example beside)

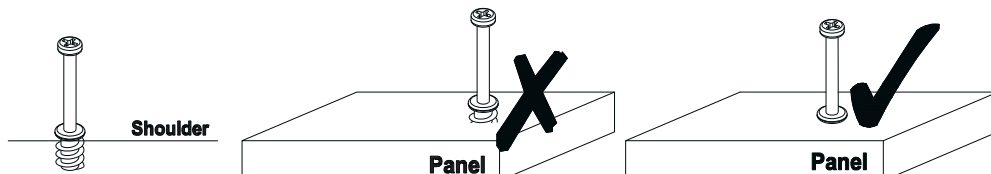



STEP 1

PARTS REQUIRED

4 - LEFT SIDE PANEL x1

HARDWARE REQUIRED

C  08
Ø4,0 x 14mm

H  02

L  02

M  01

P  03

TOOLS REQUIRED

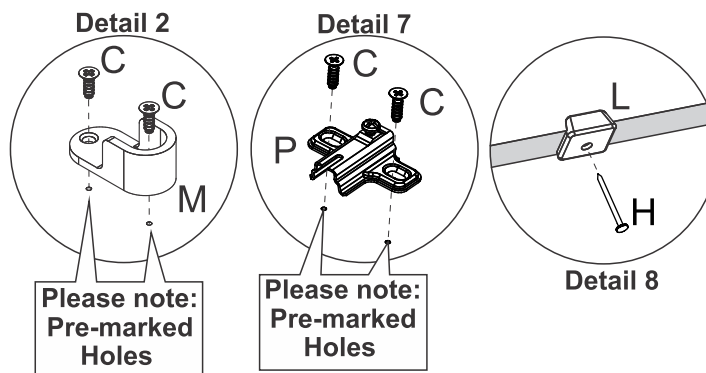
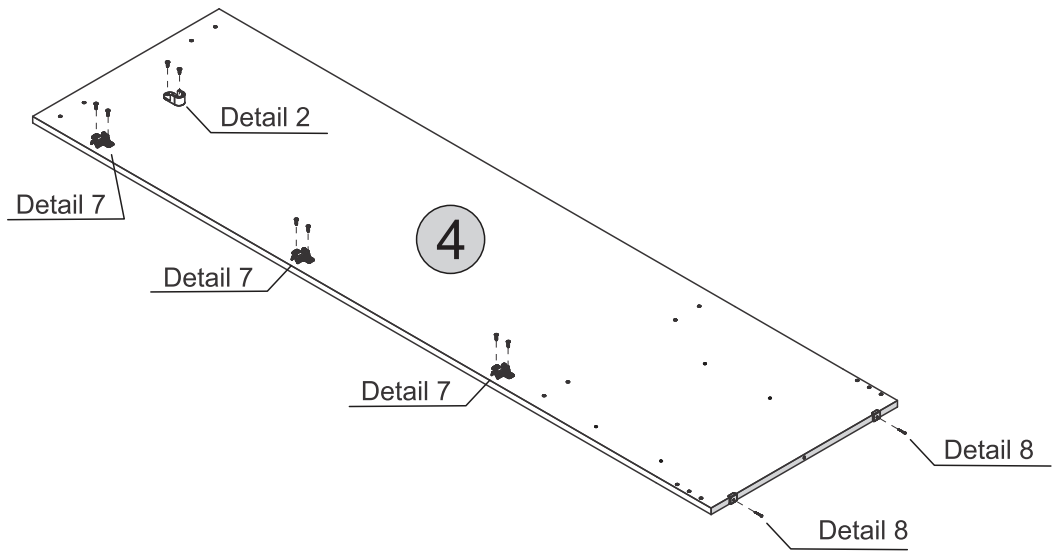
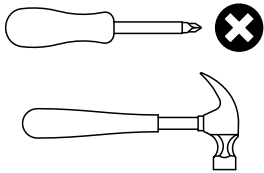

Please note:
Pre-marked
Holes

Please note:
Pre-marked
Holes

Detail 8

STEP 2

PARTS REQUIRED

4 - LEFT SIDE PANEL x1

HARDWARE REQUIRED

A  04
Ø6,0 x 8mm

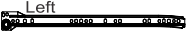
Q  02

TOOLS REQUIRED

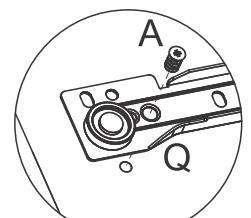
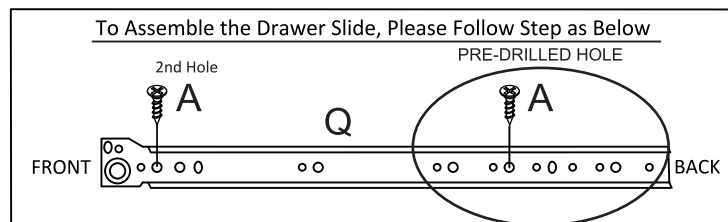
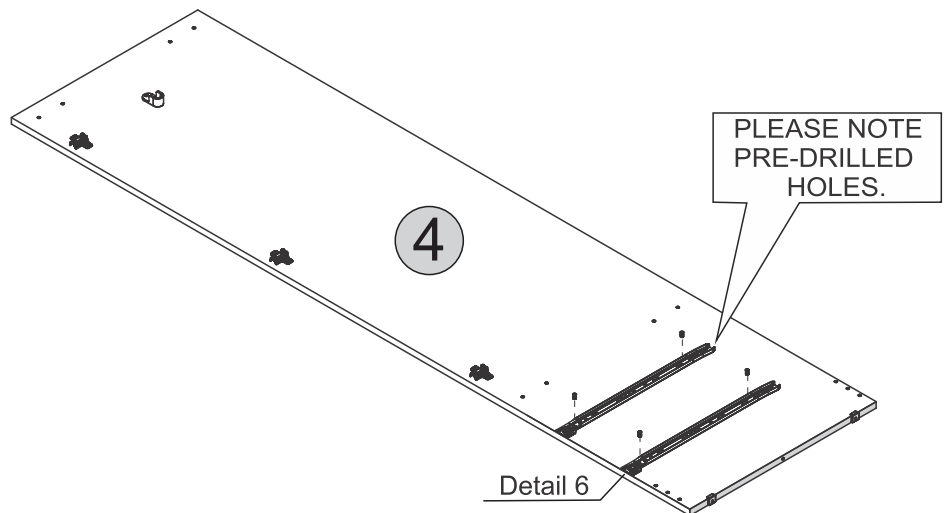
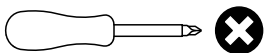

Detail 6

STEP 3

PARTS REQUIRED

3 - DIVISION PANEL x1

HARDWARE REQUIRED

C  08
Ø4,0 x 14mm

G  04
Ø6,0 x 30mm

M  01

P  03

V  01
Glue

TOOLS REQUIRED

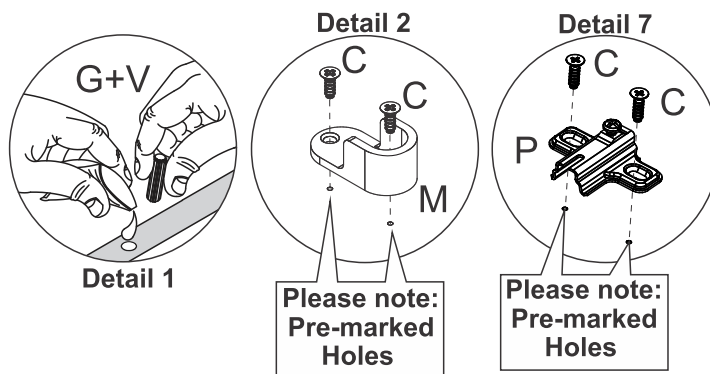
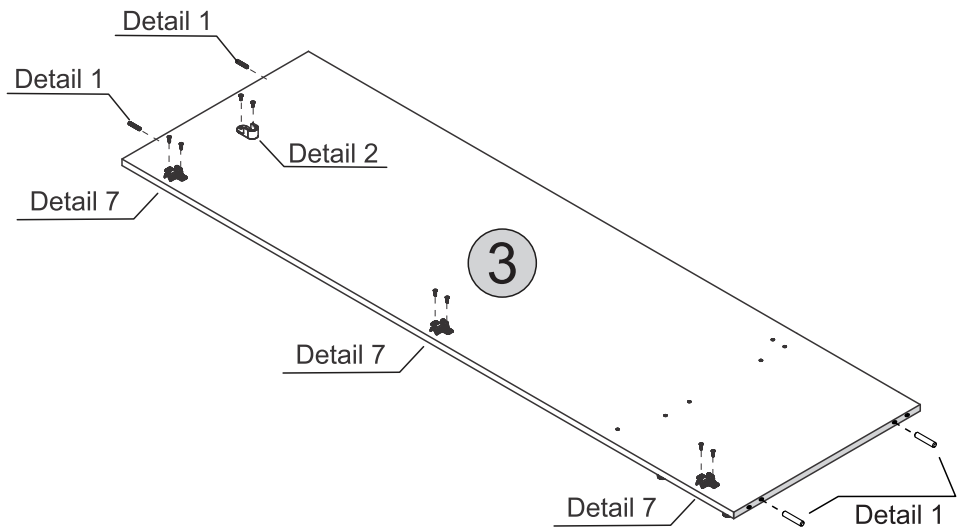
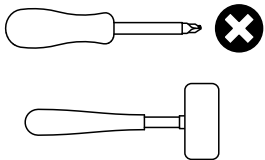

STEP 4

PARTS REQUIRED

3 - DIVISION PANEL x1

HARDWARE REQUIRED

C  08
Ø4,0 x 14mm

M  01

P  03

TOOLS REQUIRED

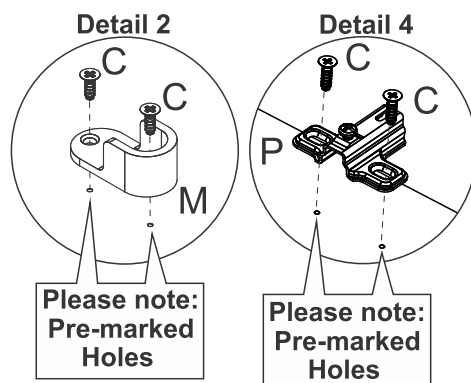
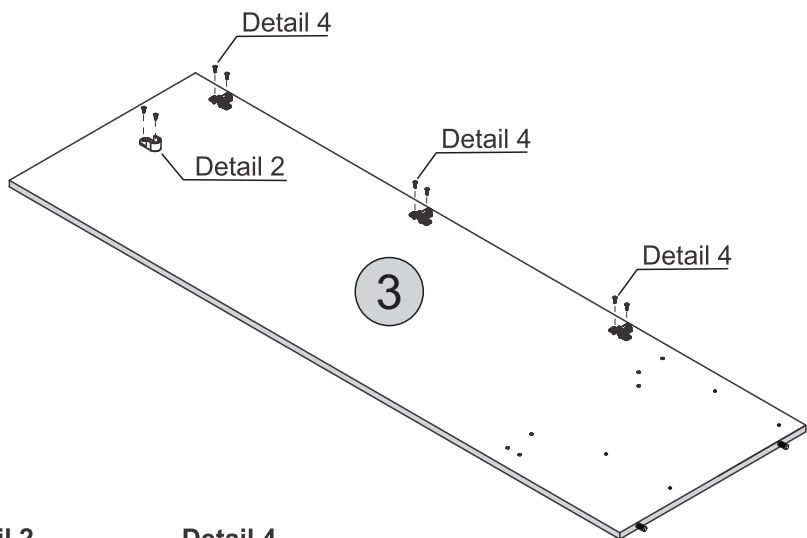
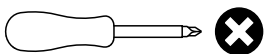

STEP 5

PARTS REQUIRED

3 - DIVISION PANEL x1

HARDWARE REQUIRED

A  04
Ø6,0 x 8mm

Q  02
Right

TOOLS REQUIRED

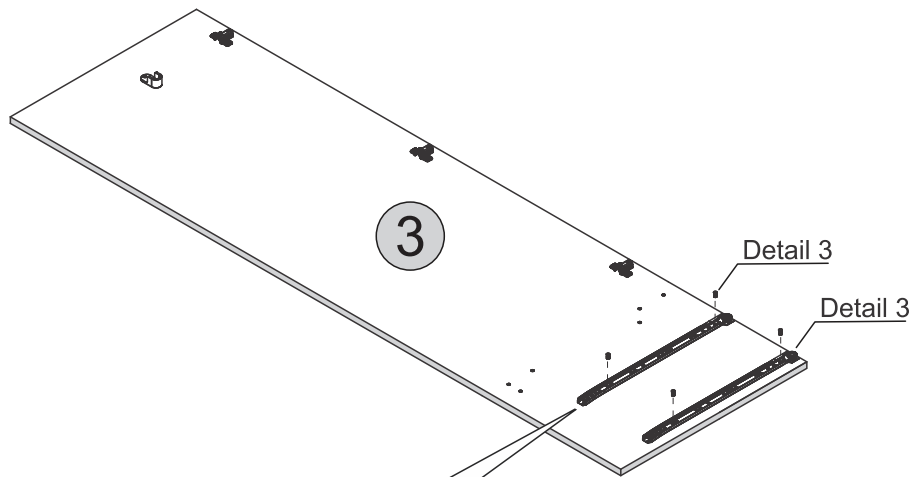
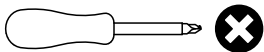

PLEASE NOTE
PRE-DRILLED
HOLES.

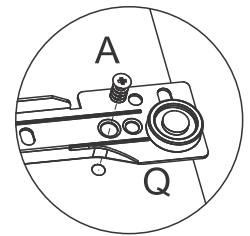
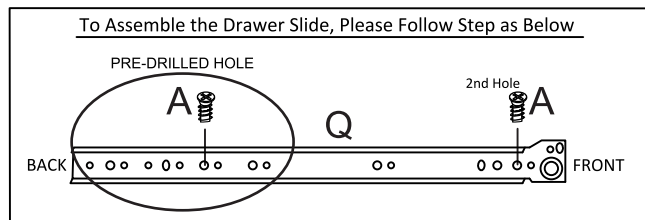

Detail 3

STEP 6

PARTS REQUIRED

5 - RIGHT SIDE PANEL x1

HARDWARE REQUIRED

C  08
Ø4,0 x 14mm

H  02

L  02

M  01

P  03

TOOLS REQUIRED

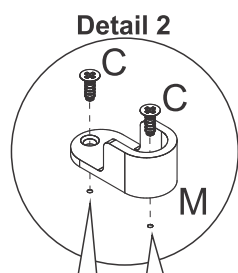
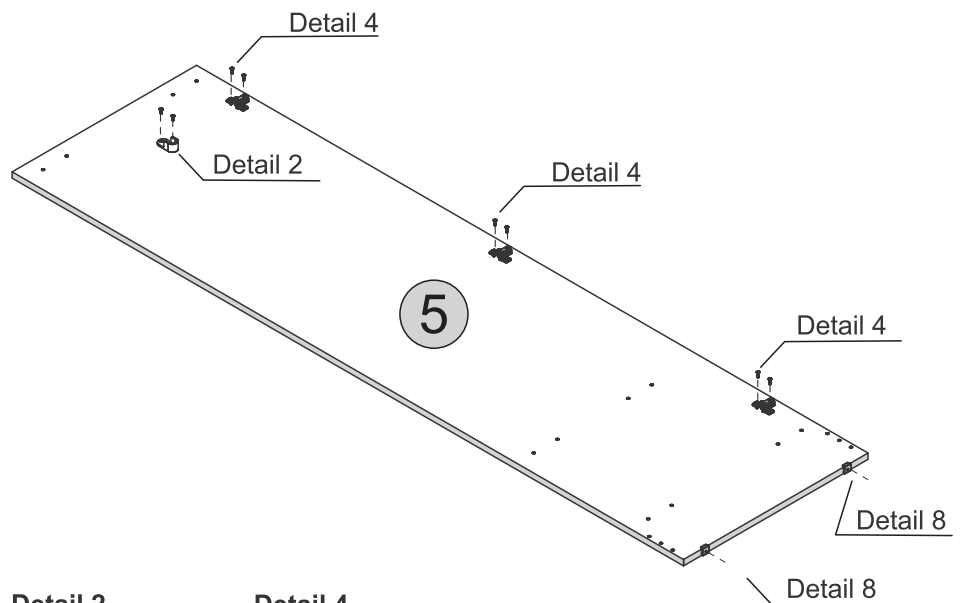
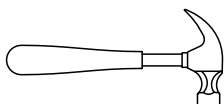
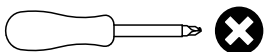

Please note:
Pre-marked
Holes

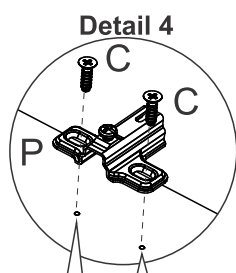

Please note:
Pre-marked
Holes

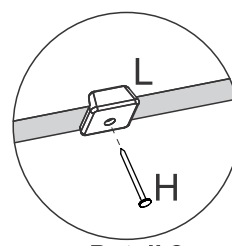

Detail 8

STEP 7

PARTS REQUIRED

7 - FRONT BASEBOARD x1

8 - BACK BASEBOARD x1

HARDWARE REQUIRED

H  02

L  02

G  Ø6,0 x 30mm 08

V  01

TOOLS REQUIRED

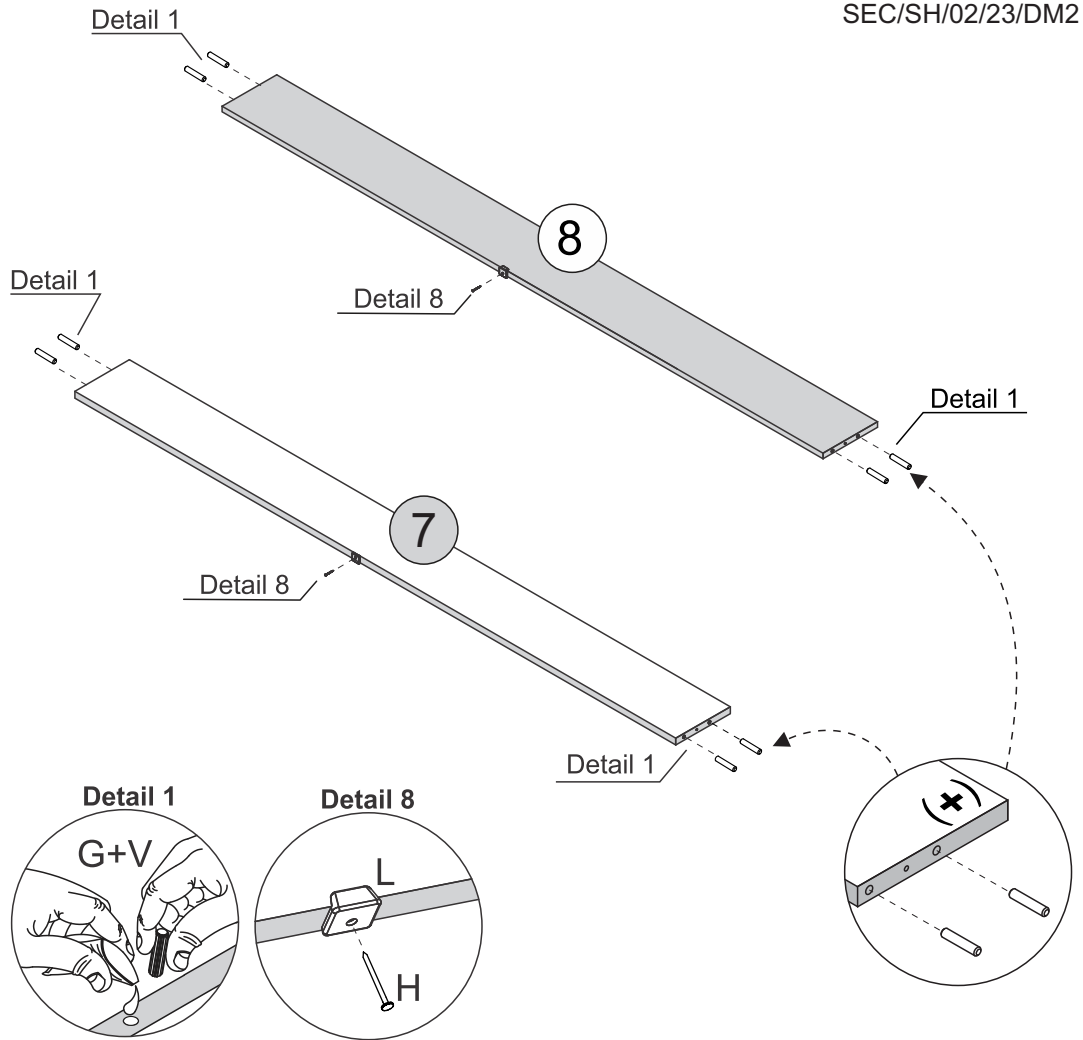
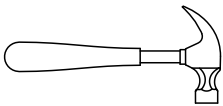
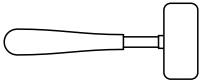

STEP 8

PARTS REQUIRED

1 - DRAWER TOP x1

6 - BASE PANEL x1

20 - SHELF x1

HARDWARE REQUIRED

B  Ø3,5 x 12mm 04

G  Ø6,0 x 30mm 10

V  01

A1  02

TOOLS REQUIRED

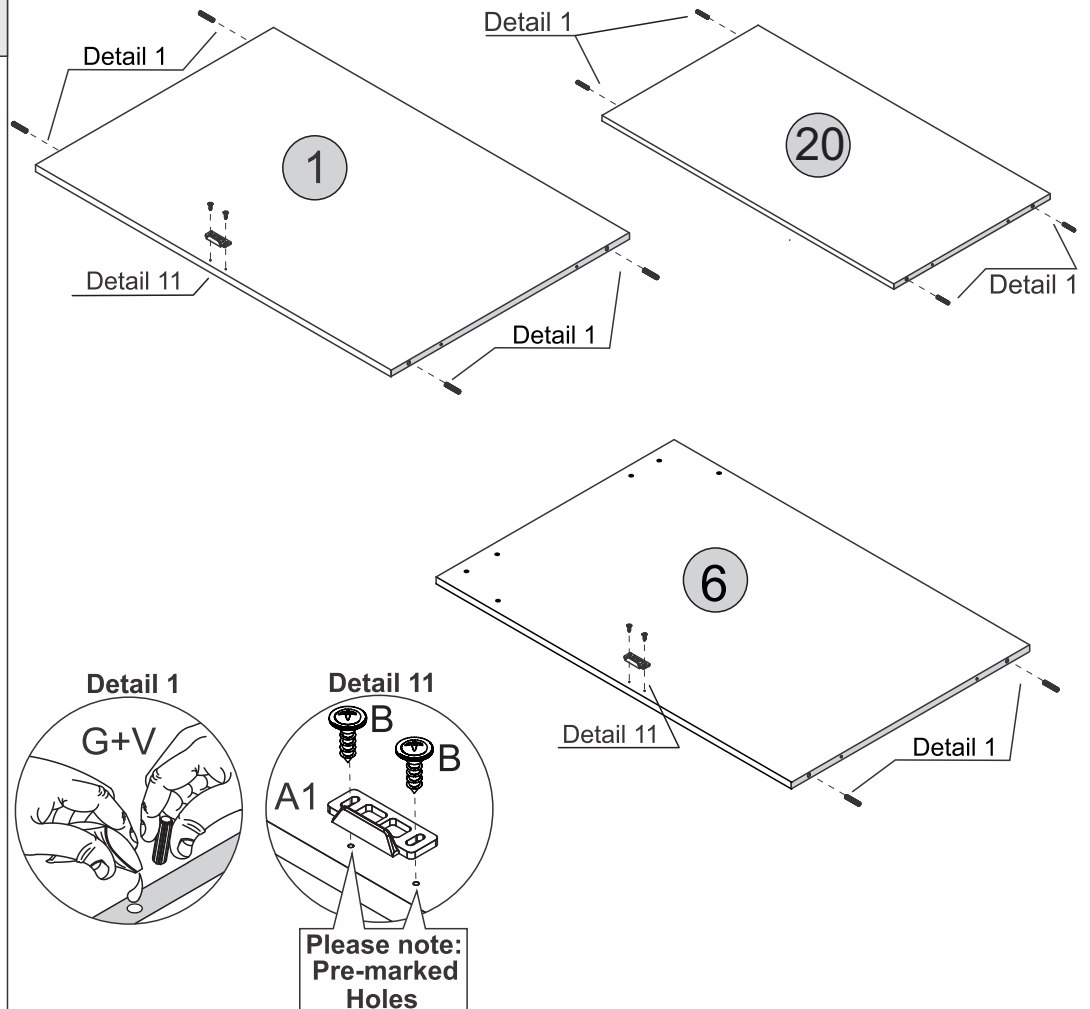
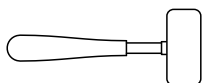
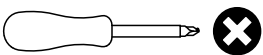

STEP 9

PARTS REQUIRED

2 - TOP PANEL x1

HARDWARE REQUIRED

B  04
Ø3,5 x 12mm

G  04
Ø6,0 x 30mm

J  04

V  01

Z  04
Ø4,0 x 12mm

A1  02

TOOLS REQUIRED

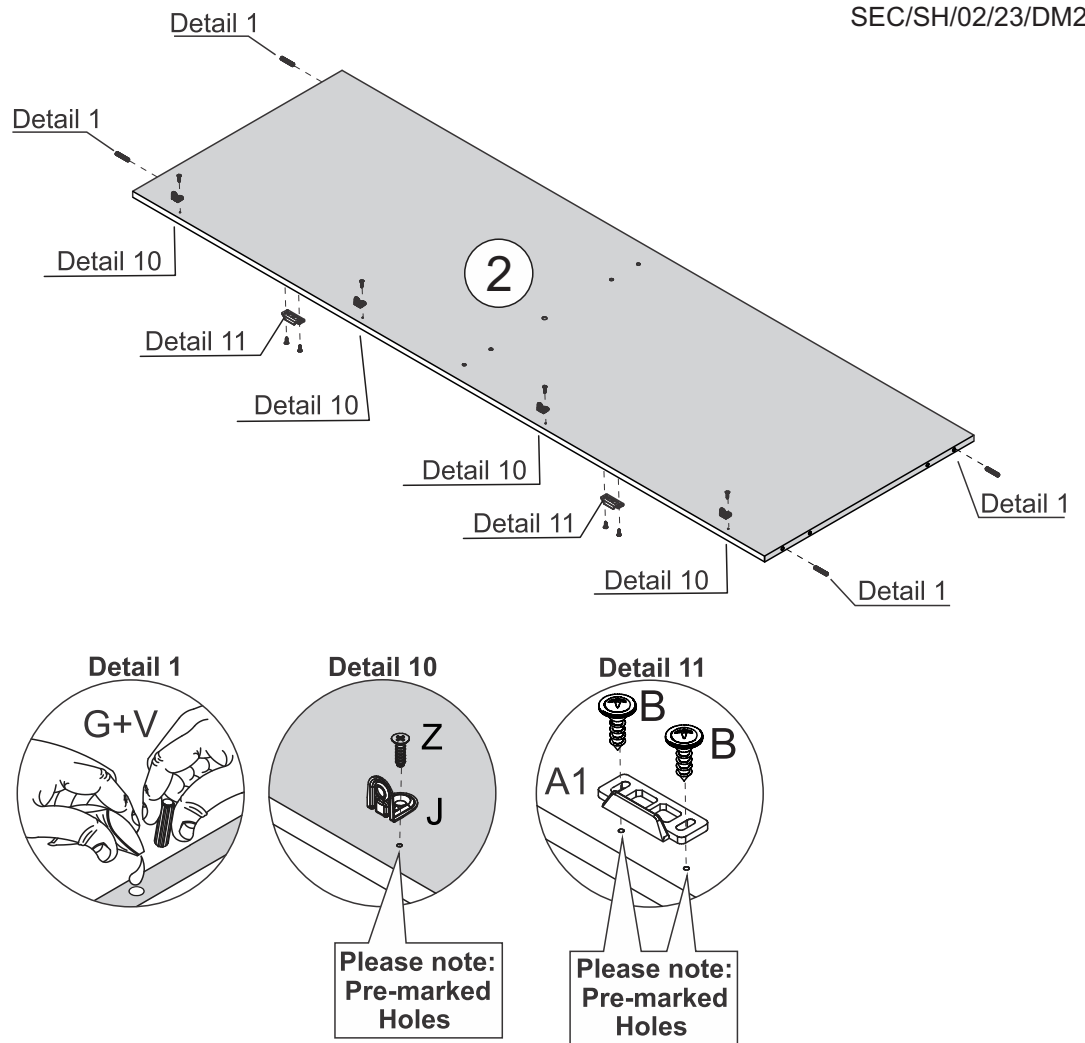
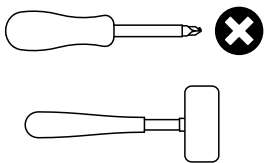

STEP 10

PARTS REQUIRED

1 - DRAWER TOP x1

2 - TOP PANEL x1

3 - DIVISION PANEL x1

6 - BASE PANEL x1

HARDWARE REQUIRED

F  06
Ø4,0 x 45mm

V  01

TOOLS REQUIRED

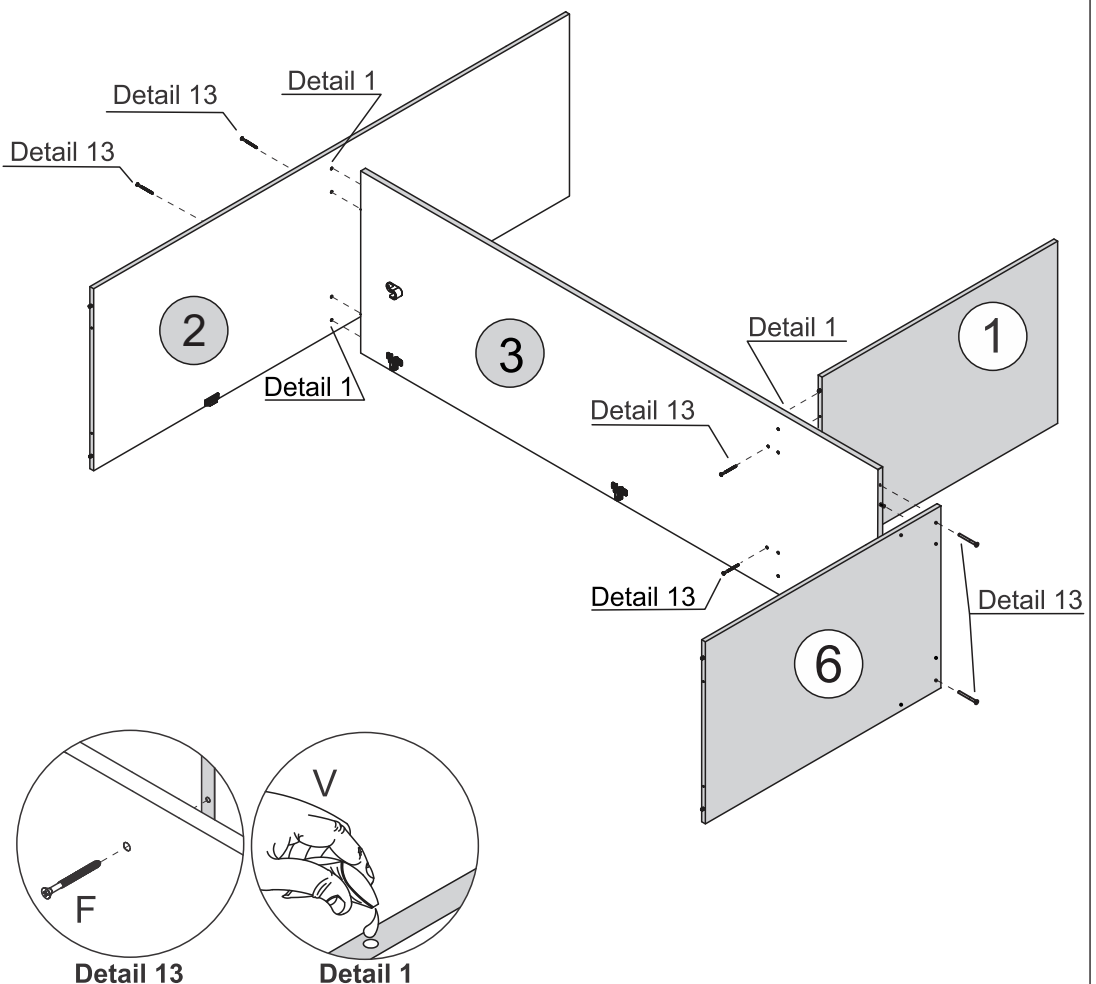
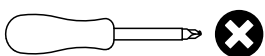

STEP 11

PARTS REQUIRED

4 - LEFT SIDE PANEL x1

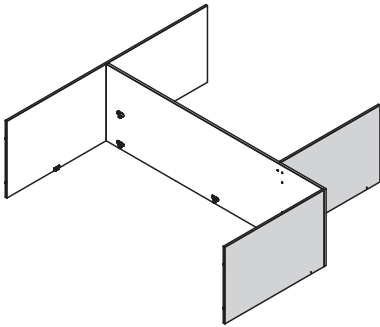

HARDWARE REQUIRED

F  Ø4,0 x 45mm 04

V  01

TOOLS REQUIRED

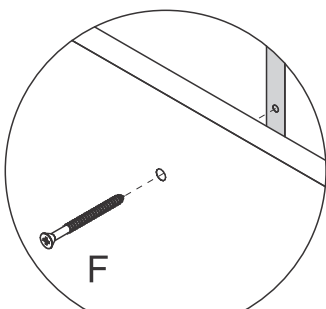
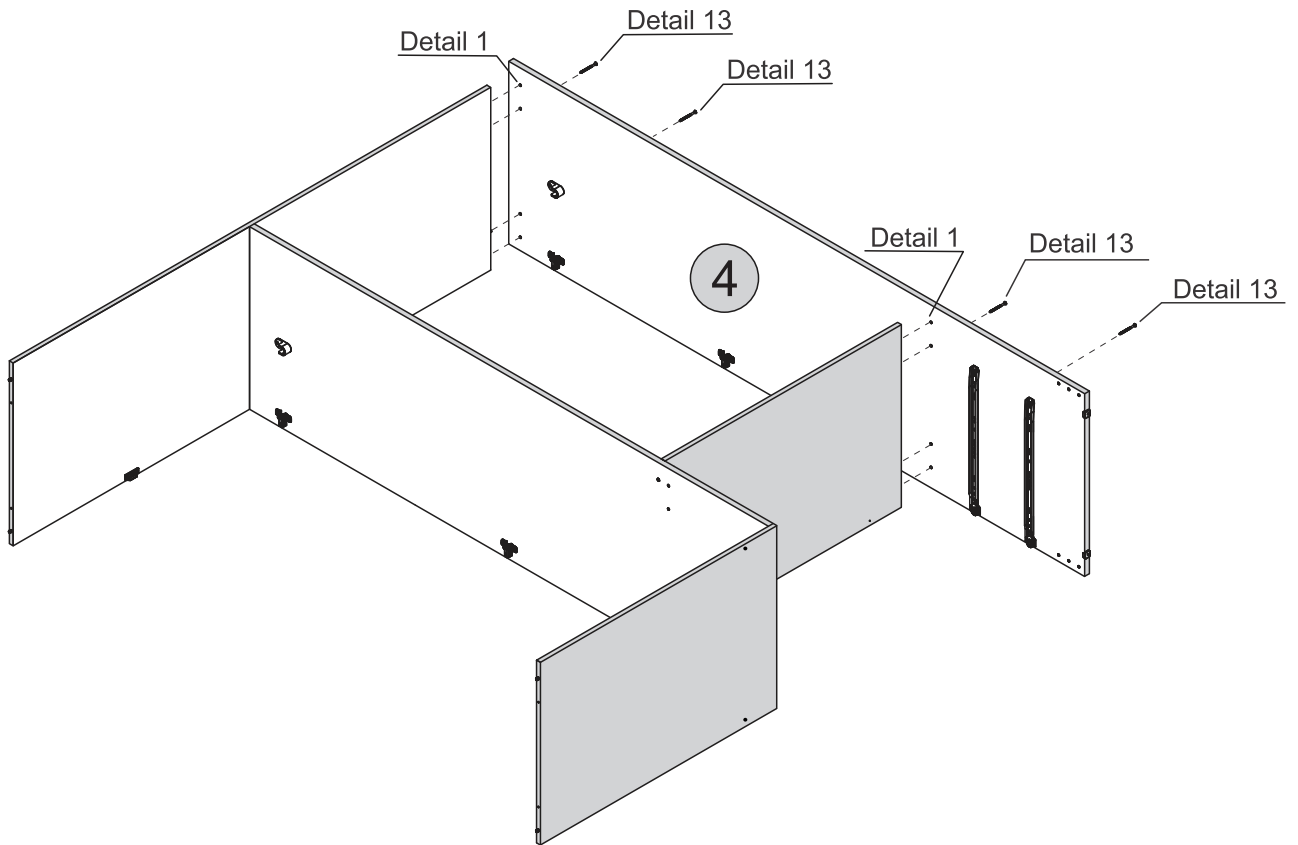
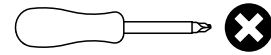

Detail 13

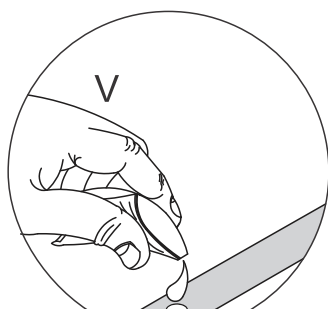



Detail 1

STEP 12

PARTS REQUIRED

5 - RIGHT SIDE PANEL	x1
7 - FRONT BASEBOARD	x1
8 - BACK BASEBOARD	x1
20 - SHELF	x1

HARDWARE REQUIRED

F	 Ø4.0 x 45mm	14
V	 Glue	01

TOOLS REQUIRED

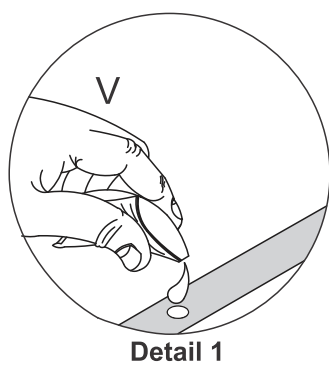
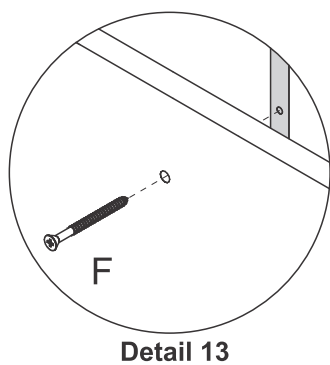
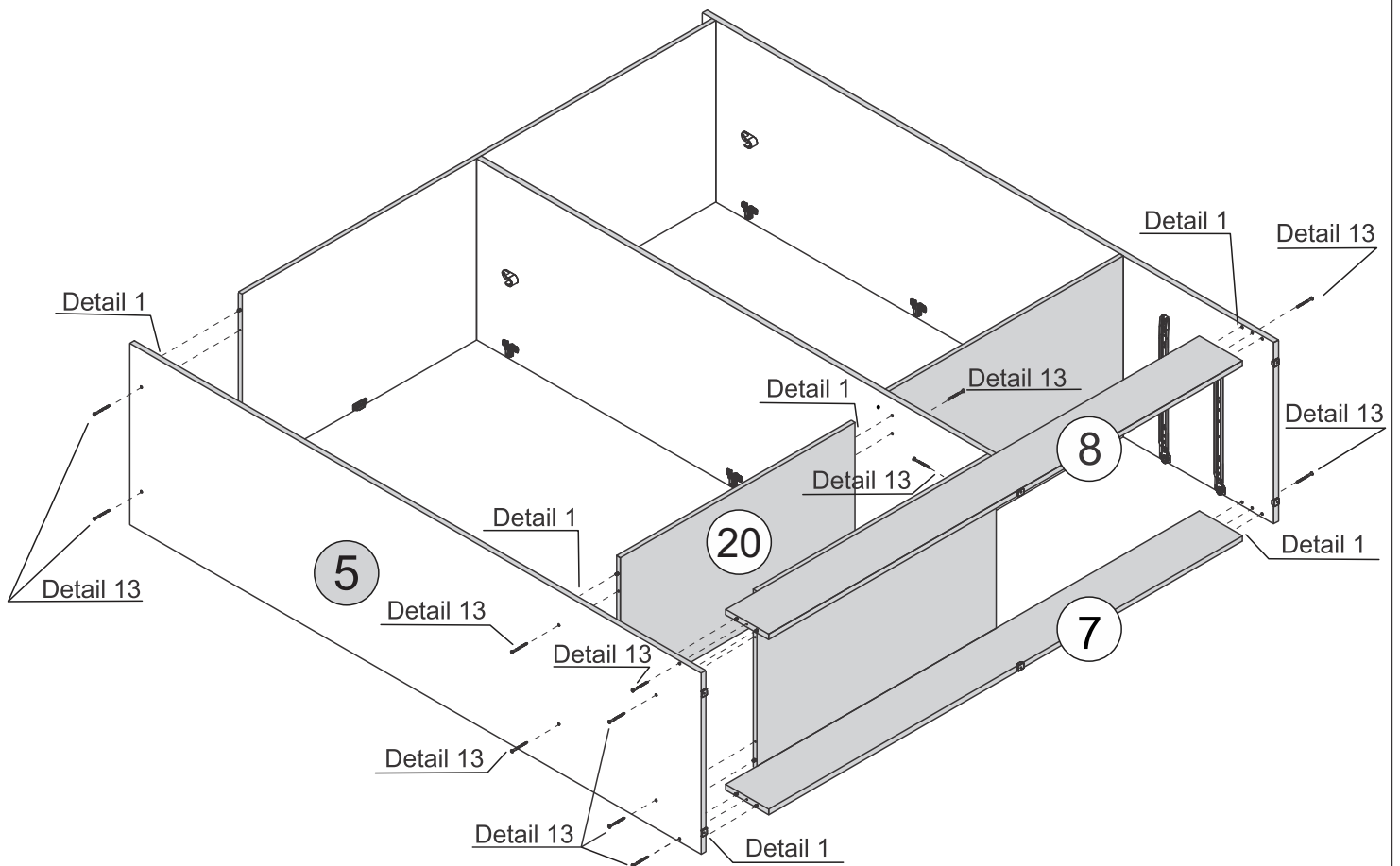
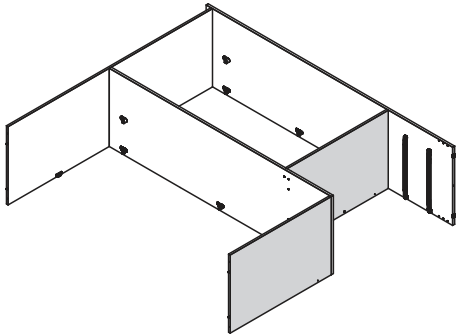
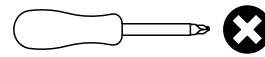

STEP 13

PARTS REQUIRED

9 - BACK PANEL x4

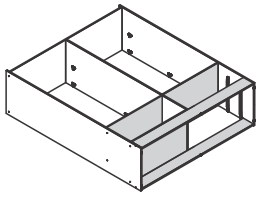

HARDWARE REQUIRED

H  10 x 10 62

I  14

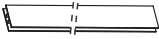
R  02

TOOLS REQUIRED

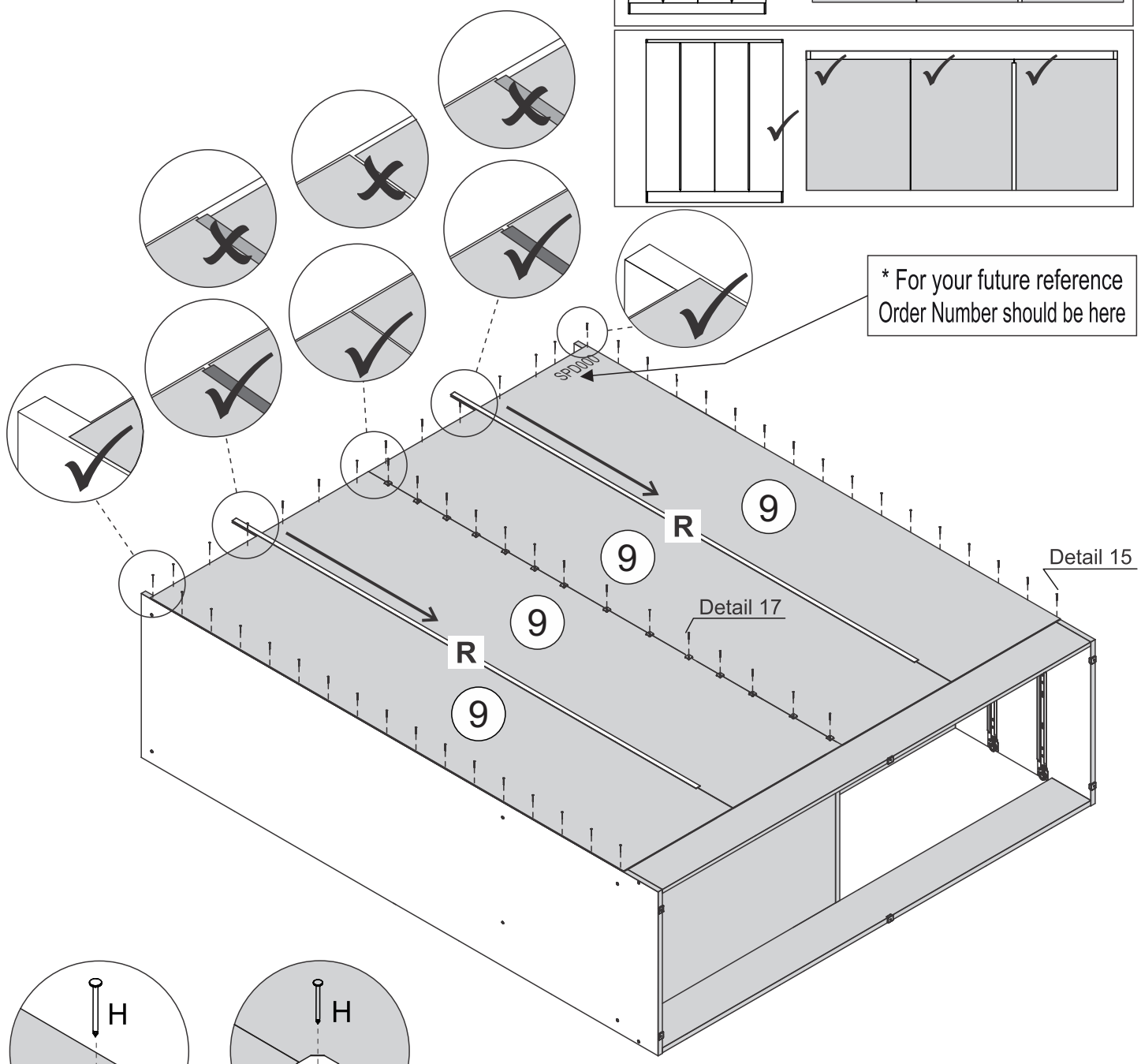
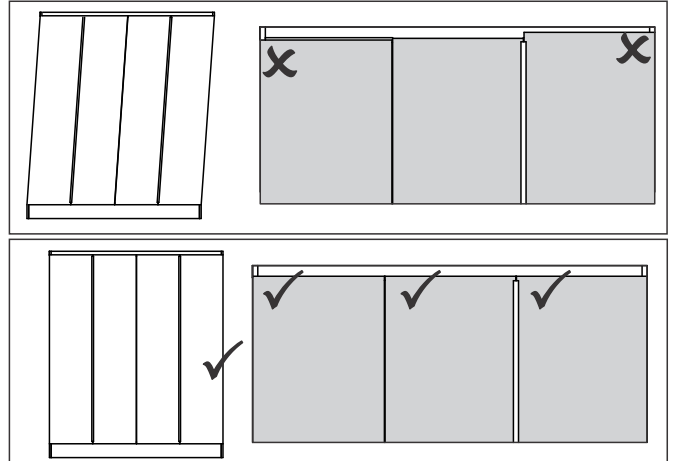
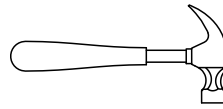

* For your future reference
Order Number should be here

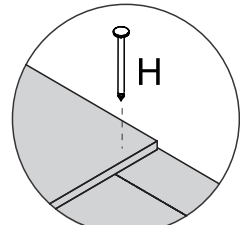

Detail 15

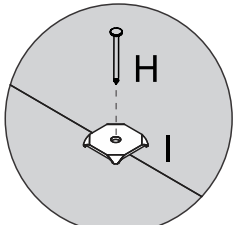

Detail 17

STEP 14

PARTS REQUIRED

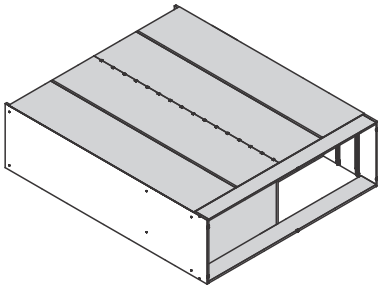

HARDWARE REQUIRED

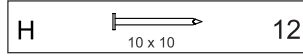

TOOLS REQUIRED

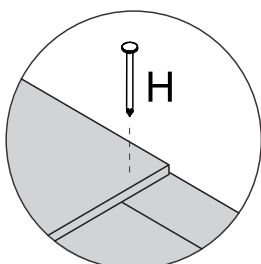
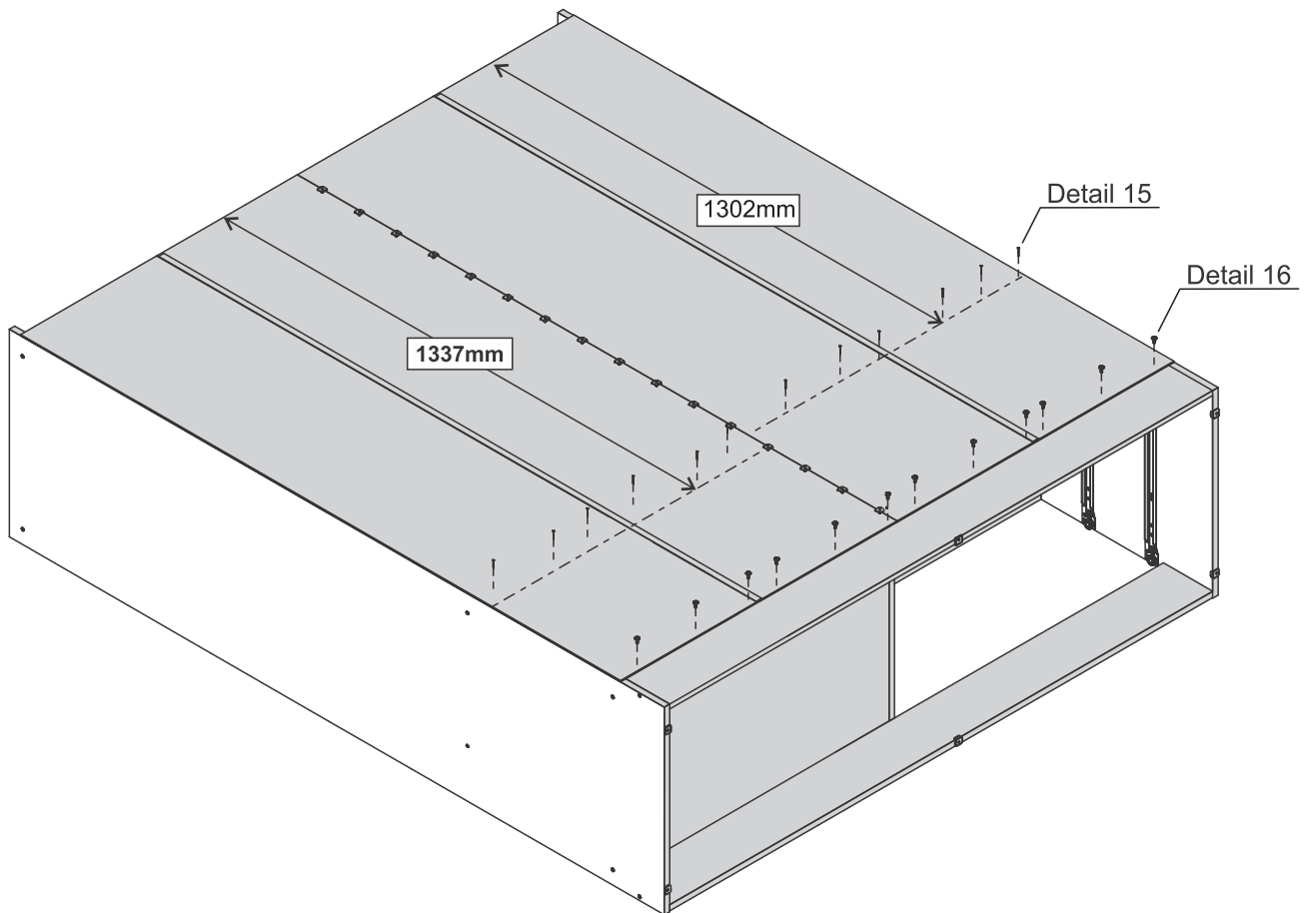
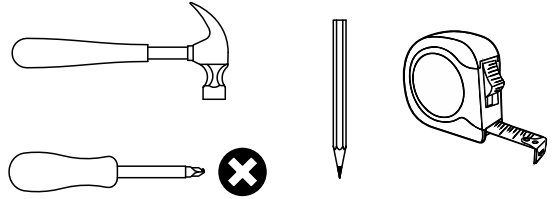

Detail 15

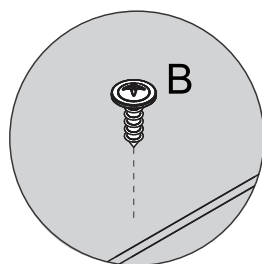

Detail 16

STEP 15

PARTS REQUIRED

10 - FRAME x1

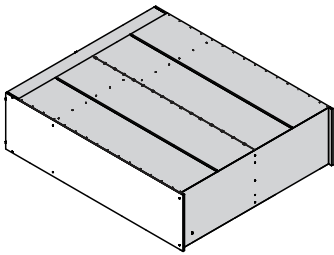

HARDWARE REQUIRED

J  02

Z  08
Ø4.0 x 12mm

TOOLS REQUIRED

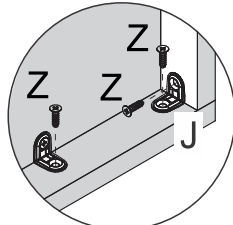
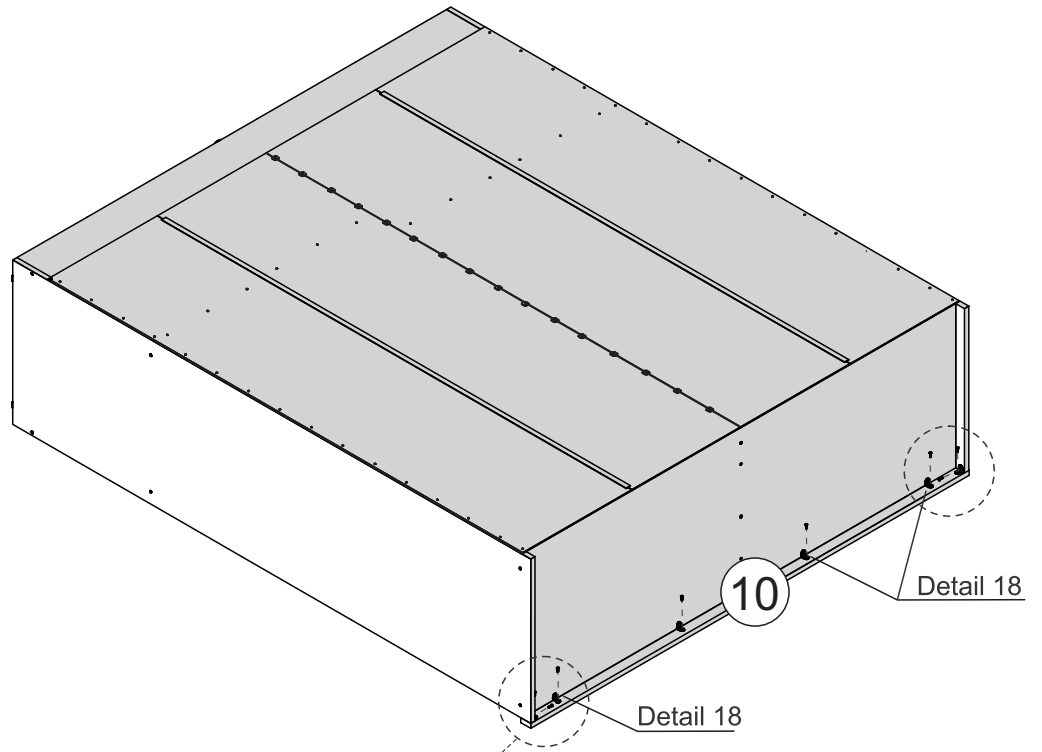
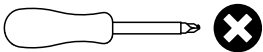

Detail 18

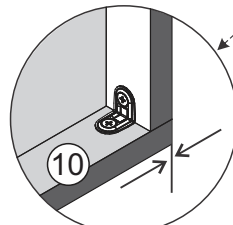

Align corners

STEP 16

PARTS REQUIRED

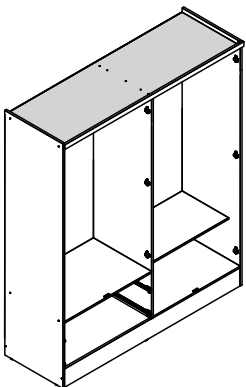

HARDWARE REQUIRED

Y  02

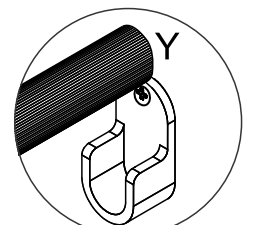
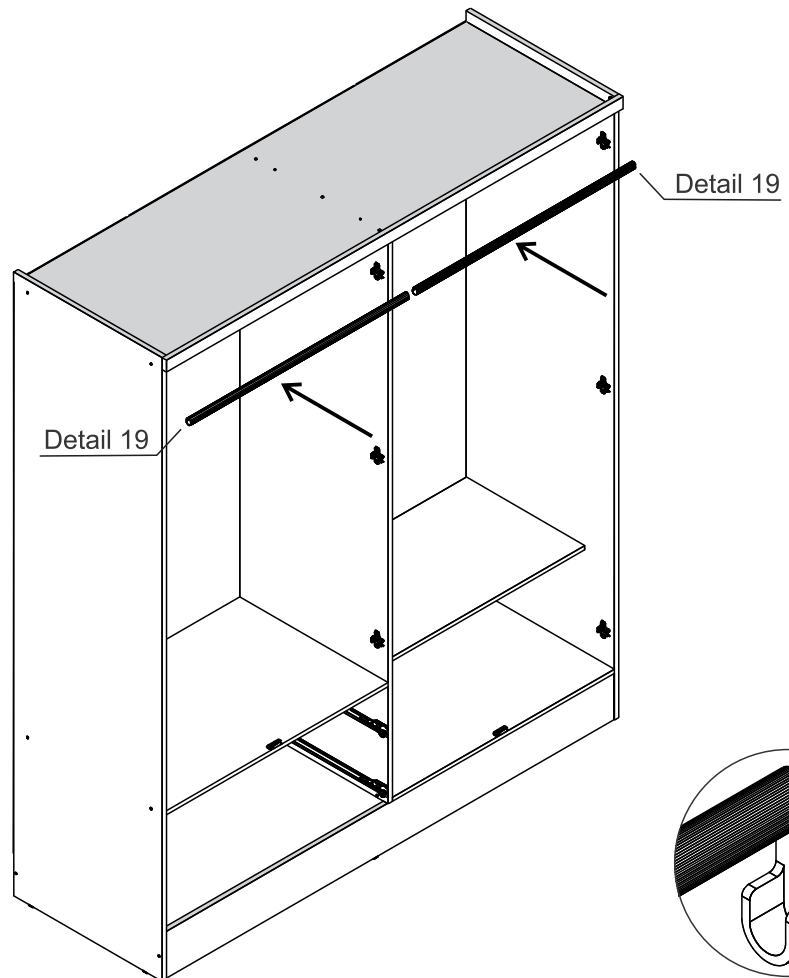

Detail 19

STEP 17

PARTS REQUIRED

15 - DRAWER SIDE x4

16 - DRAWER BACK PANEL x2

17 - DRAWER FRONT x2

19 - DRAWER BOTTOM SUPPORT BAR x2

HARDWARE REQUIRED

G  20
Ø6,0 x 30mm

V  01

X  04

TOOLS REQUIRED

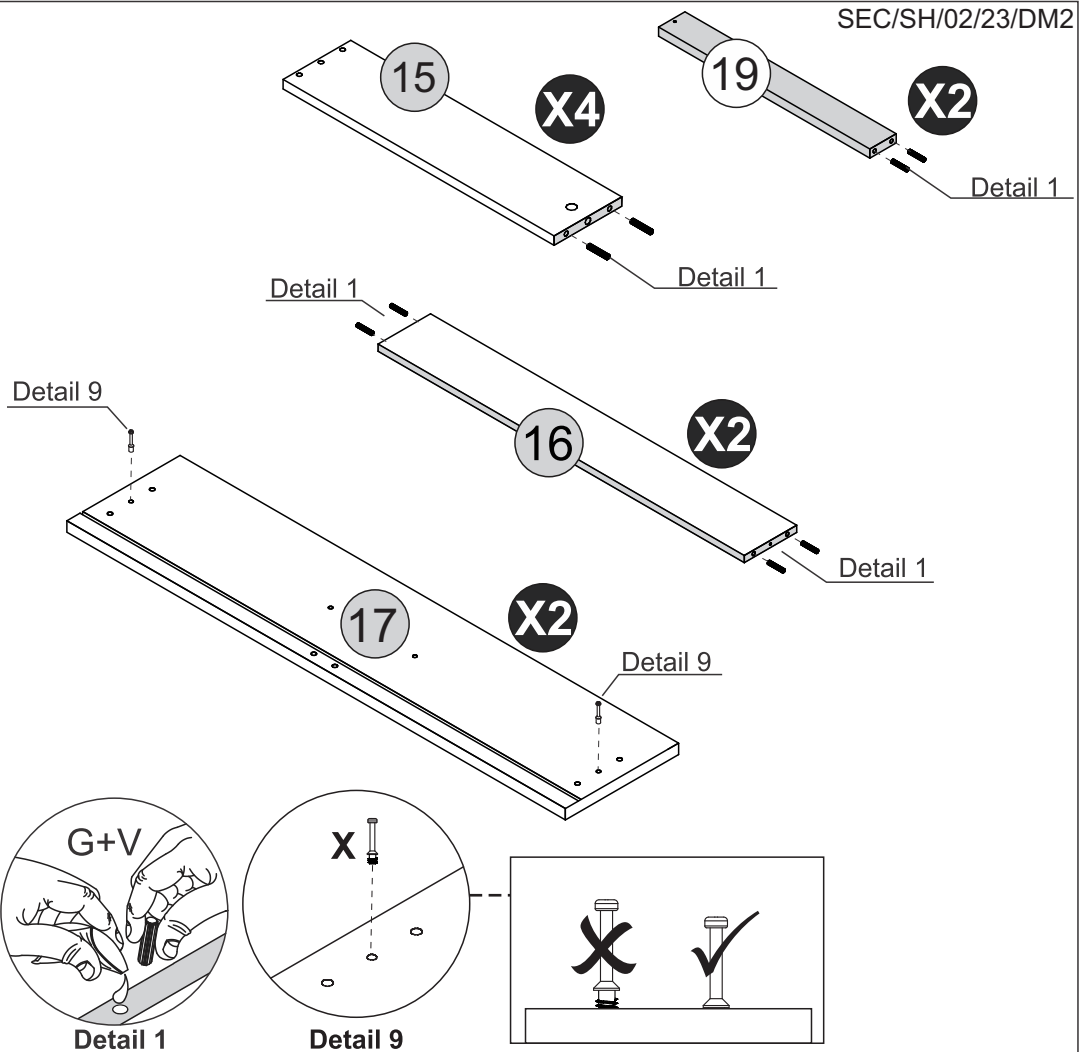
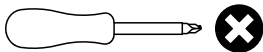

STEP 18

PARTS REQUIRED

15 - DRAWER SIDE x4

16 - DRAWER BACK PANEL x2

HARDWARE REQUIRED

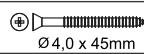
F  04
Ø4,0 x 45mm

TOOLS REQUIRED

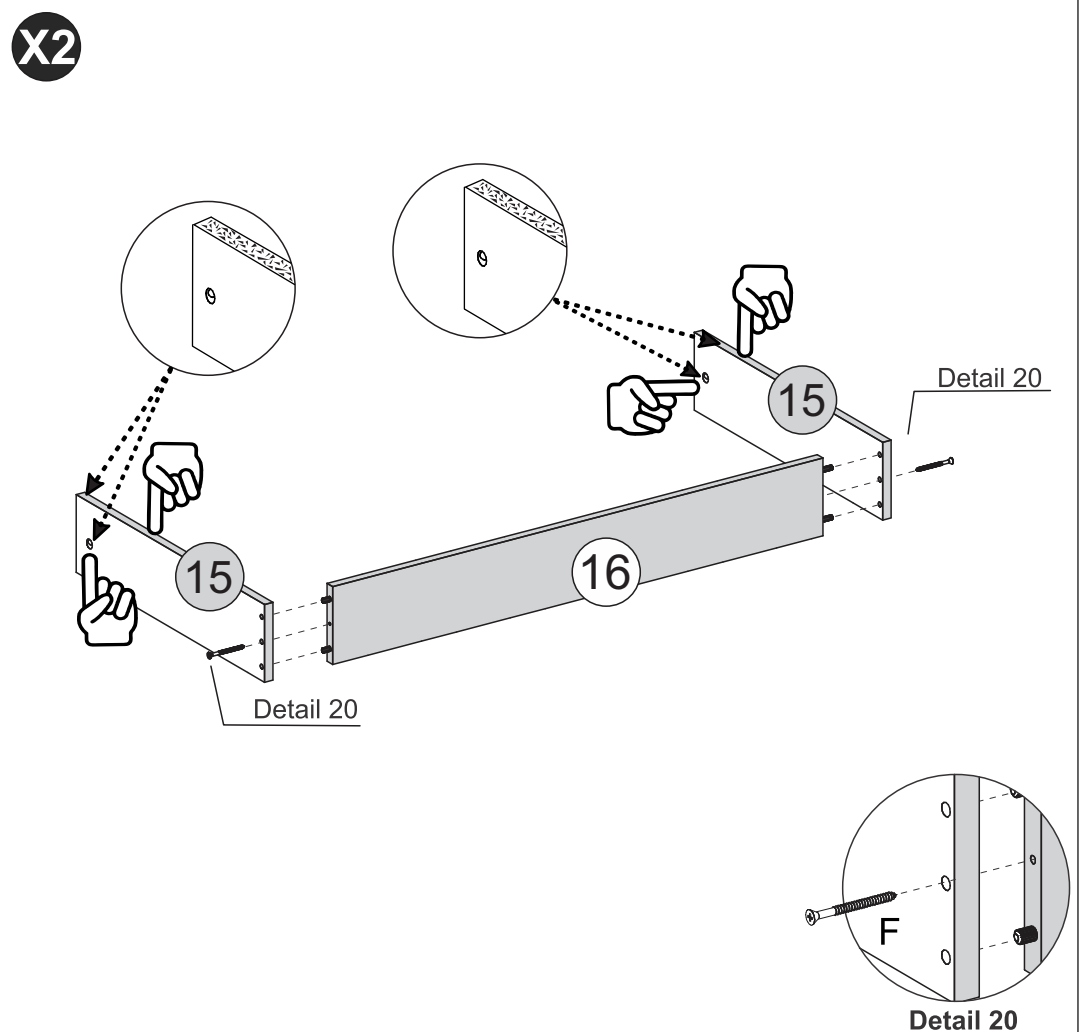
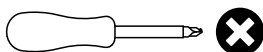

STEP 19

PARTS REQUIRED

17 - DRAWER FRONT x2

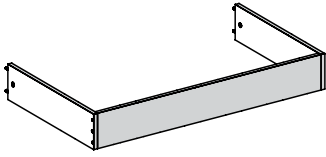

HARDWARE REQUIRED

V  01

TOOLS REQUIRED

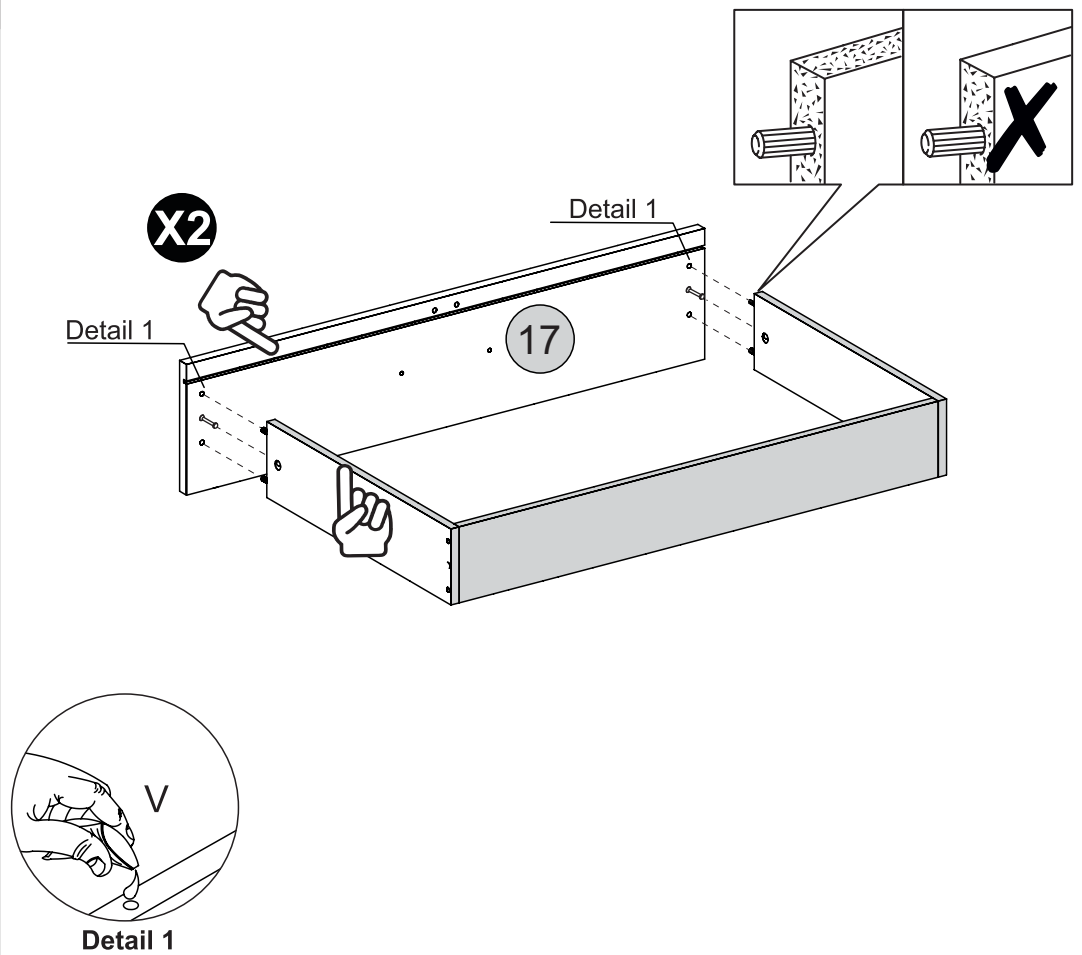

STEP 20

PARTS REQUIRED

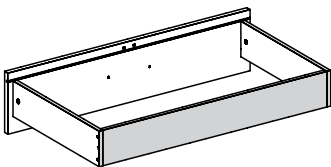

HARDWARE REQUIRED

U  08

W  04

TOOLS REQUIRED

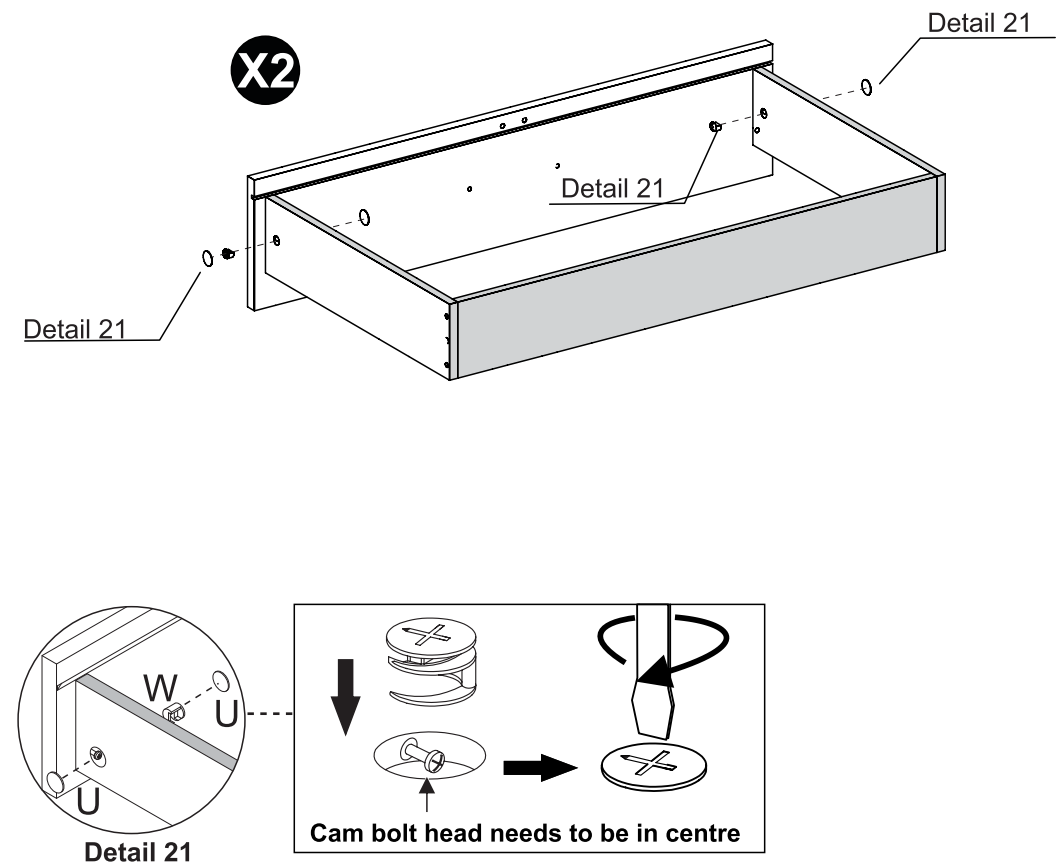
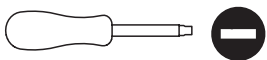

STEP 21

PARTS REQUIRED

18 - DRAWER BOTTOM x2

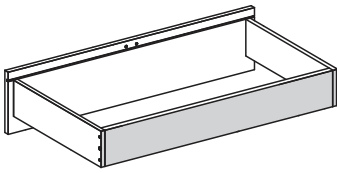

HARDWARE REQUIRED

H  08

TOOLS REQUIRED

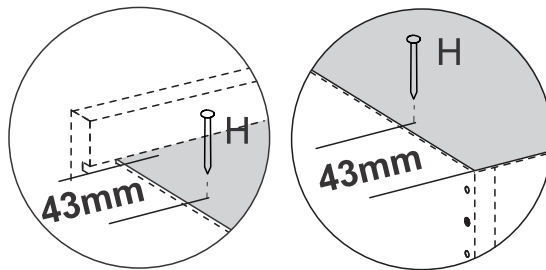
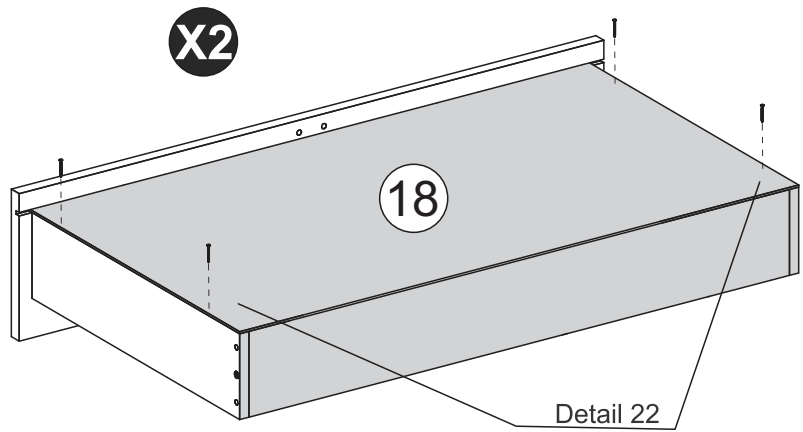
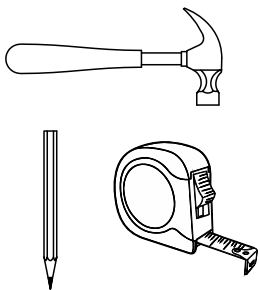

Detail 22

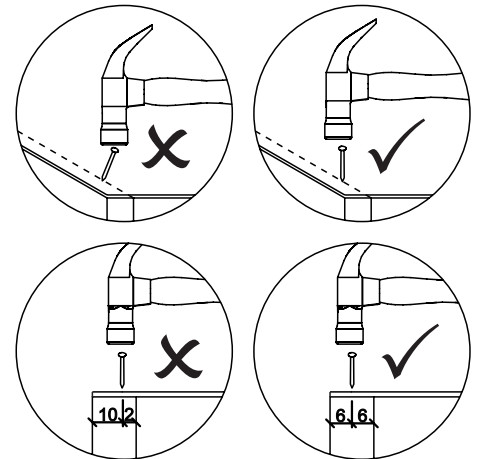

STEP 22

PARTS REQUIRED

19 - DRAWER BOTTOM SUPPORT BAR x2

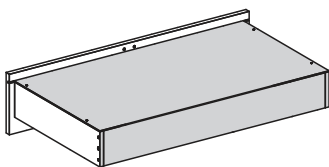

HARDWARE REQUIRED

H  12

V  01

TOOLS REQUIRED

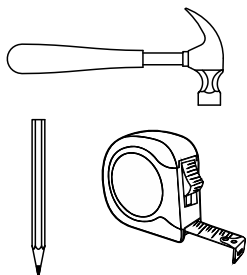

X2

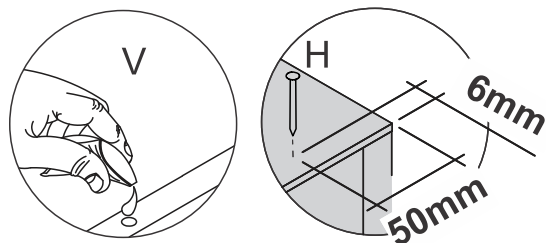
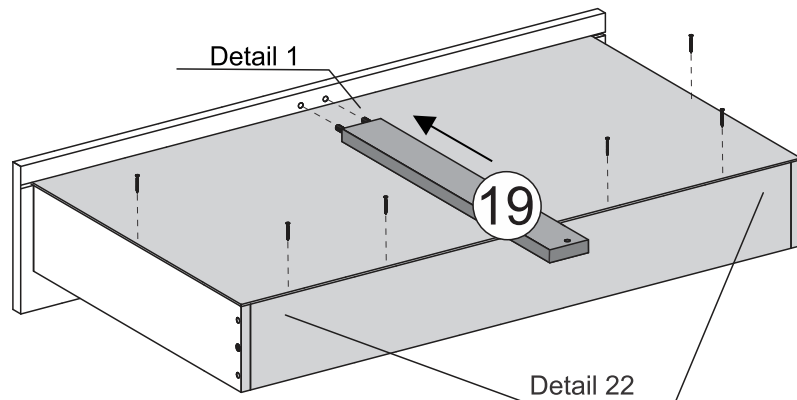

Detail 1

Detail 22

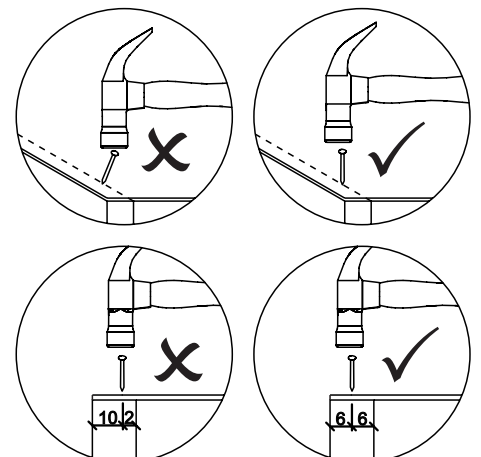

STEP 23

PARTS REQUIRED

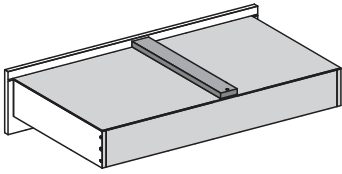

HARDWARE REQUIRED

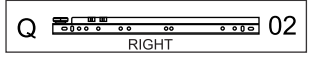
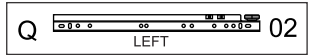
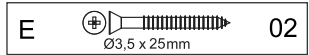
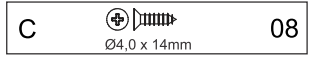

TOOLS REQUIRED

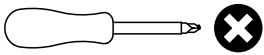

X2

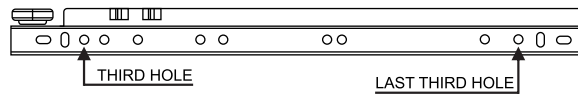
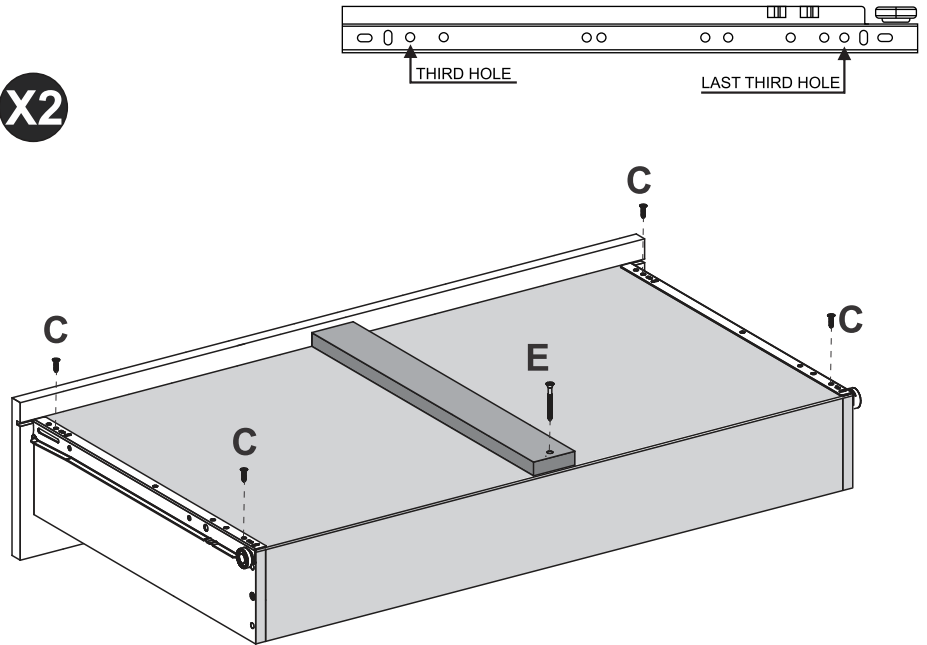

STEP 24

PARTS REQUIRED

11 - RIGHT LARGE DOOR	x1
-----------------------	----

12 - LEFT LARGE DOOR	x1
----------------------	----

13 - RIGHT SMALL DOOR	x1
-----------------------	----

14 - LEFT SMALL DOOR	x1
----------------------	----

HARDWARE REQUIRED

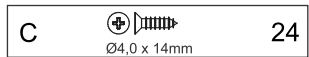

TOOLS REQUIRED

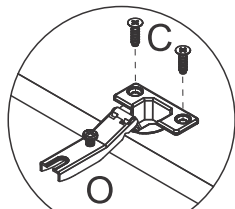
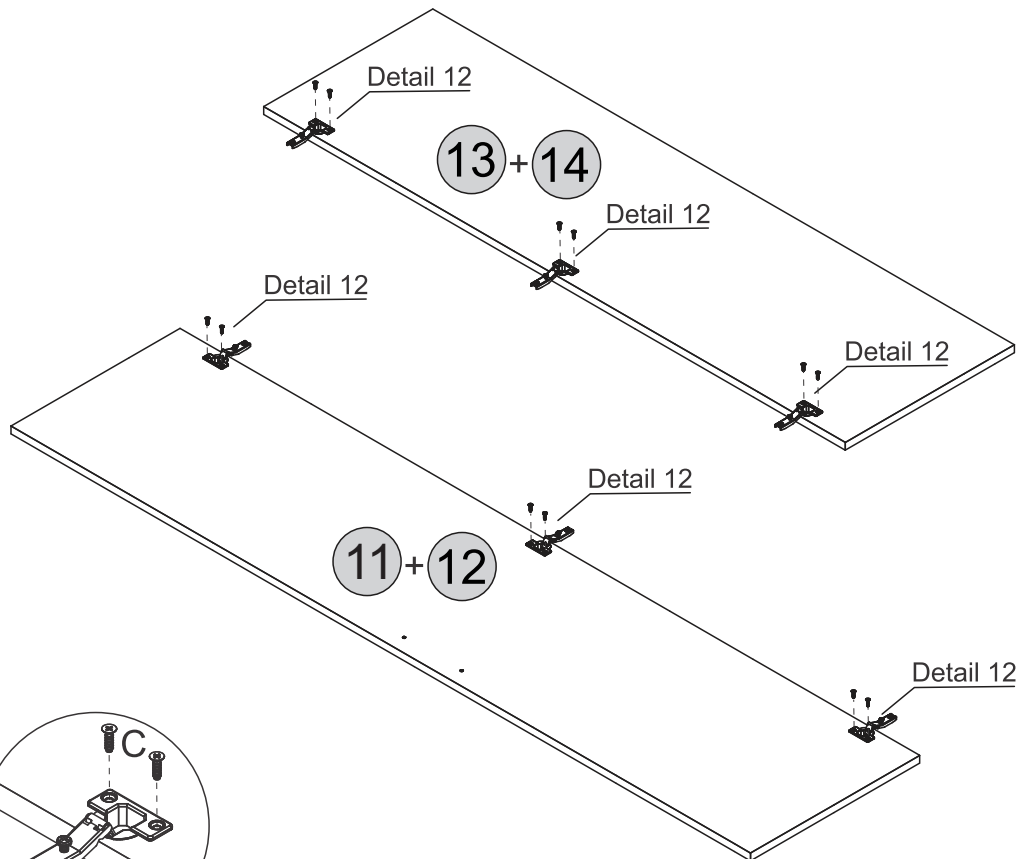
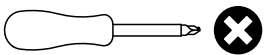

Detail 12

STEP 25

PARTS REQUIRED

- 11 - RIGHT LARGE DOOR x1
- 12 - LEFT LARGE DOOR x1
- 13 - RIGHT SMALL DOOR x1
- 14 - LEFT SMALL DOOR x1

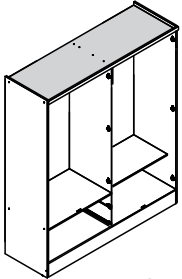

HARDWARE REQUIRED

- U  20

TOOLS REQUIRED

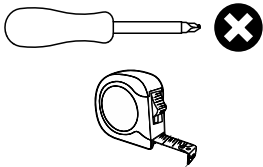

!
Please note the top or bottom edges of the doors are labelled LEFT or RIGHT to make them easier to identify when assembling.

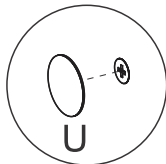
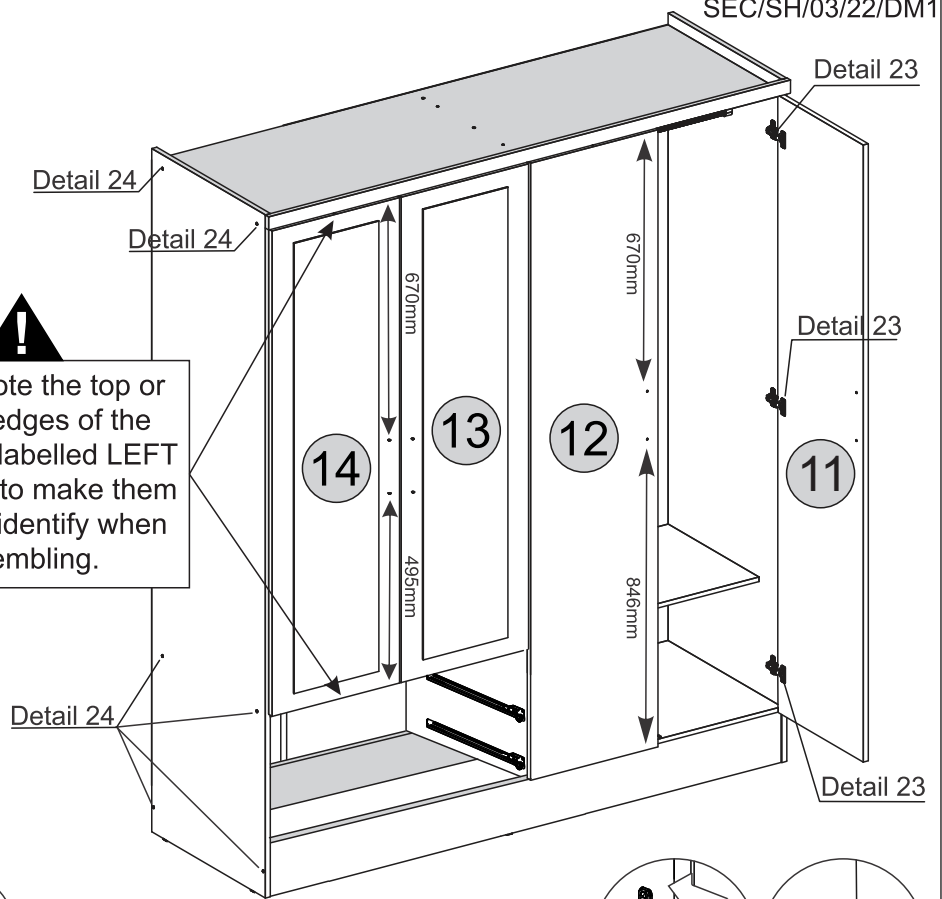

Detail 24

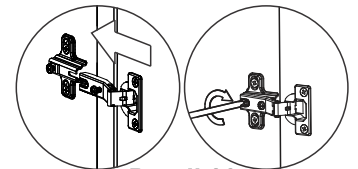



Detail 23

STEP 26

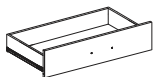
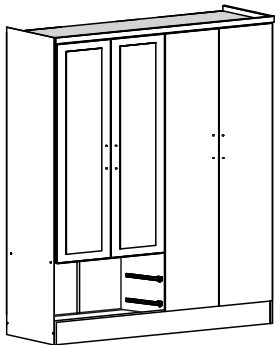
PARTS REQUIRED



HARDWARE REQUIRED

- D  12
Ø4,0 x 20mm
- T  06

TOOLS REQUIRED

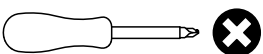

TIP
If desired, after assembly use an alcohol cleaner to erase the number printed on the parts.

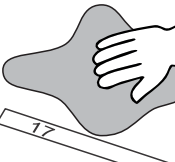

!
See the last page

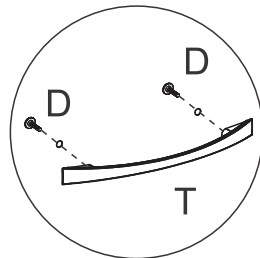
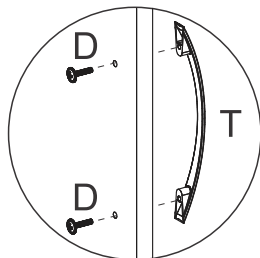

Detail 25

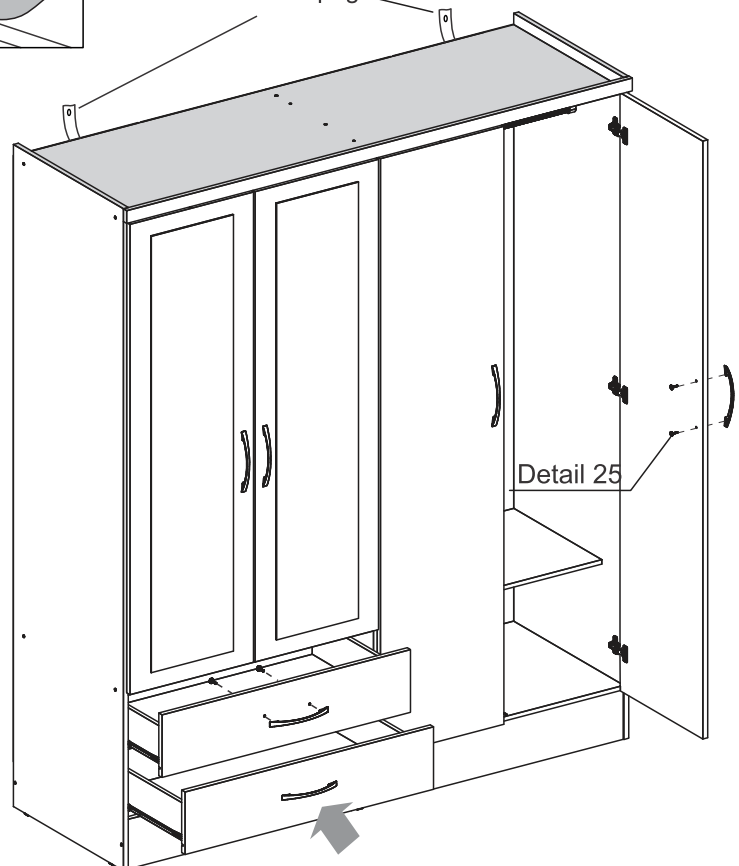

STEP 27

PARTS REQUIRED

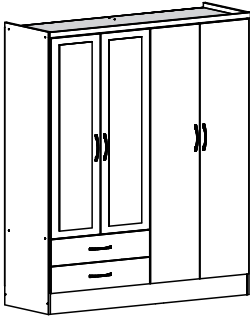

HARDWARE REQUIRED

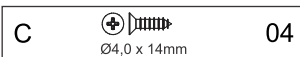

TOOLS REQUIRED

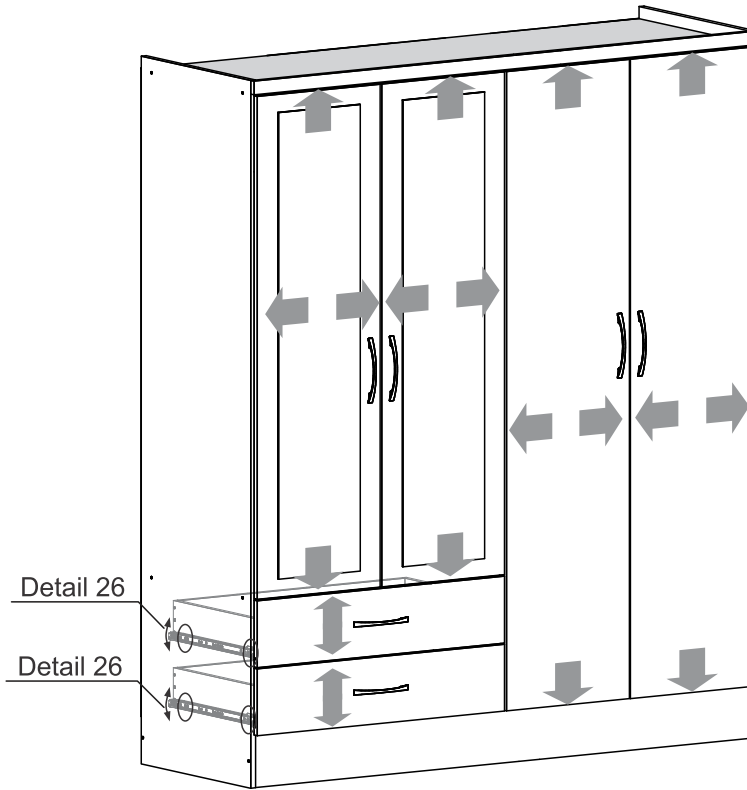
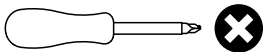

Detail 26

Detail 26

Drawer Adjustment

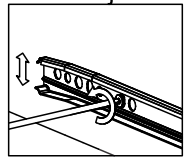

Drawer Lock

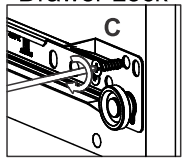

Detail 26

Height Adjustment

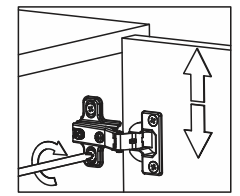

Internal Adjustment

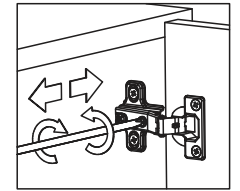

Depth Adjustment

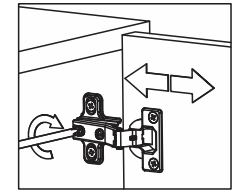
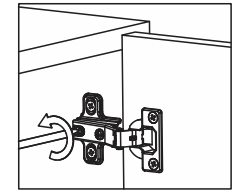

WARNING

Serious or fatal injuries can occur from furniture tipping over. To prevent the furniture from tipping over we recommend that it is permanently fixed to the wall.

Wall fixings are not supplied with this product as different wall materials require different types of fixing devices.

Please make sure you use fixings suitable for the walls in your home.

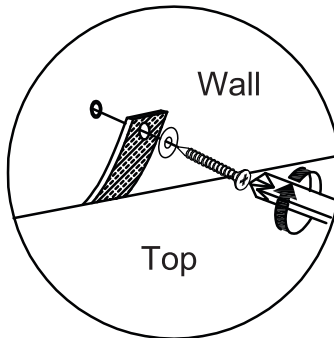
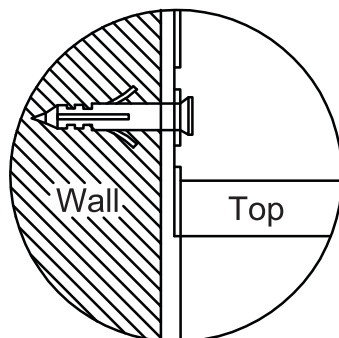
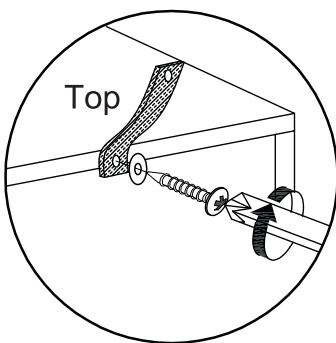

	N Flan Head Screw Ø3,5 x 30mm (2x)
	K Washer (4x)
	S Strap (2x)