

# NEVADA 3 DOOR 2 DRAWER WARDROBE ASSEMBLY INSTRUCTIONS

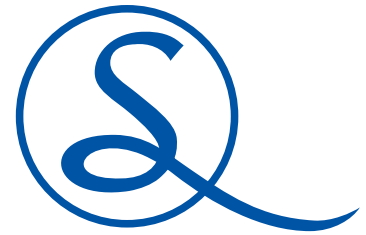

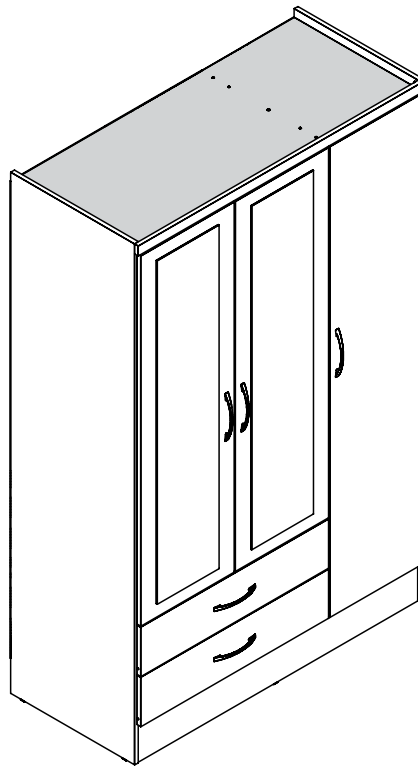

## **IMPORTANT FOR DOMESTIC USE ONLY PLEASE READ BEFORE YOU CONTINUE FURTHER CARE AND MAINTENANCE**

After unpacking this product please keep the original packaging in case it needs to be returned for any reason.

- Please ensure all fittings and parts are present before commencing with assembly.
- Never drag or push products as this could cause damage to the joints making it inferior.
- We strongly recommend that you keep children away from your work area.
- We recommend that you lay a blanket or sheet on the floor to avoid damage to both your floor and the product.
- Assemble this product as close to its final position as possible.
- Do not place this product next to a radiator or in direct sunlight.
- Do not drag or push items across your high gloss furniture as this may cause the surface to scratch
- Wood is a natural product and may expand if subjected to damp and may shrink or crack if subjected to heat. Therefore it is recommended that room temperature is maintained, with no sudden temperature fluctuations.
- Make sure any spillage is wiped off immediately.
- Do not place hot or chilled items directly on to the surface, use a place mat or marking will occur.
- For general cleaning use a soft cotton or micro fibre cloth, and do not use detergents of any kind.
- From time to time it may be necessary to tighten fittings, regular inspections should be carried out.
- Do not place on a wet or damp floor as staining may occur to your floor.

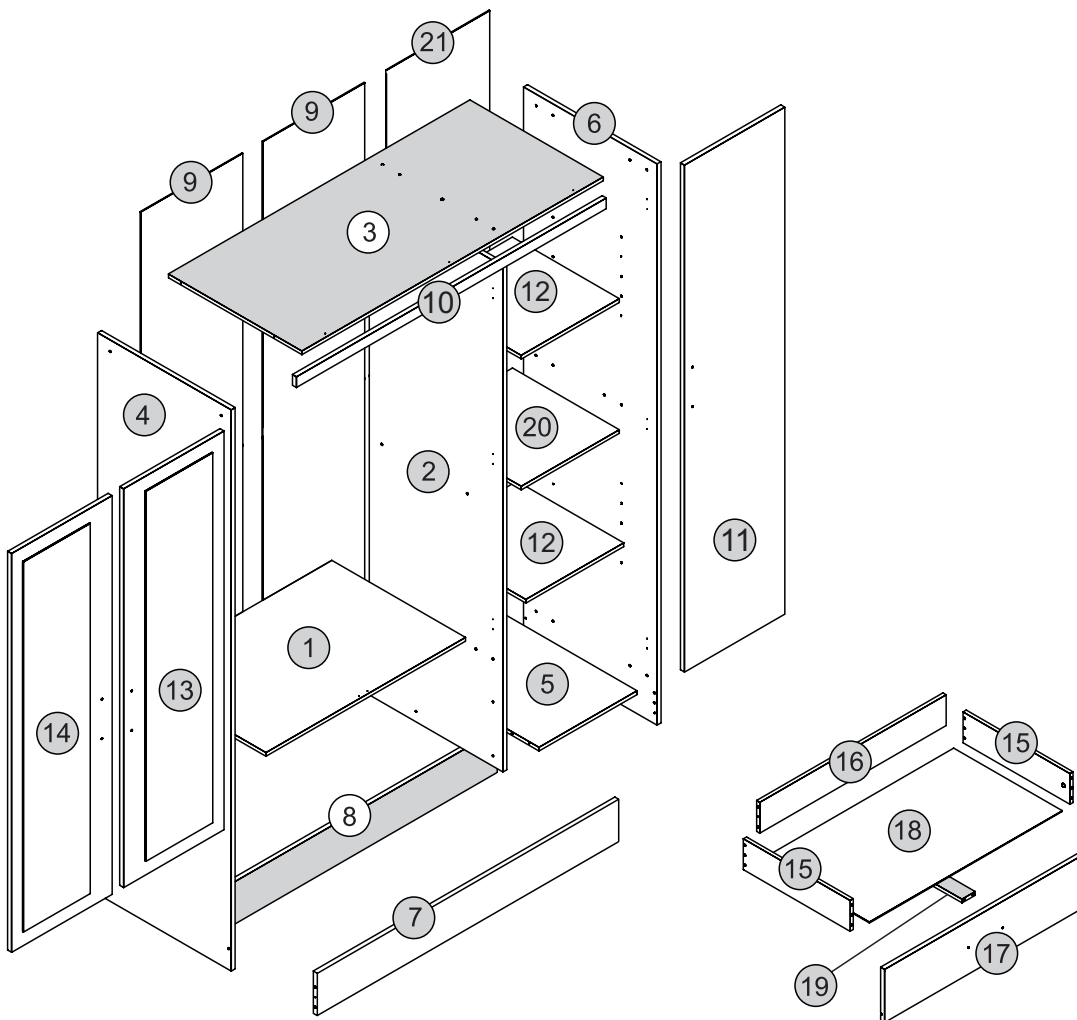
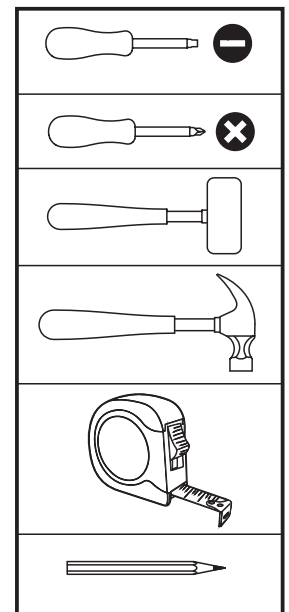
## TOOLS REQUIRED











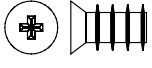
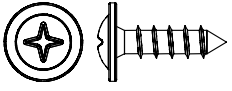

## PARTS LIST

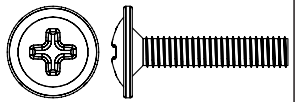
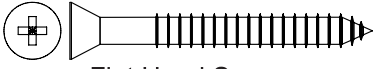
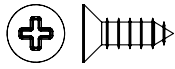
***Please Note:***

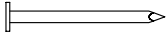
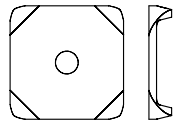
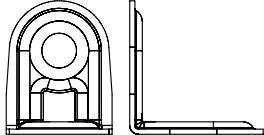
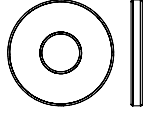
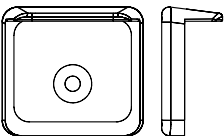
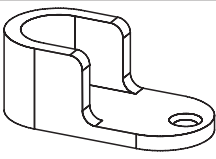
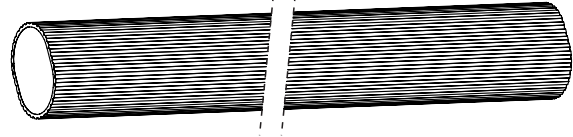
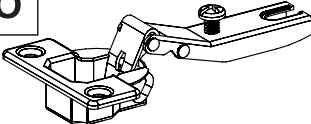
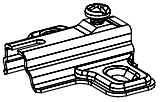
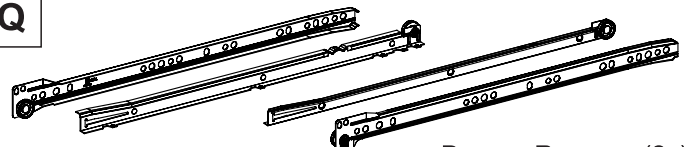
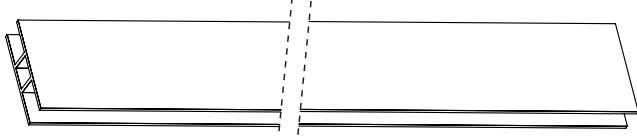
The below parts have all been stamped with the part number to help identify them during assembly.

<b>Part Number</b>	<b>Part Description</b>	<b>Quantity</b>	<b>Carton</b>
1	Large Base Panel	1	2/3
2	Division Panel	1	1/3
3	Top Panel	1	2/3
4	Left Side Panel	1	1/3
5	Small Base Panel	1	2/3
6	Right Side Panel	1	1/3
7	Front Baseboard	1	2/3
8	Back Baseboard	1	2/3
9	Small Back Panel	2	3/3
10	Frame	1	2/3
11	Large Door	1	3/3
12	Movable Shelf	2	2/3
13	Right Small Door	1	3/3
14	Left Small Door	1	3/3
15	Drawer Side	4	2/3
16	Drawer Back Panel	2	2/3
17	Drawer Front	2	2/3
18	Drawer Bottom	2	1/3
19	Drawer Bottom Support Bar	2	2/3
20	Shelf	1	2/3
21	Large Back Panel	1	3/3

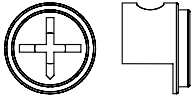
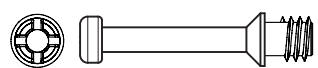
# FITTINGS LIST

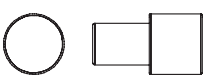
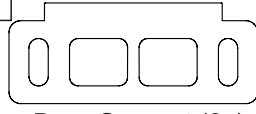
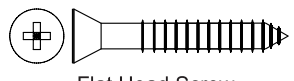
<p><b>A</b></p>  <p>Flat Head Screw Ø6,0 x 8mm (8x)</p> <p>1/+</p>	<p><b>B</b></p>  <p>Flan Head Screw Ø3,5 x 12mm (13x)</p> <p>2/+</p>	<p><b>C</b></p>  <p>Flat Head Screw Ø4,0 x 14mm (48x)</p> <p>2/+</p>	<p><b>D</b></p>  <p>Flan Head Screw Ø4,0 x 20mm (10x)</p> <p>2/+</p>
<p><b>E</b></p>  <p>Flat Head Screw Ø4,0 x 45mm(28x)</p> <p>2/+</p>	<p><b>F</b></p>  <p>Flat Head Screw Ø4,0 x 12mm (14x)</p> <p>2/+</p>		<p><b>G</b></p>  <p>2/+ Dowel Ø6,0 x 30mm (46x)</p>
<p><b>H</b></p>  <p>4/+ Nail 10 x 10 (86x)</p>	<p><b>I</b></p>  <p>2/+ Back Panel Bracket (14x)</p>	<p><b>J</b></p>  <p>1/+ 'L' Metallic Support (5x)</p>	<p><b>K</b></p>  <p>1/+ Washer (4x)</p>
<p><b>L</b></p>  <p>1/+ Plastic Foot (6x)</p>	<p><b>M</b></p>  <p>Hanging Rail Support (2x)</p>	<p><b>N</b></p>  <p>Hanging Rail (1x)</p>	
<p><b>O</b></p>  <p>Hinge (9x)</p>	<p><b>P</b></p>  <p>Hinge Plate (9x)</p>	<p><b>Q</b></p>  <p>Drawer Runners (2x)</p>	
<p><b>R</b></p>  <p>Back Panel Strip (1x)</p>		<p><b>S</b></p>  <p>Strap (2x)</p>	<p><b>T</b></p>  <p>Handle (5x)</p>
<p><b>U</b></p>  <p>2/+ Hole Plugs (30x)</p>	<p><b>V</b></p>  <p>Glue (2x)</p>	<p><b>W</b></p>  <p>1/+ Cam Nut (4x)</p>	<p><b>X</b></p>  <p>1/+ Cam Bolt (4x)</p>
<p><b>Y</b></p>  <p>Flan Head Screw Ø3,5 x 30mm (2x)</p> <p>1/+</p>	<p><b>Z</b></p>  <p>Support Pin (8x)</p> <p>1/+</p>	<p><b>A1</b></p>  <p>Door Support (2x)</p>	<p><b>A2</b></p>  <p>Flat Head Screw Ø3,5 x 25mm (2x)</p> <p>1/+</p>

## TIPS FOR FITTINGS CAM-LOCKS

WHEN FITTING CAM NUT, ENSURE STARTING POSITION IS CORRECT BEFORE YOU INSERT CONNECTING CAM BOLT TURN CLOCKWISE UNTIL SECURE

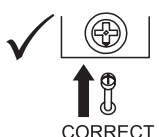

✓

CORRECT



✗

WRONG

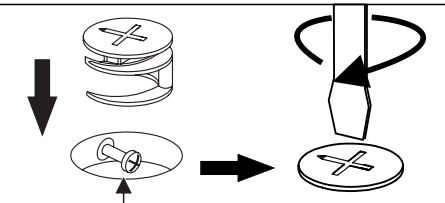

Cam bolt head needs to be in centre

### CAMBOLT

Tighten until shoulder in flush with panel. Do not overtighten or undertighten (see example beside)

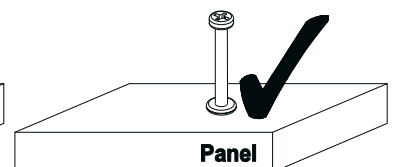
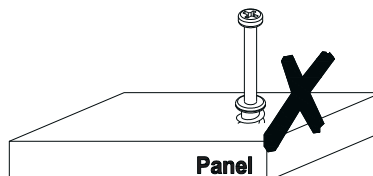
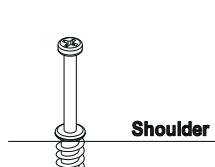

# STEP 1

## PARTS REQUIRED

2 - DIVISION PANEL x1

## HARDWARE REQUIRED

G  04  
Ø6,0 x 30mm

V  01  
Glue

Z  04

## TOOLS REQUIRED

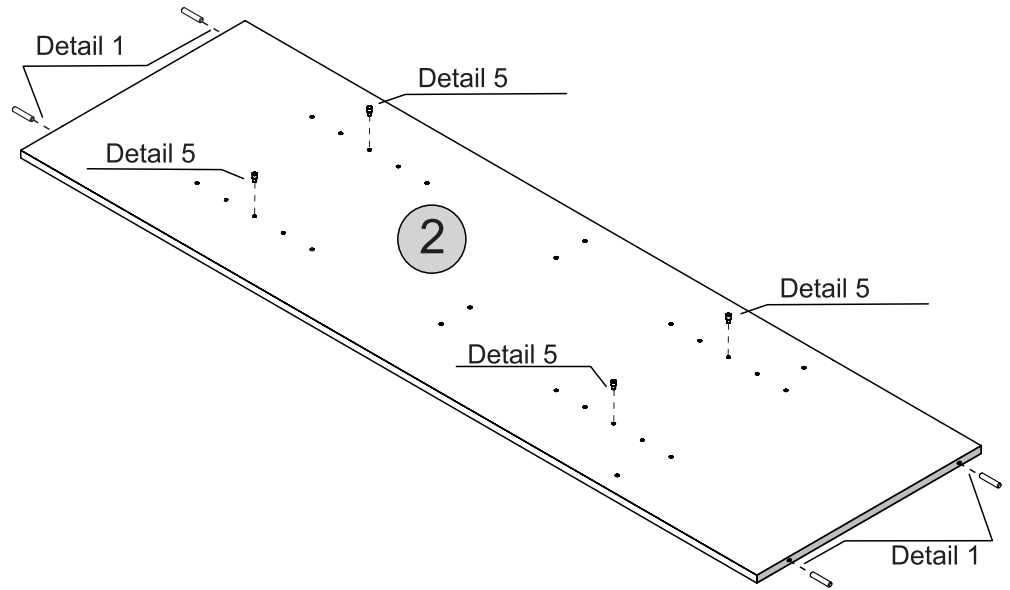
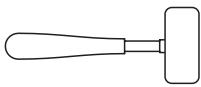

Detail 1

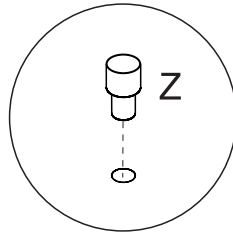

Detail 5

# STEP 2

## PARTS REQUIRED

2 - DIVISION PANEL x1

## HARDWARE REQUIRED

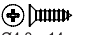
C  08  
Ø4,0 x 14mm

M  01

P  03

## TOOLS REQUIRED

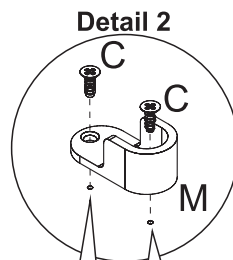
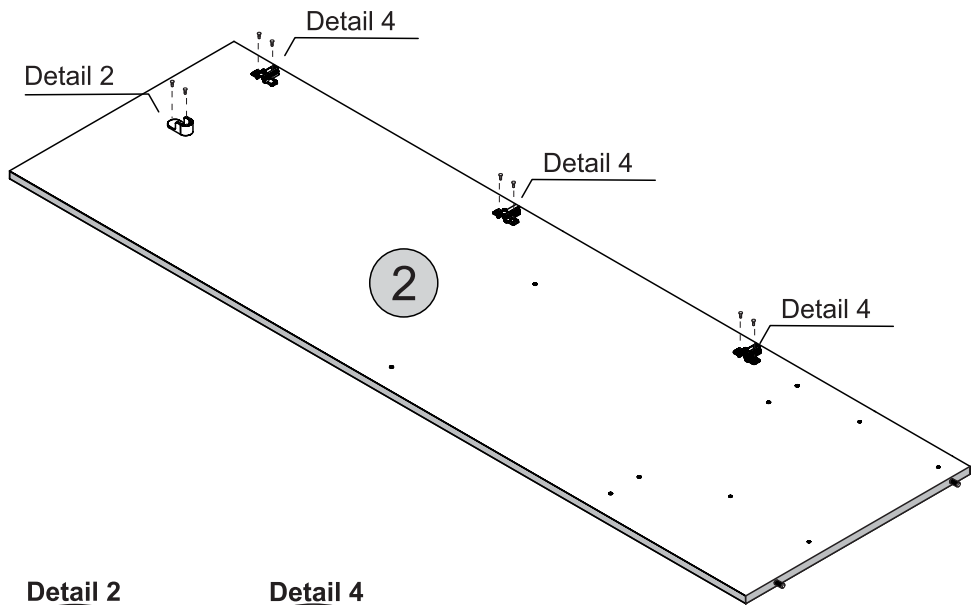
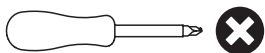

Please note:  
Pre-marked  
Holes

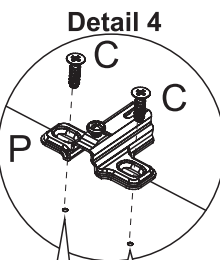

Please note:  
Pre-marked  
Holes

# STEP 3

## PARTS REQUIRED

2 - DIVISION PANEL x1

## HARDWARE REQUIRED

A  04  
Ø6,0 x 8mm

Q  02  
Right

## TOOLS REQUIRED

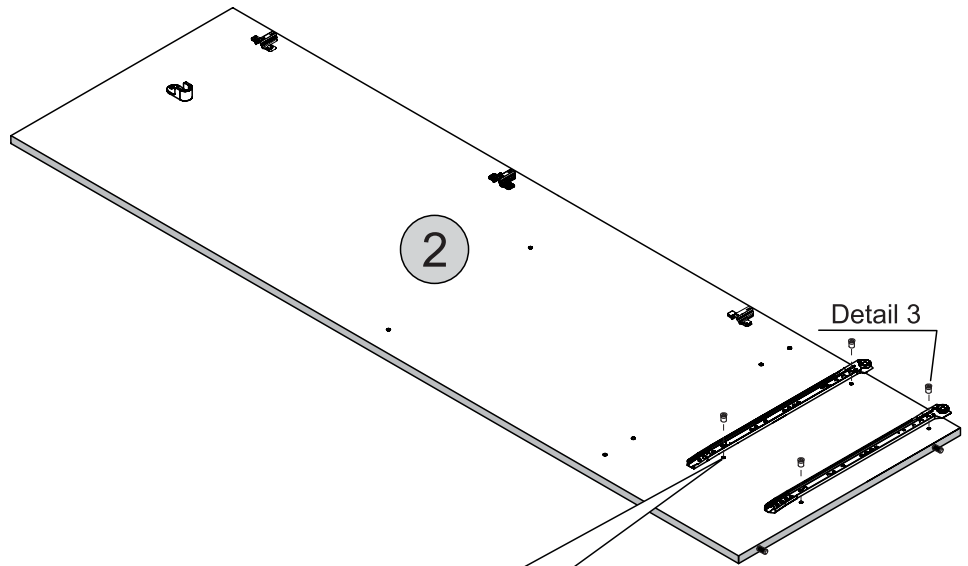

PLEASE NOTE  
PRE-DRILLED  
HOLES.

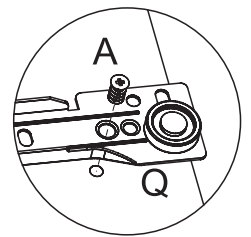
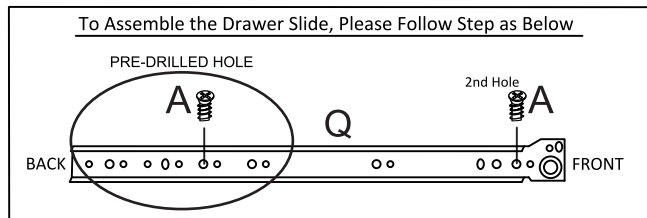

Detail 3

# STEP 4

## PARTS REQUIRED

4 - LEFT SIDE PANEL x1

## HARDWARE REQUIRED

C  08  
Ø4,0 x 14mm

M  01

P  03

## TOOLS REQUIRED

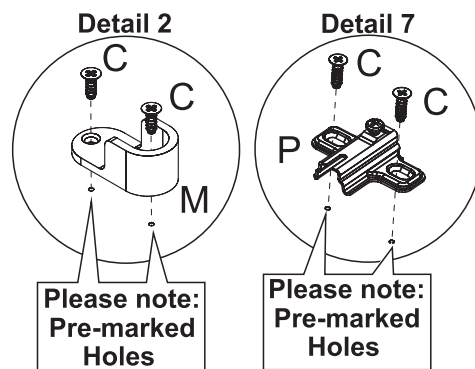
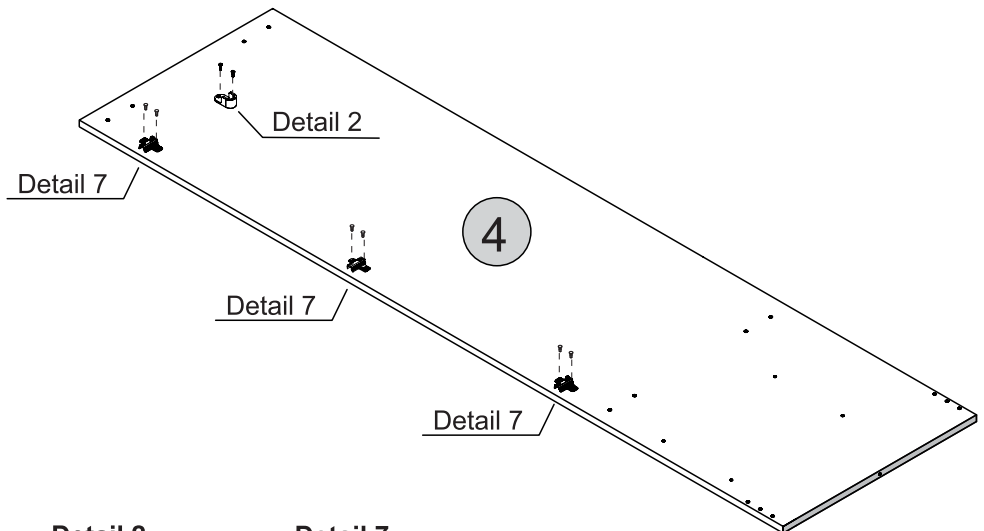
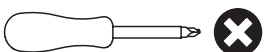





# STEP 5

## PARTS REQUIRED

4 - LEFT SIDE PANEL x1

## HARDWARE REQUIRED

- A  04  
Ø6,0 x 8mm
- H  02
- L  02
- Q  02

## TOOLS REQUIRED

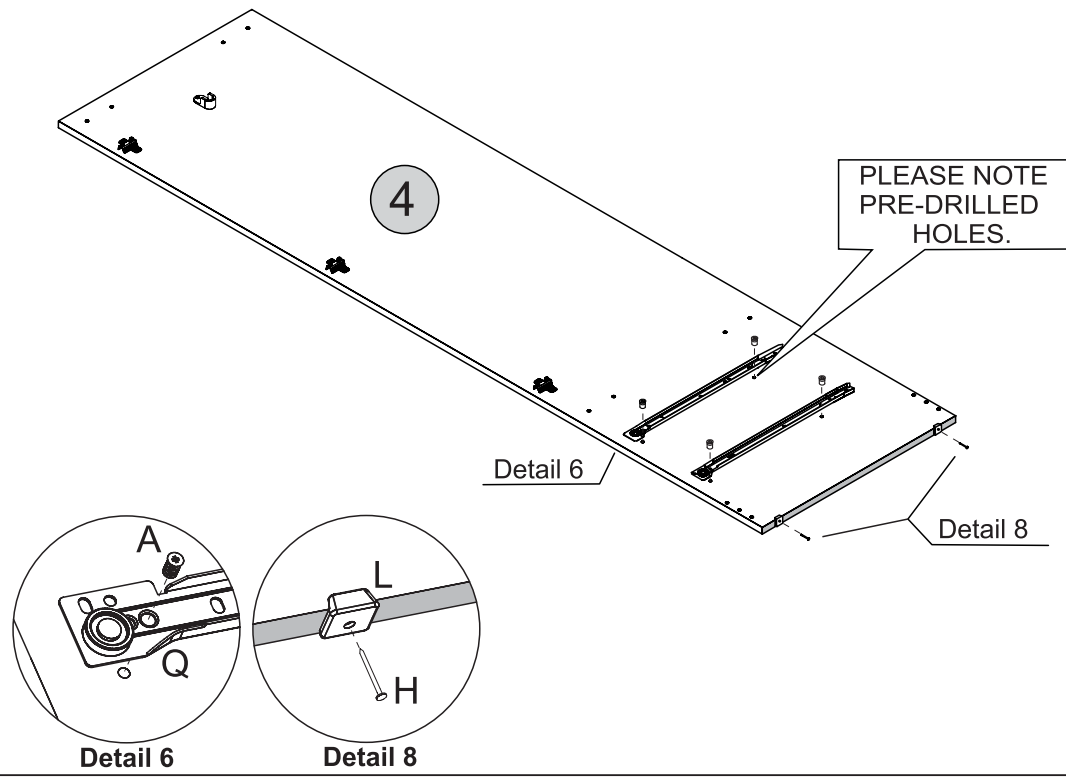
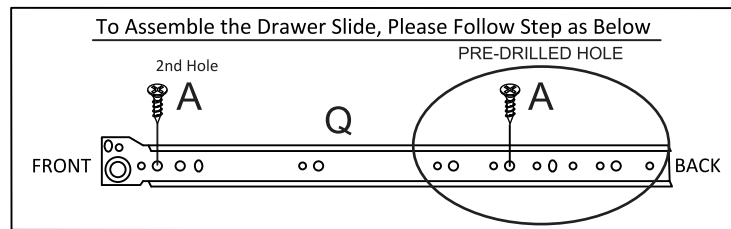
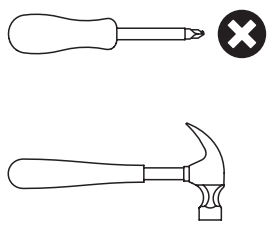



# STEP 6

## PARTS REQUIRED

6 - RIGHT SIDE PANEL x1

## HARDWARE REQUIRED

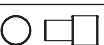
- C  06  
Ø4,0 x 14mm
- P  03
- Z  04

## TOOLS REQUIRED

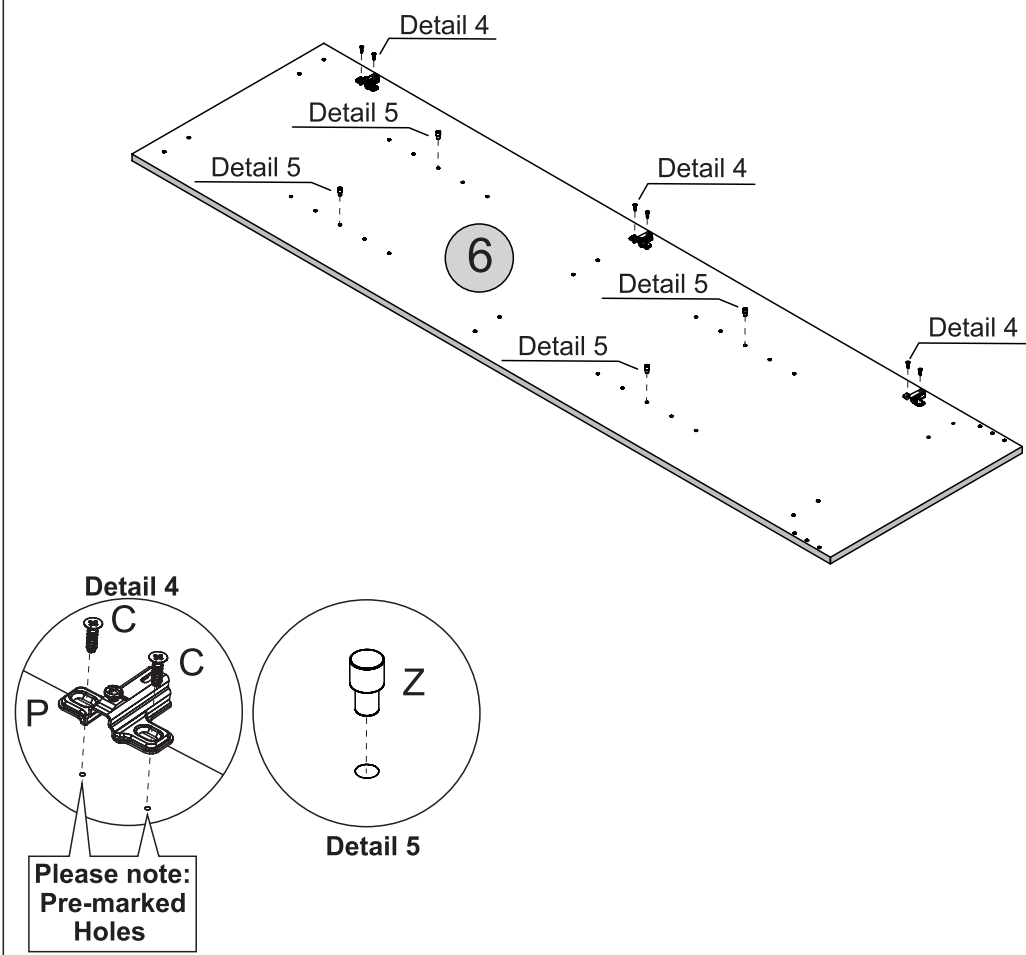
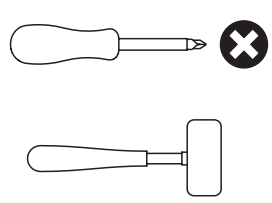





# STEP 7

## PARTS REQUIRED

- 6 - RIGHT SIDE PANEL x1
- 7 - FRONT BASEBOARD x1
- 8 - BACK BASEBOARD x1

## HARDWARE REQUIRED

- G  08  
Ø6,0 x 30mm
- H  04  
10 x 10
- L  04
- V  01

## TOOLS REQUIRED

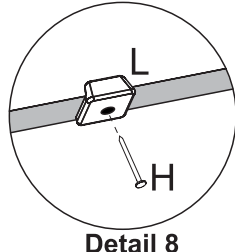
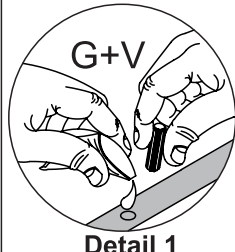
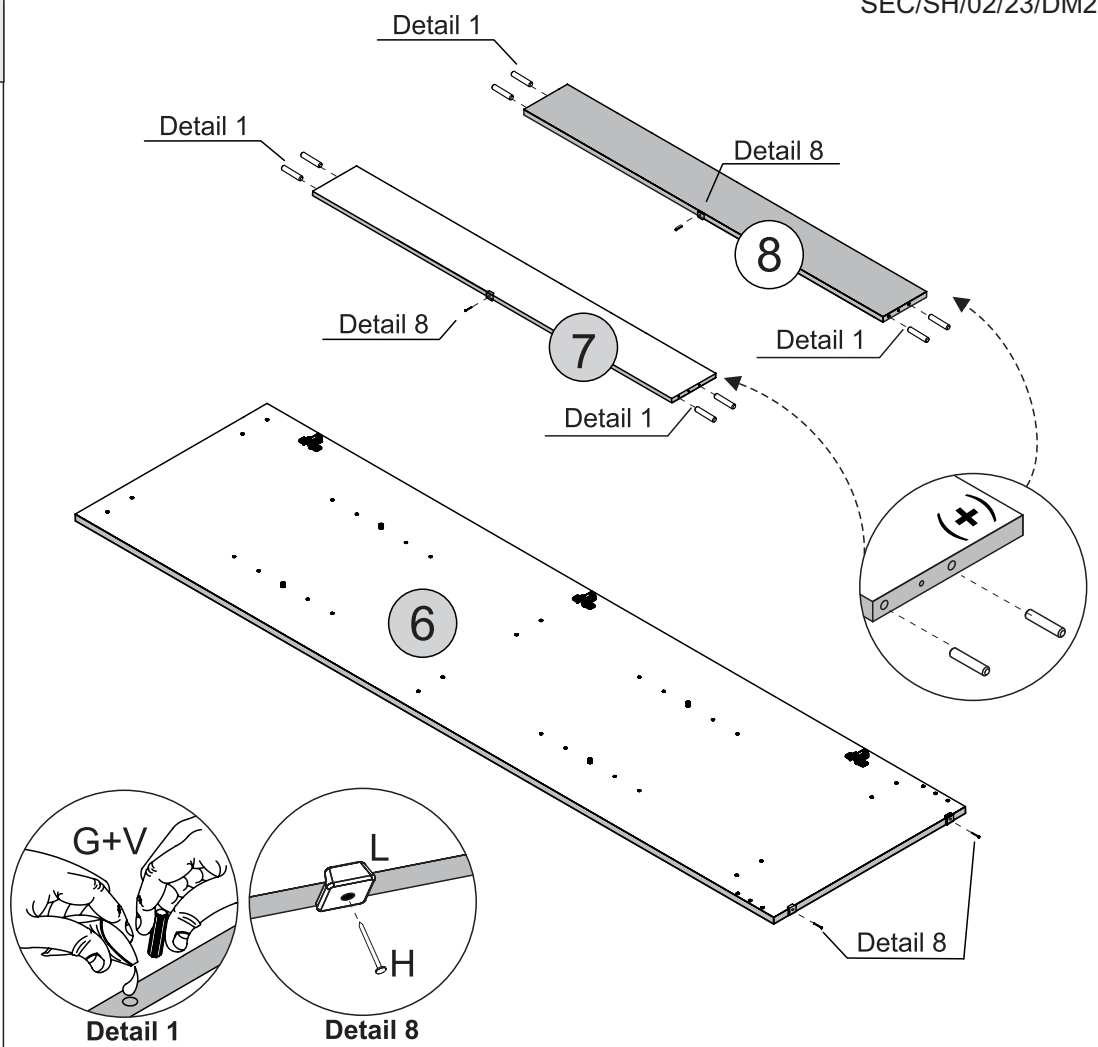
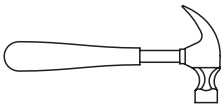



# STEP 8

## PARTS REQUIRED

- 1 - LARGE BASE PANEL x1
- 3 - TOP PANEL x1
- 5 - SMALL BASE PANEL x1
- 20 - SHELF x1

## HARDWARE REQUIRED

- G  14  
Ø6,0 x 30mm
- V  01

## TOOLS REQUIRED

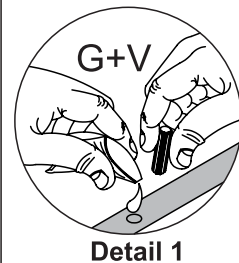
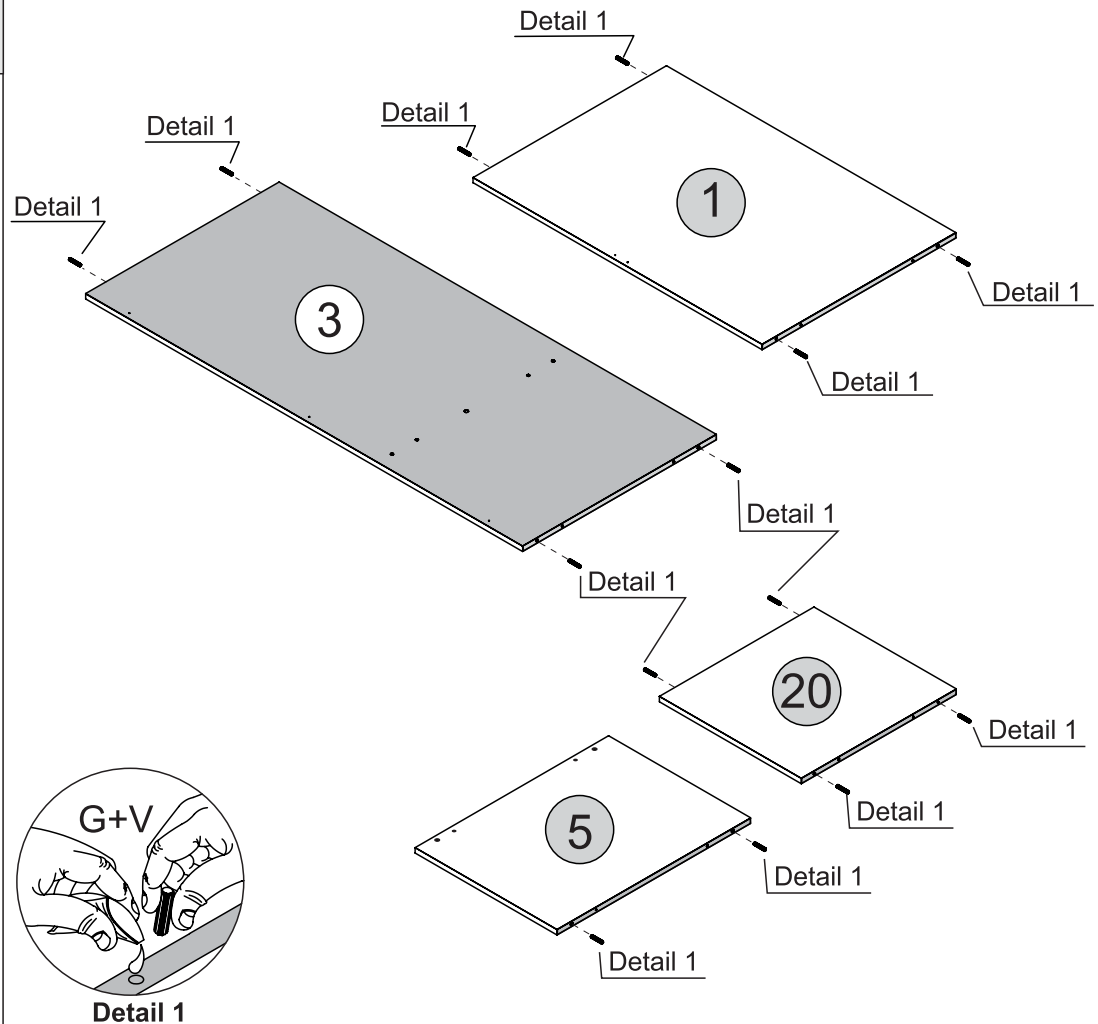
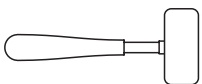

# STEP 9

## PARTS REQUIRED

1 - LARGE BASE PANEL x1

3 - TOP PANEL x1

## HARDWARE REQUIRED

B  04  
Ø3,5 x 12mm

F  03  
Ø4,0 x 12mm

A1  02

J  03

## TOOLS REQUIRED

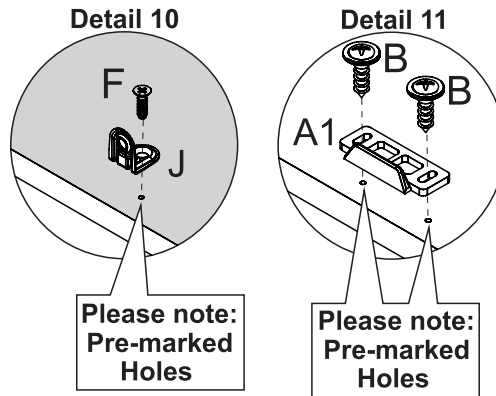
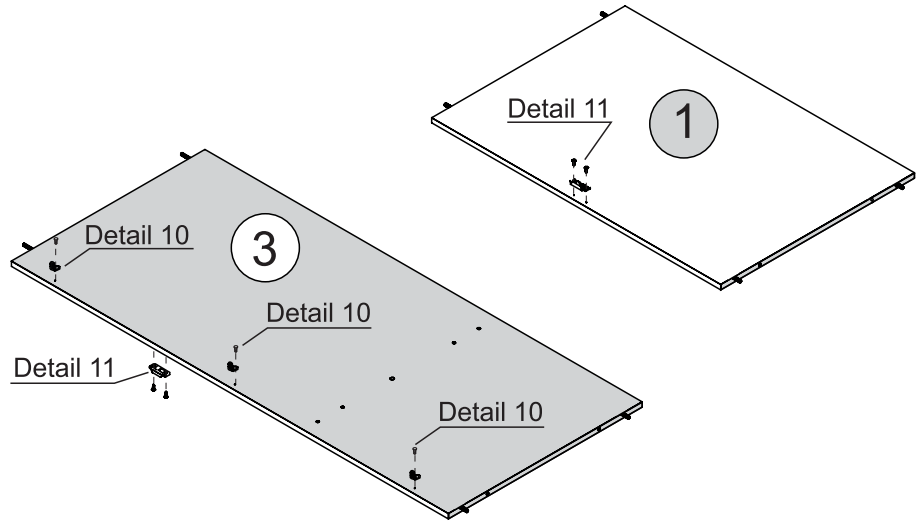
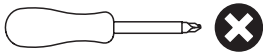

# STEP 10

## PARTS REQUIRED

1 - LARGE BASE PANEL x1

2 - DIVISION PANEL x1

3 - TOP PANEL x1

5 - SMALL BASE PANEL x1

## HARDWARE REQUIRED

E  06  
Ø4,0 x 45mm

V  01

## TOOLS REQUIRED

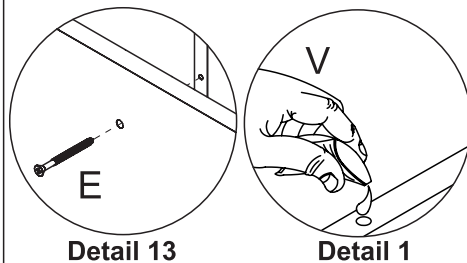
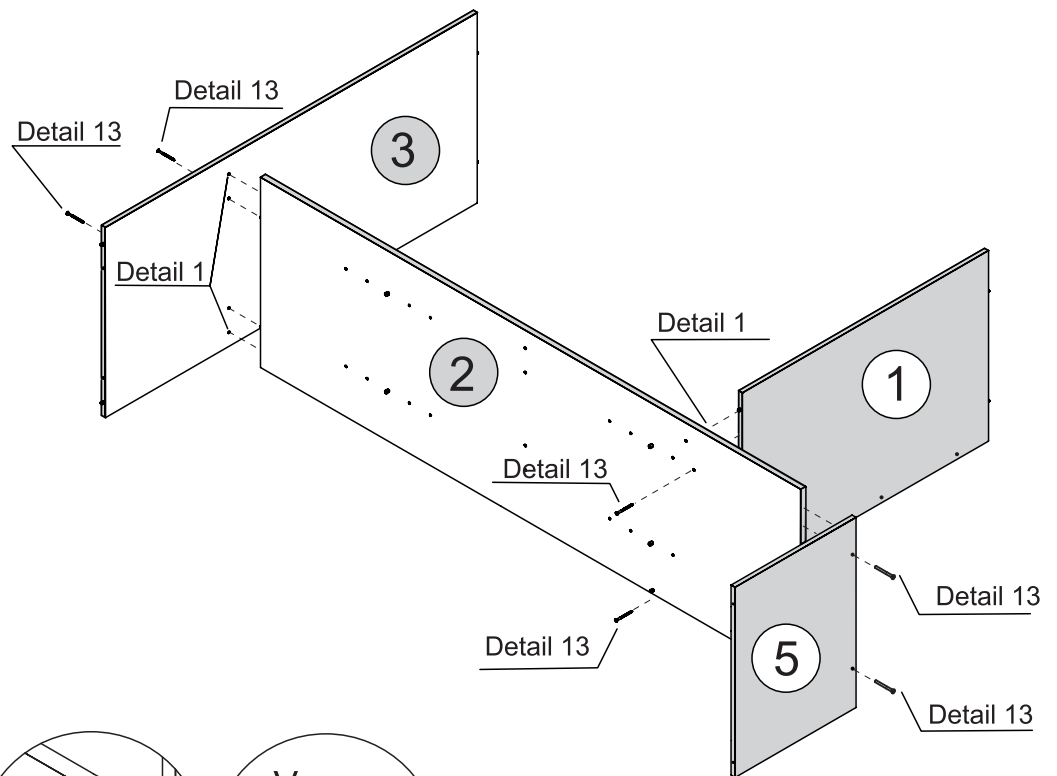
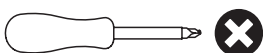





# STEP 11

**PARTS REQUIRED**

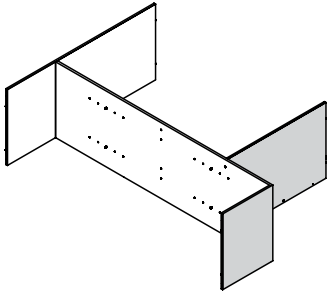
4 - LEFT SIDE PANEL x1



**HARDWARE REQUIRED**

- E  Ø4,0 x 45mm 04
- V  01

**TOOLS REQUIRED**

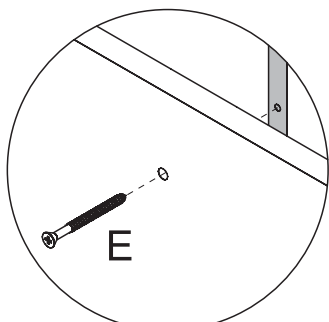
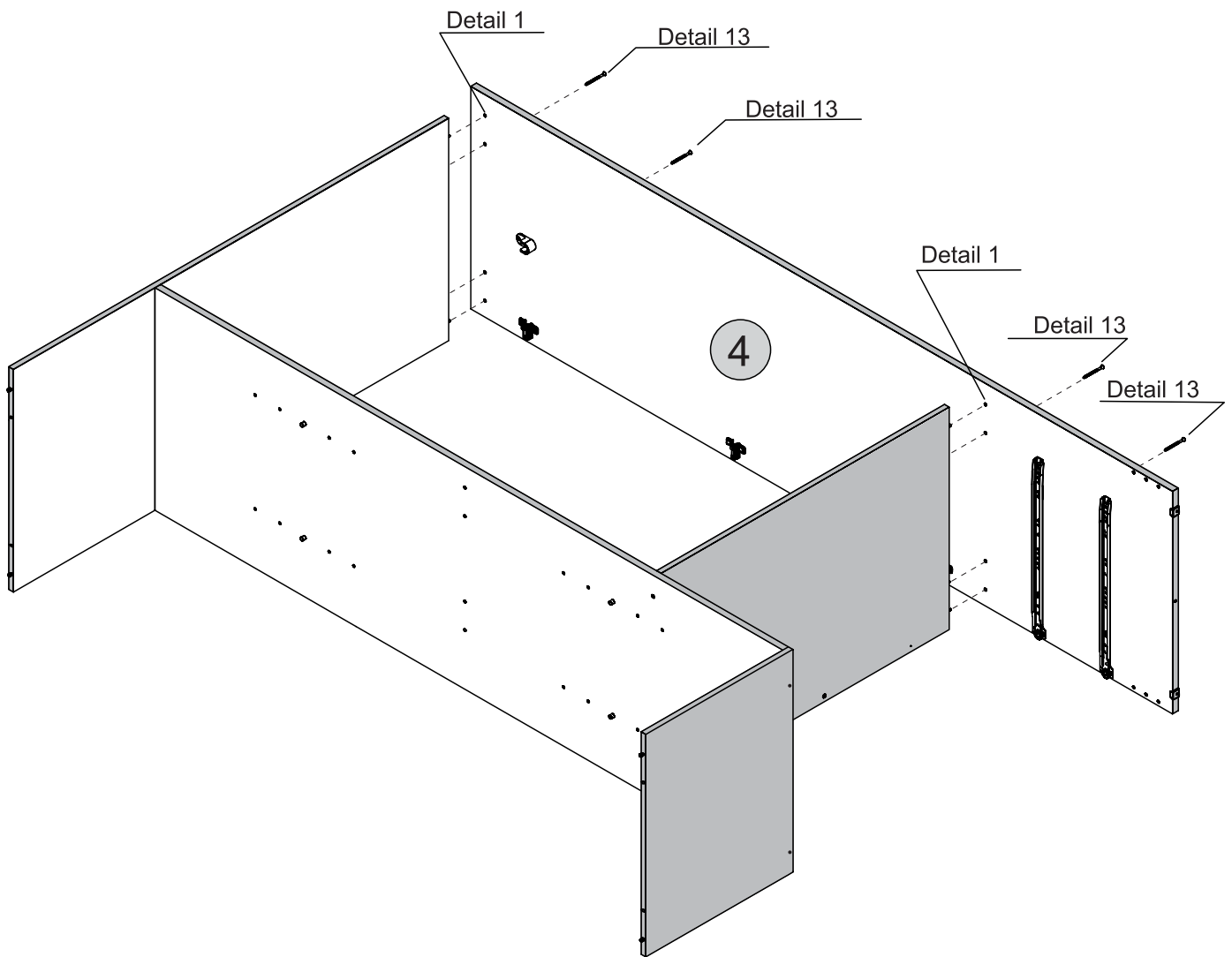
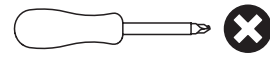

Detail 13

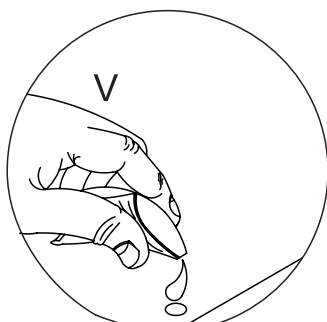

Detail 1



# STEP 12

## PARTS REQUIRED

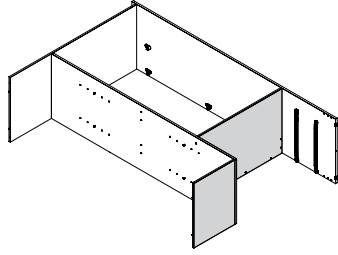
6 - RIGHT SIDE PANEL	x1
7 - FRONT BASEBOARD	x1
8 - BACK BASEBOARD	x1
20 - SHELF	x1



## HARDWARE REQUIRED

E	 Ø4,0 x 45 mm	14
V	 Glue	01

## TOOLS REQUIRED

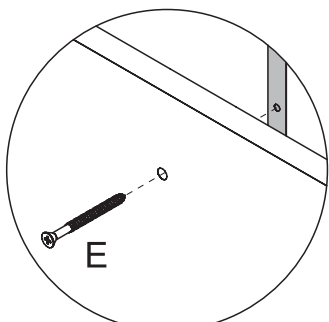
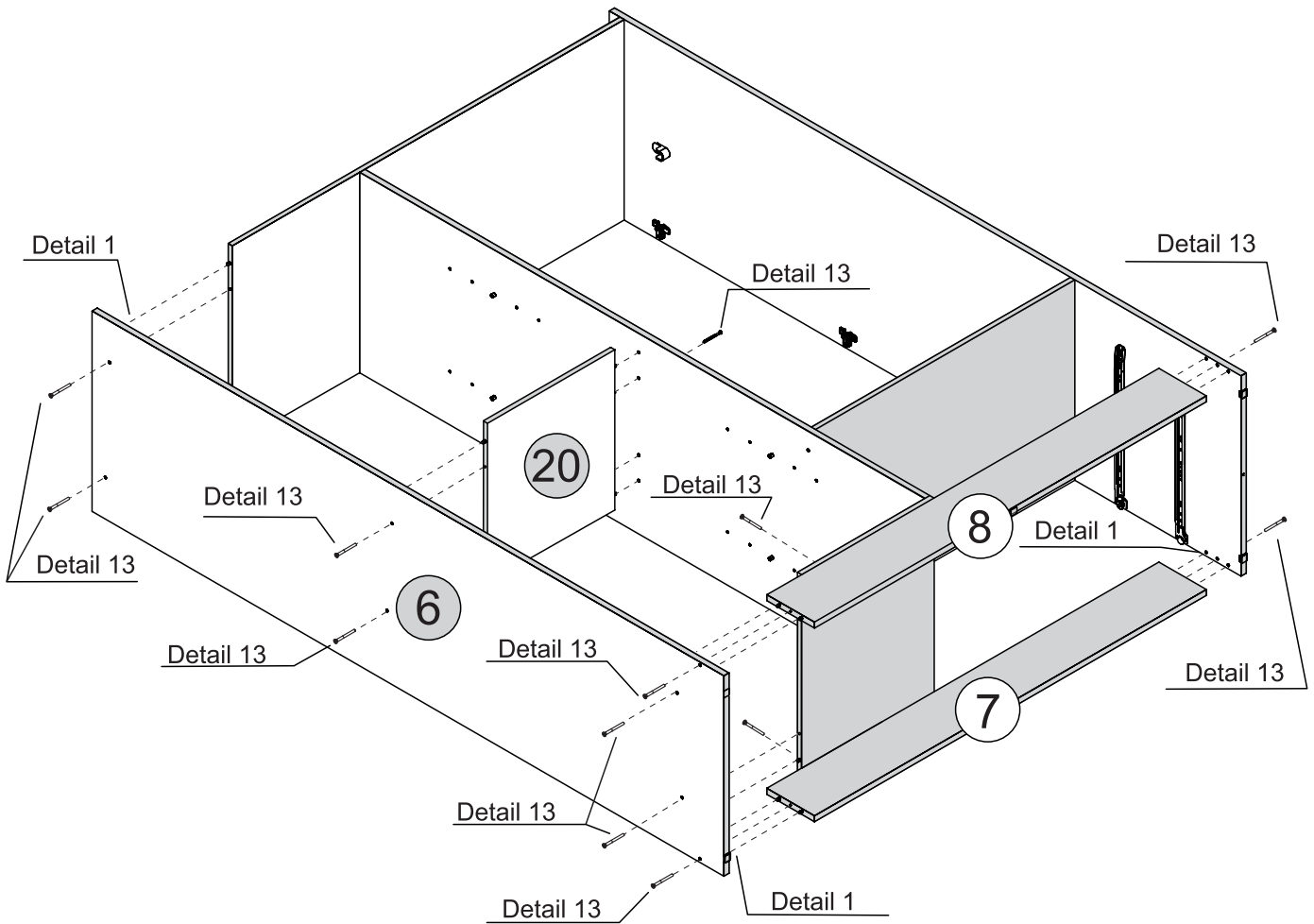
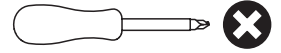

Detail 13

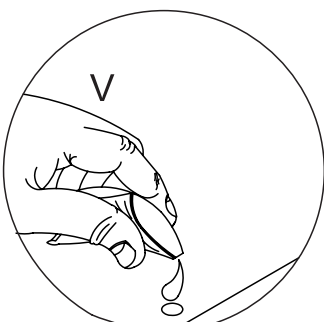

Detail 1



# STEP 13

**PARTS REQUIRED**

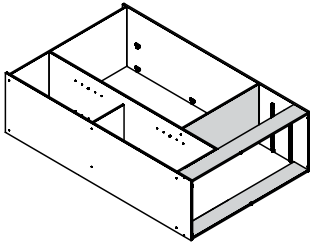
- 9 - SMALL BACK PANEL x2
- 21 - LARGE BACK PANEL x1

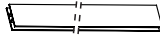

**HARDWARE REQUIRED**

- H  62
- I  14
- R  01

**TOOLS REQUIRED**

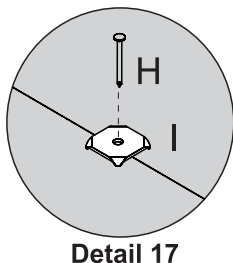
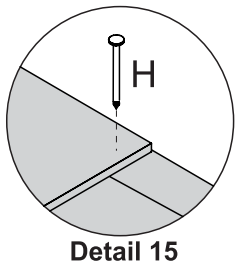
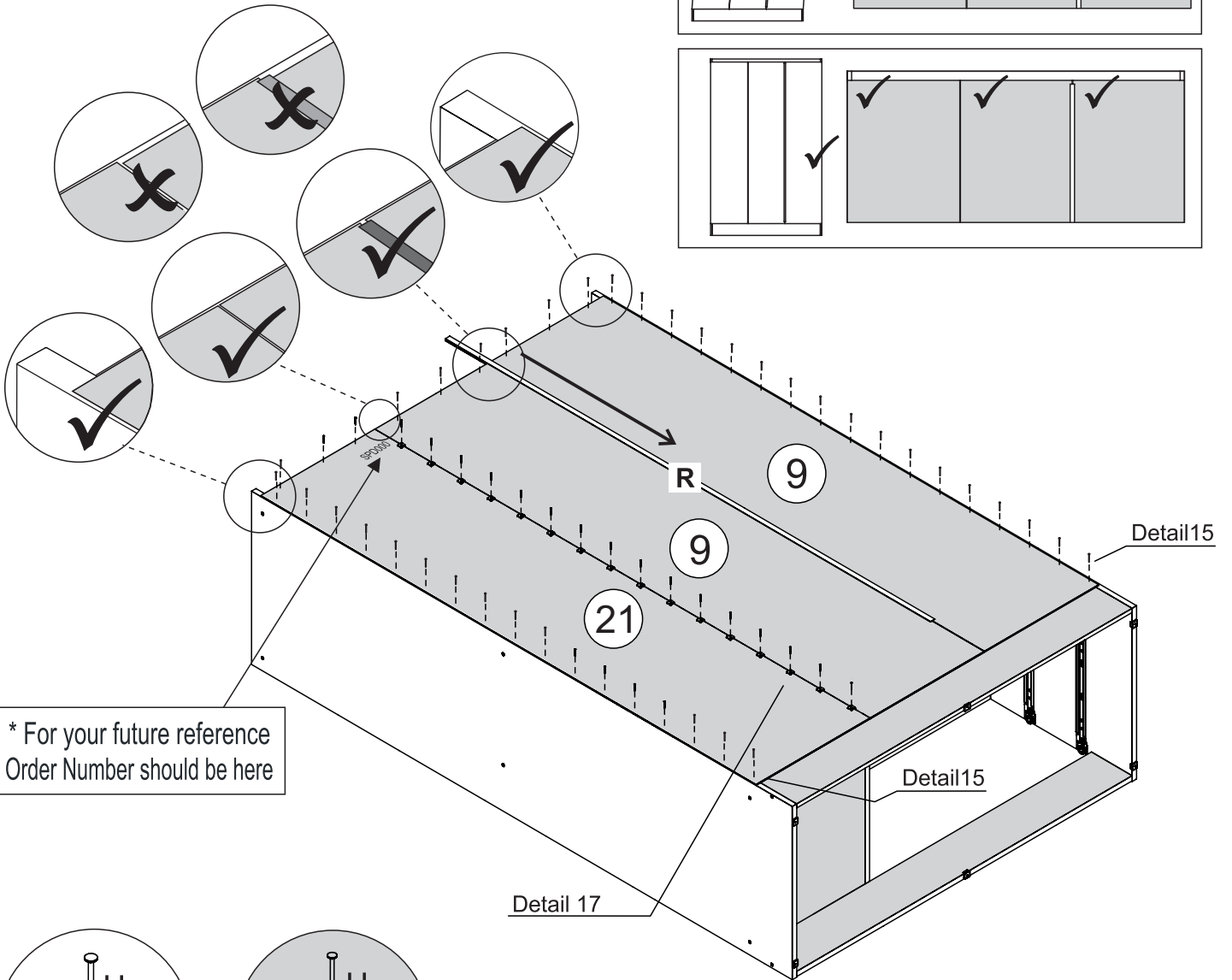
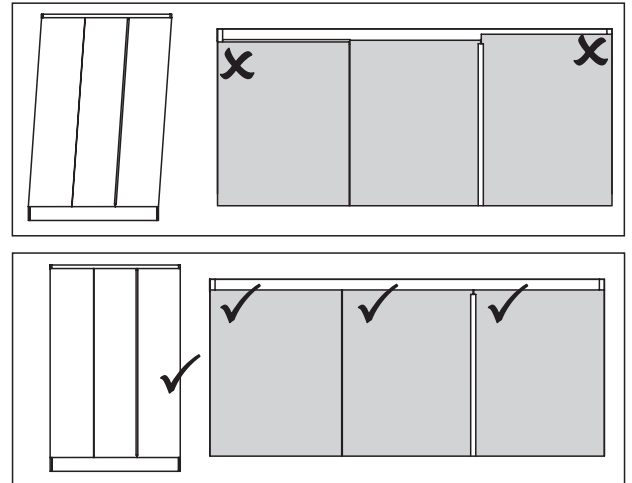
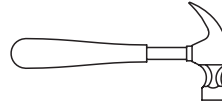

# STEP 14

**PARTS REQUIRED**

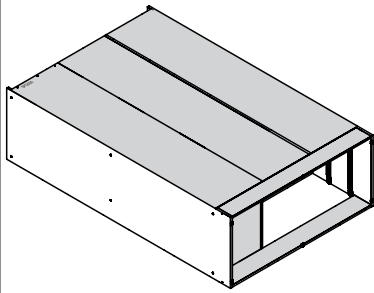

**HARDWARE REQUIRED**

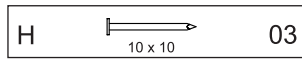

**TOOLS REQUIRED**

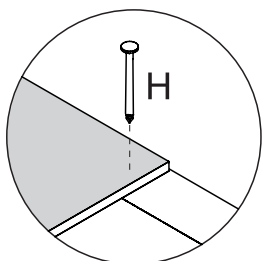
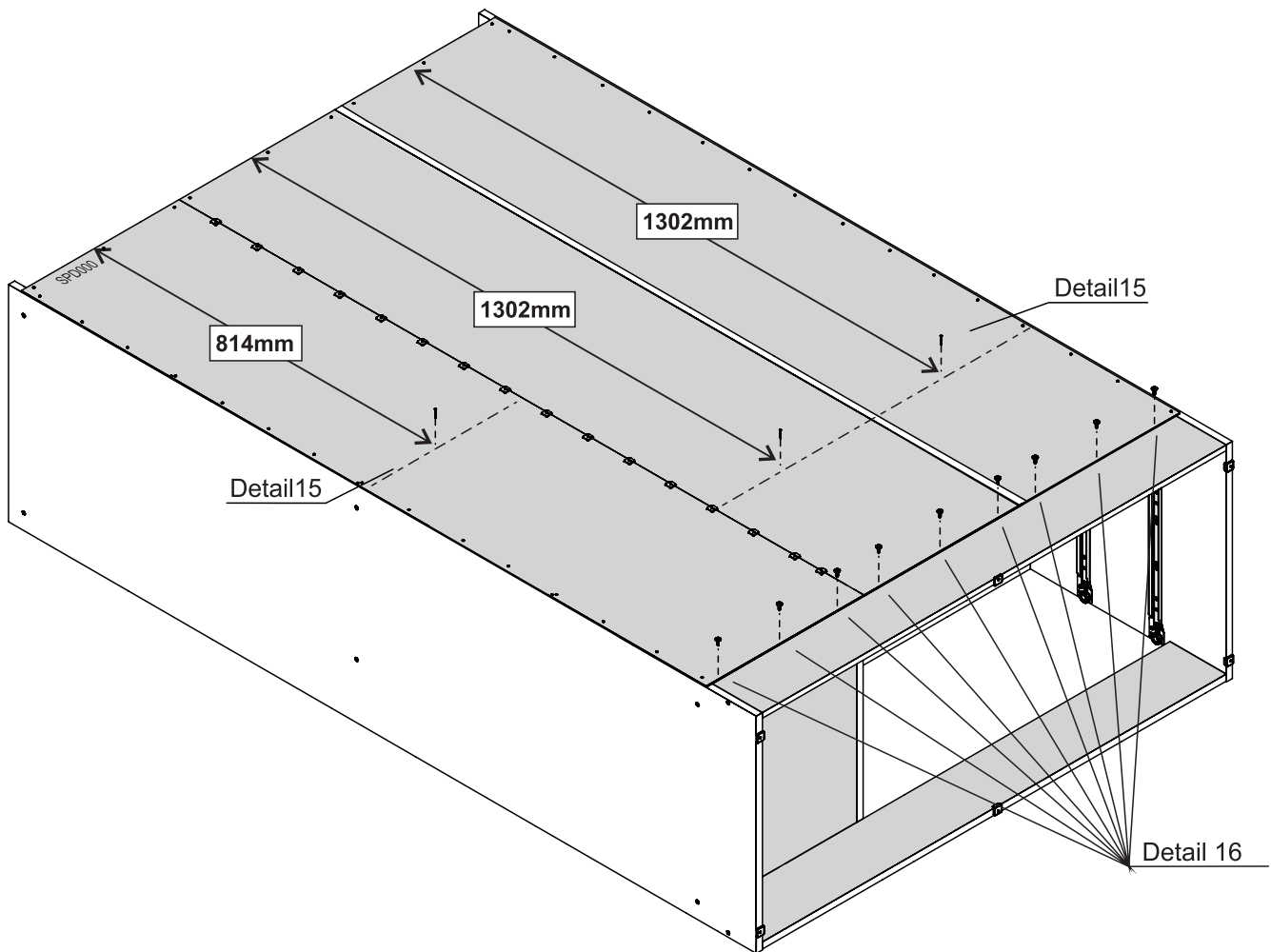
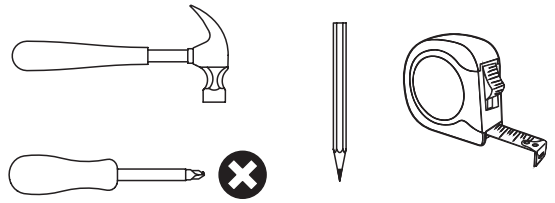

Detail 15

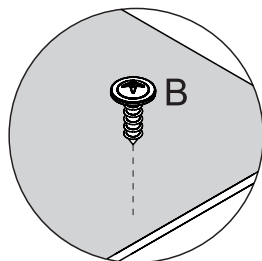

Detail 16

# STEP 15

## PARTS REQUIRED

10 - FRAME x1

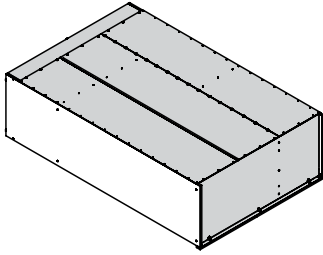

## HARDWARE REQUIRED

J 02

F Ø4,0 x 12mm 07

## TOOLS REQUIRED

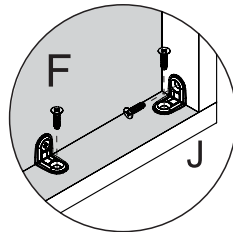
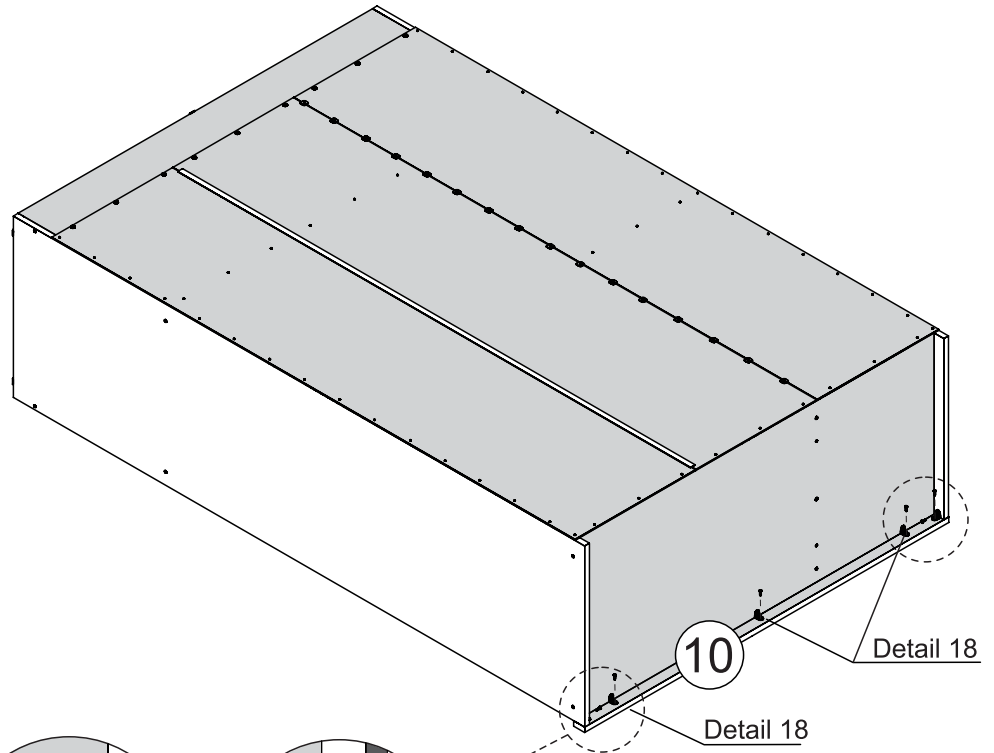
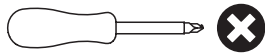

Detail 18

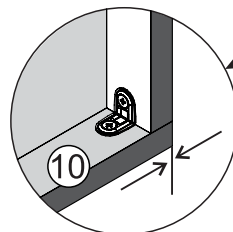

Align corners

# STEP 16

## PARTS REQUIRED

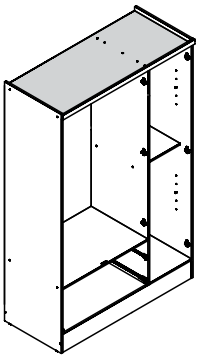

## HARDWARE REQUIRED

N 01

## TOOLS REQUIRED

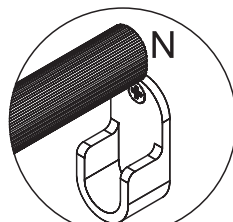
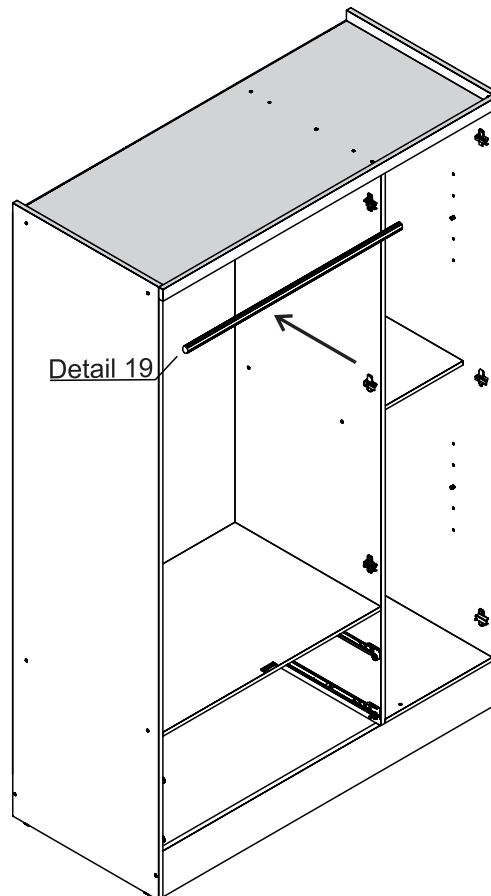



Detail 19

# STEP 17

## PARTS REQUIRED

- 15 - DRAWER SIDE x4
- 16 - DRAWER BACK PANEL x2
- 17 - DRAWER FRONT x2
- 19 - DRAWER BOTTOM SUPPORT BAR x2

## HARDWARE REQUIRED

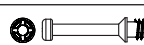
- G  20  
Ø6,0 x 30mm
- V  01
- X  04

## TOOLS REQUIRED

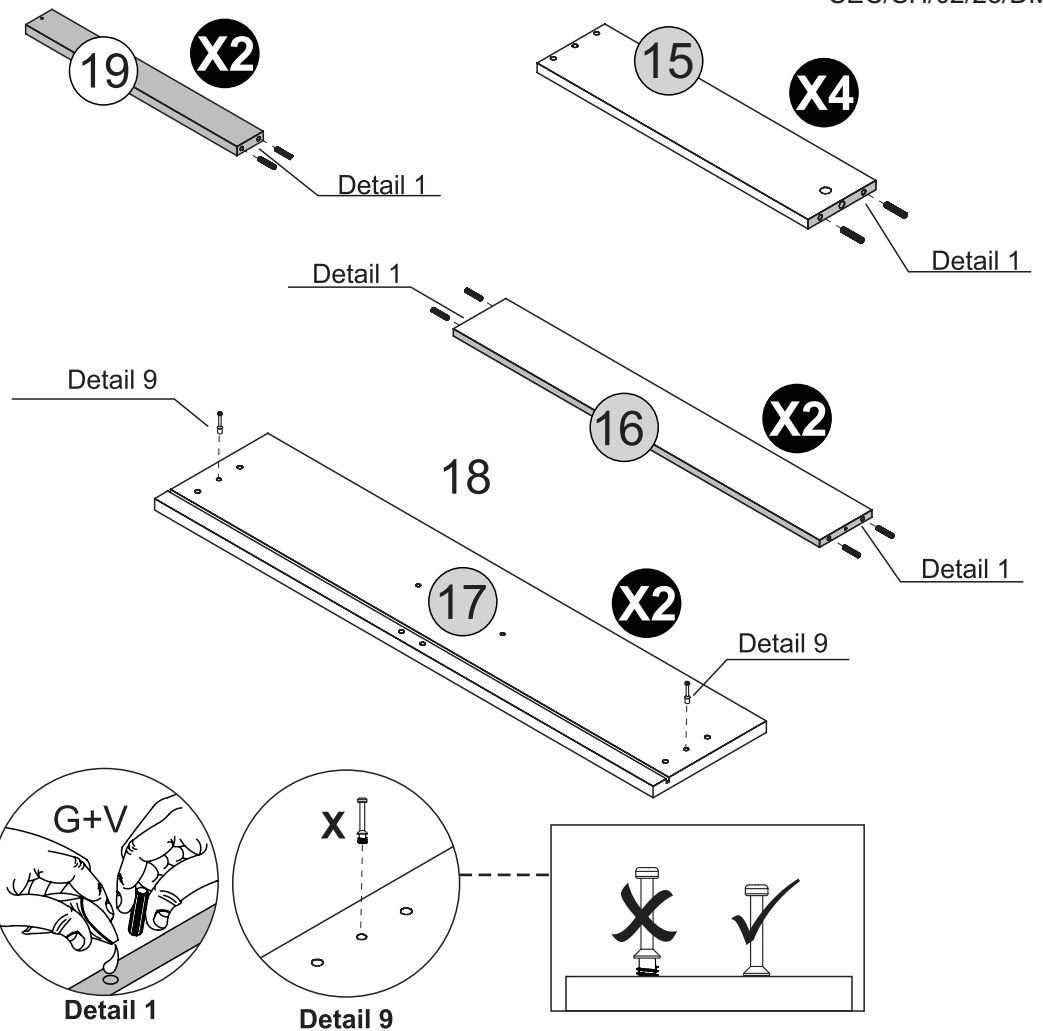
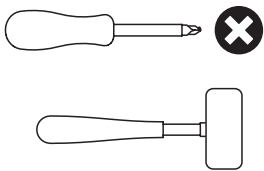

# STEP 18

## PARTS REQUIRED

- 15 - DRAWER SIDE x4
- 16 - DRAWER BACK PANEL x2

## HARDWARE REQUIRED

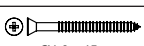
- E  04  
Ø4,0 x 45mm

## TOOLS REQUIRED

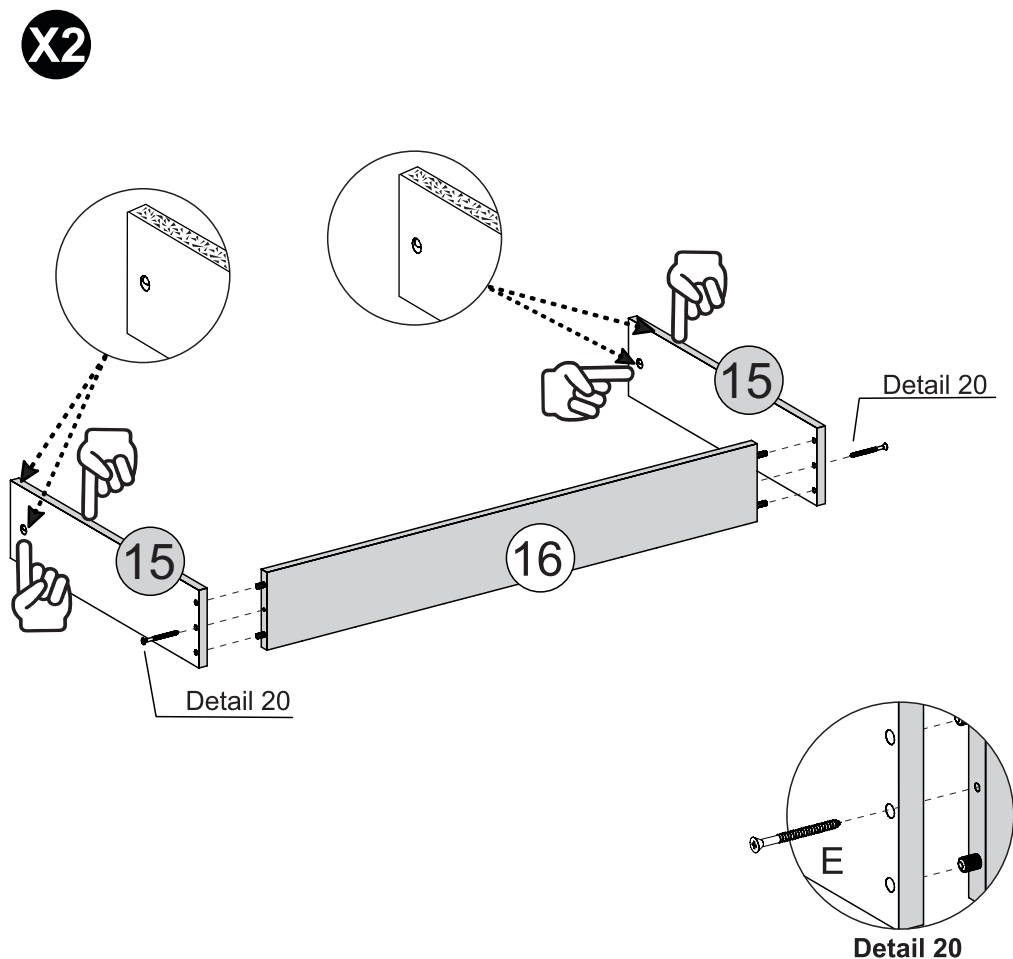
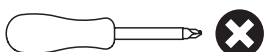

# STEP 19

**PARTS REQUIRED**

17 - DRAWER FRONT x2

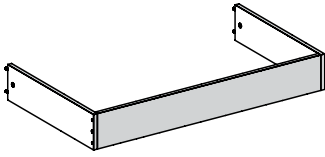

**HARDWARE REQUIRED**

V  01

**TOOLS REQUIRED**

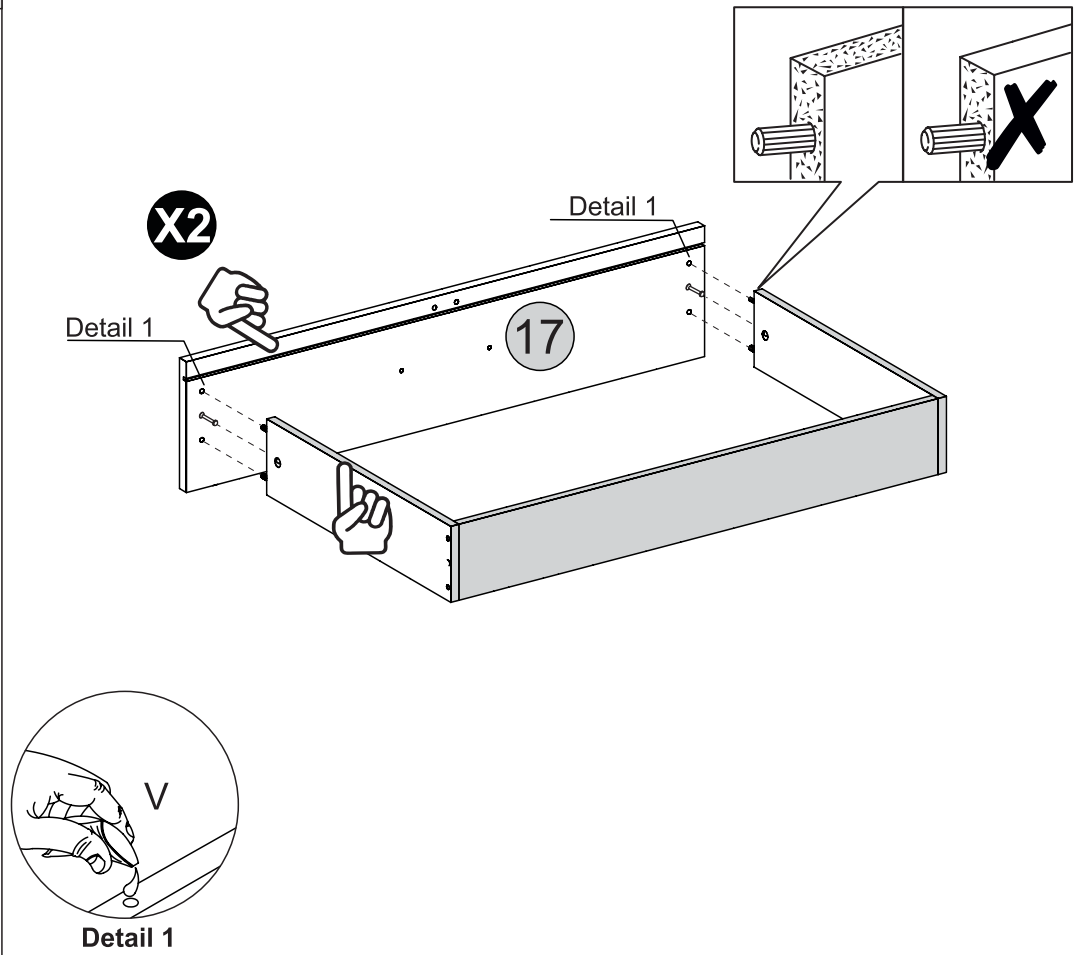

# STEP 20

**PARTS REQUIRED**

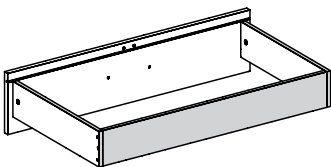

**HARDWARE REQUIRED**

U  08

W  04

**TOOLS REQUIRED**

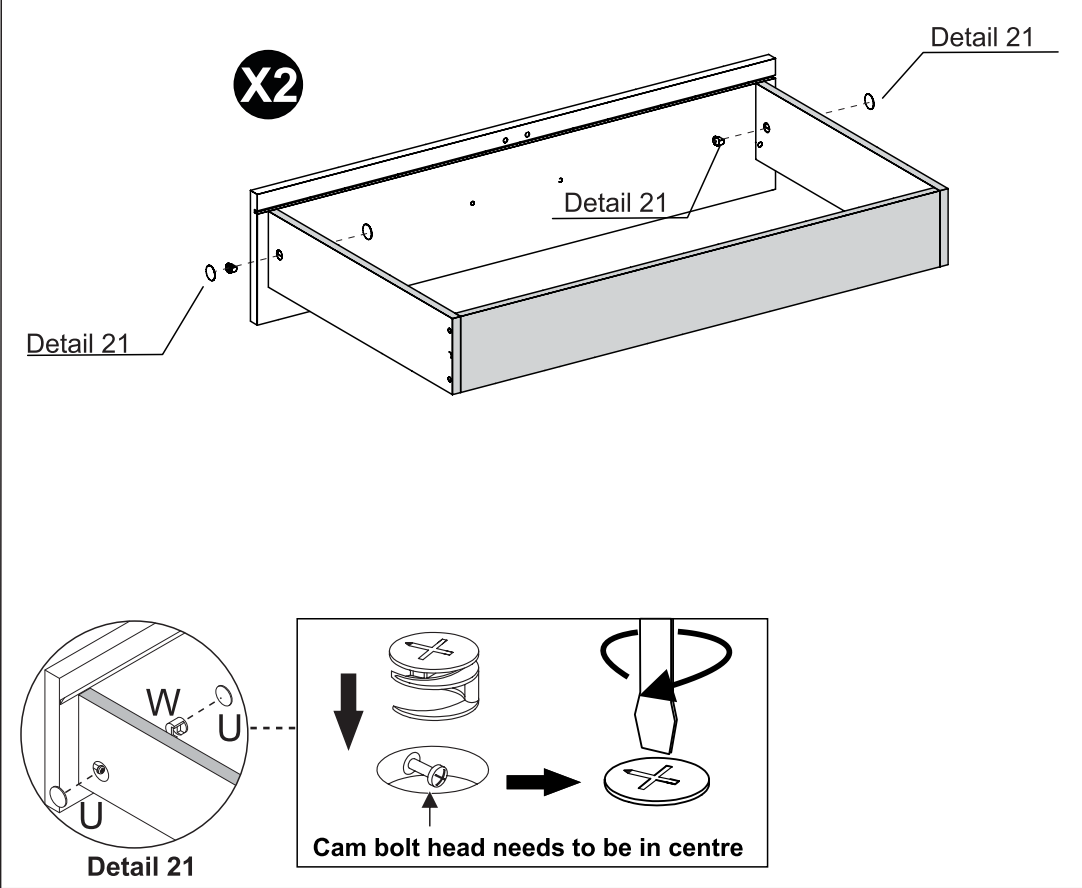
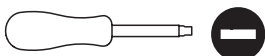

# STEP 21

## PARTS REQUIRED

18 - DRAWER BOTTOM x2

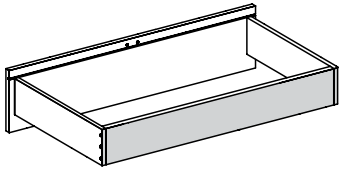

## HARDWARE REQUIRED

H  08  
10 x 10

## TOOLS REQUIRED

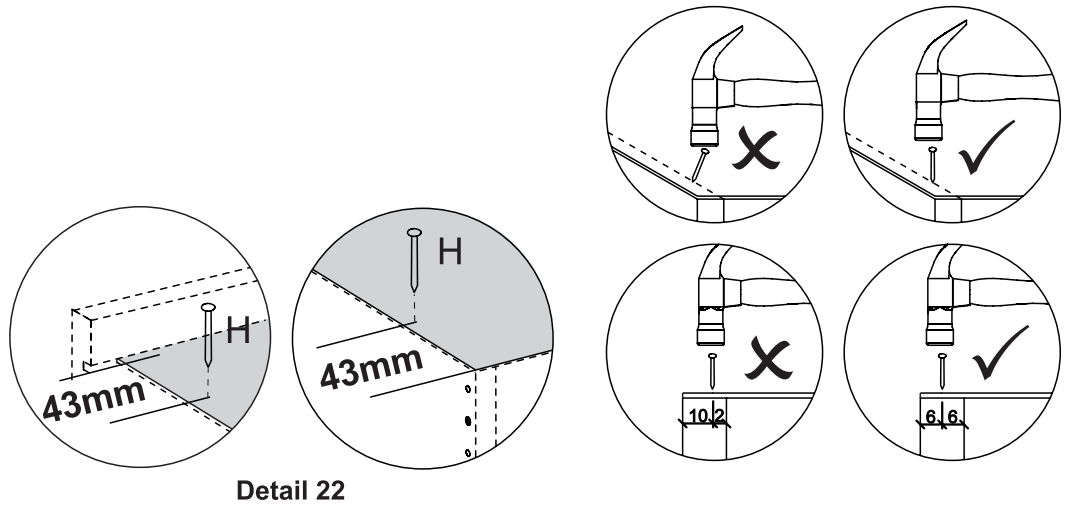
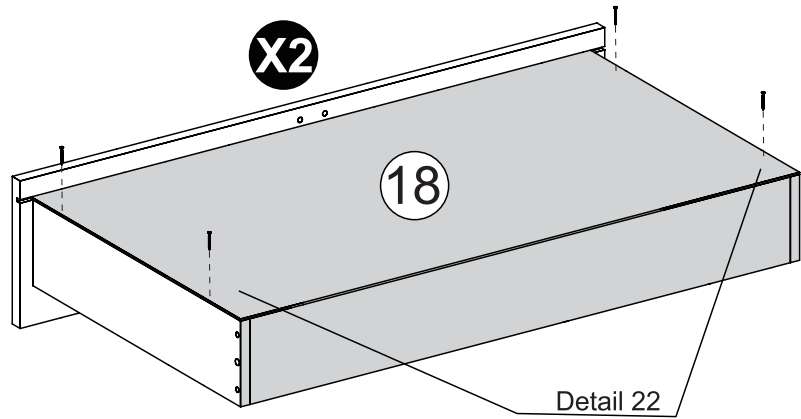
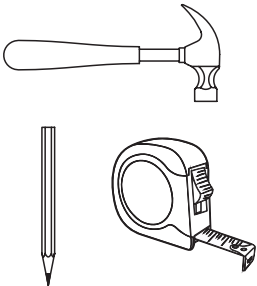

Detail 22

# STEP 22

## PARTS REQUIRED

19 - DRAWER BOTTOM SUPPORT BAR x2

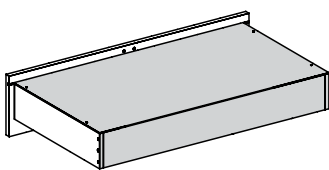

## HARDWARE REQUIRED

H  12  
10 x 10

V  01  
Glue

## TOOLS REQUIRED

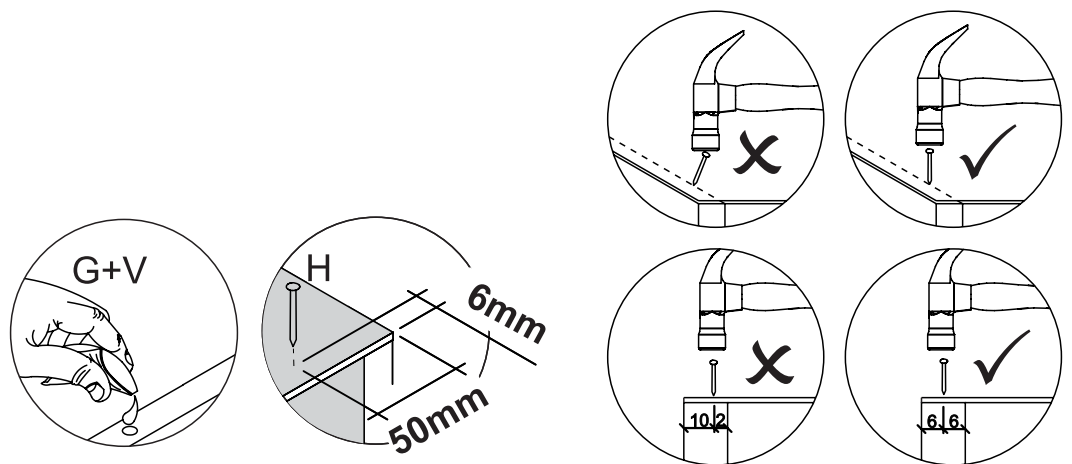
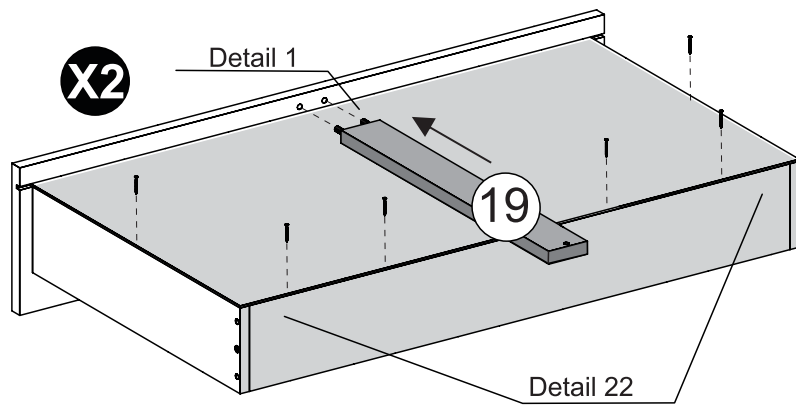
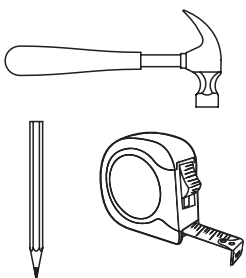

Detail 1

Detail 22



# STEP 23

## PARTS REQUIRED

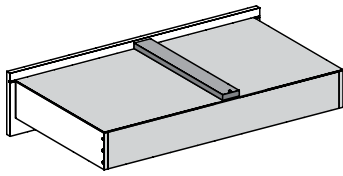

## HARDWARE REQUIRED

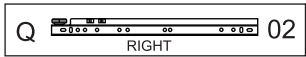
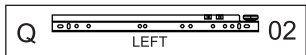
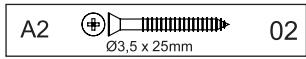
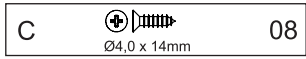

## TOOLS REQUIRED

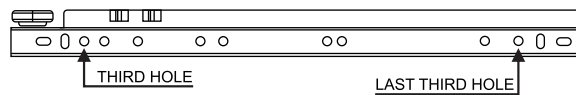
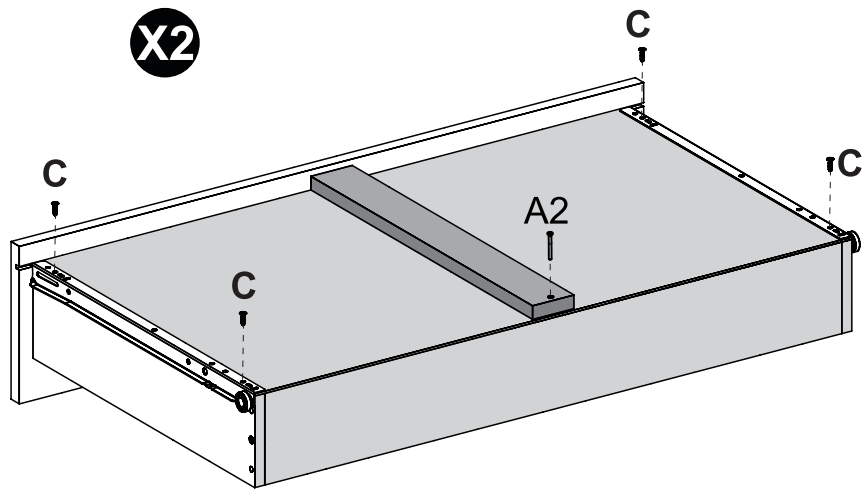
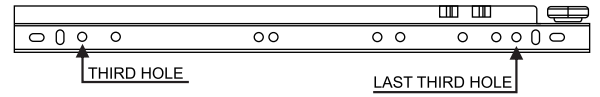

# STEP 24

## PARTS REQUIRED



## HARDWARE REQUIRED

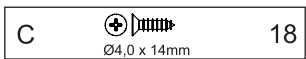

## TOOLS REQUIRED

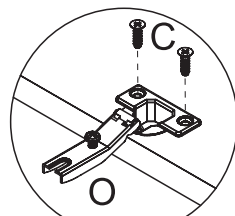
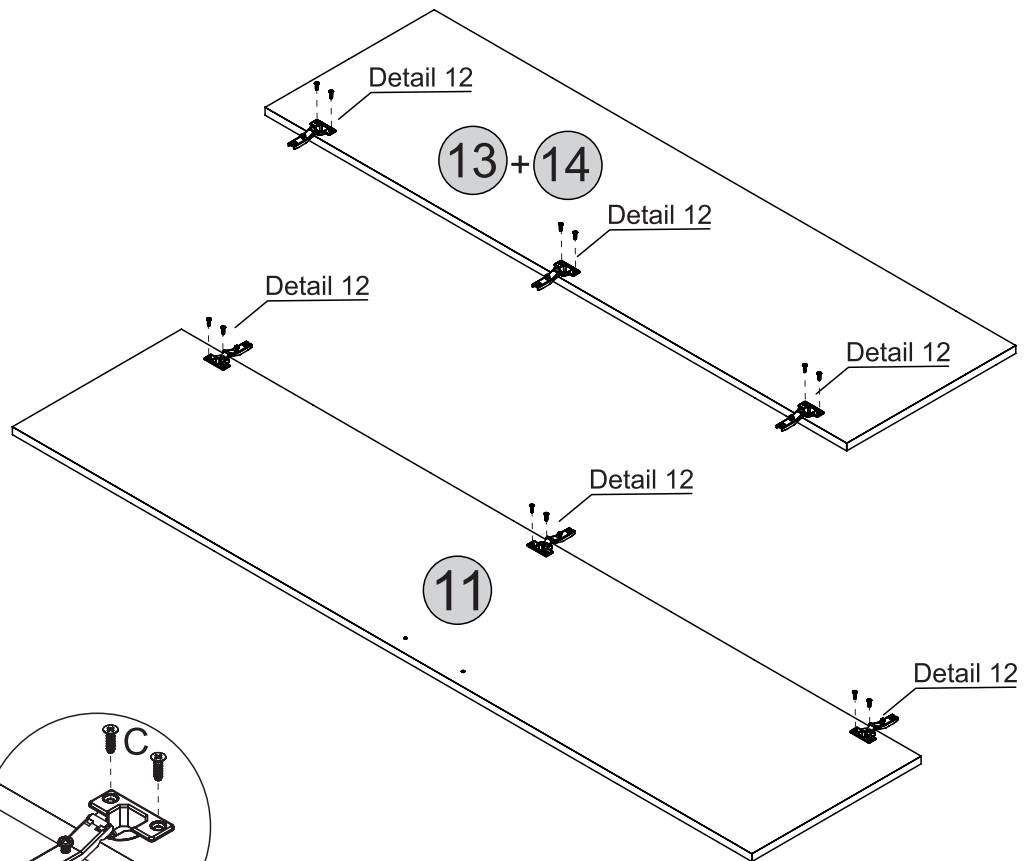
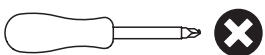

Detail 12

# STEP 25

## PARTS REQUIRED

11 - LARGE DOOR x1

13 - RIGHT SMALL DOOR x1

14 - LEFT SMALL DOOR x1

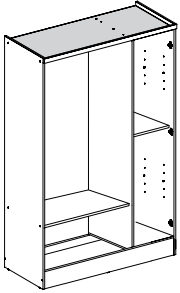

## HARDWARE REQUIRED

U  12

## TOOLS REQUIRED

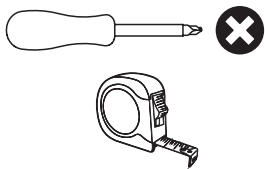

**!**  
Please note the top or bottom edges of the doors are labelled LEFT or RIGHT to make them easier to identify when assembling.

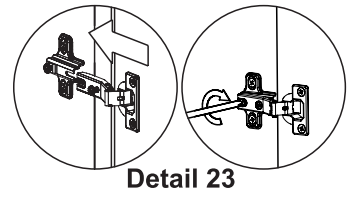
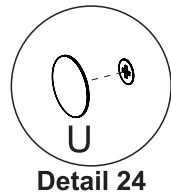
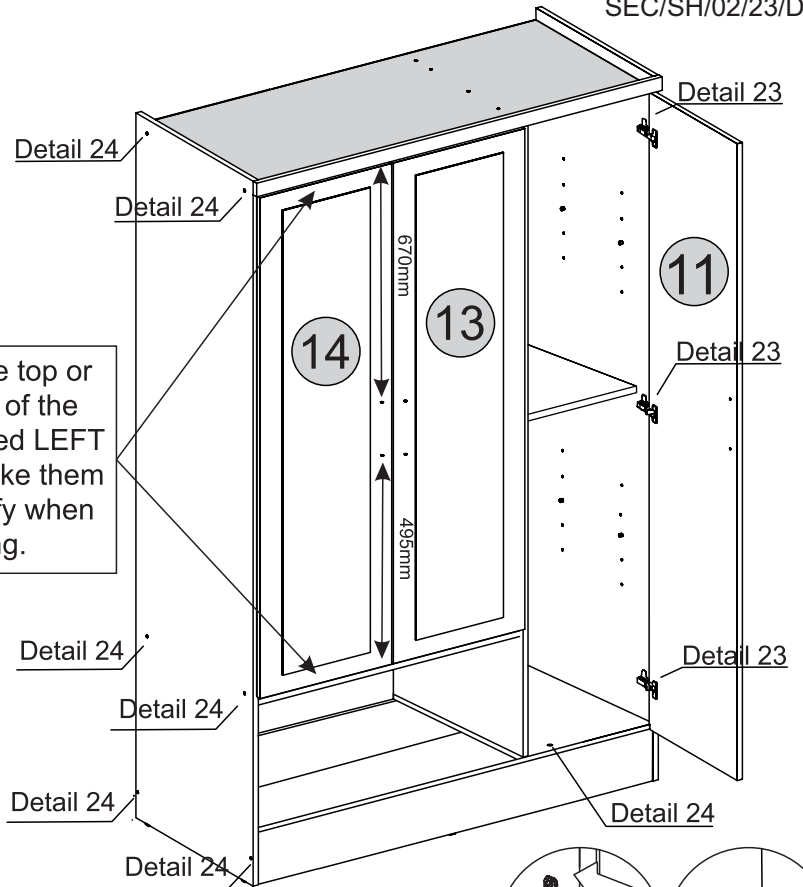

# STEP 26

## PARTS REQUIRED

12 - MOVEABLE SHELF x2

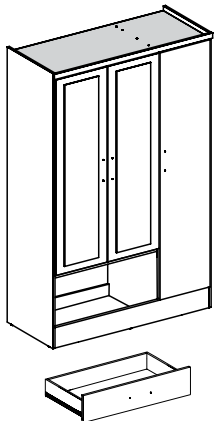

## HARDWARE REQUIRED

D  10  
Ø4.0 x 20mm

T  05

## TOOLS REQUIRED

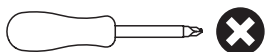

**TIP**  
If desired, after assembly use an alcohol cleaner to erase the number printed on the parts.

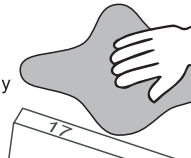

**!**  
See the last page

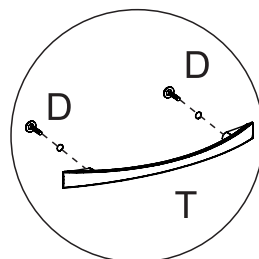
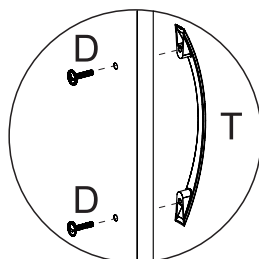
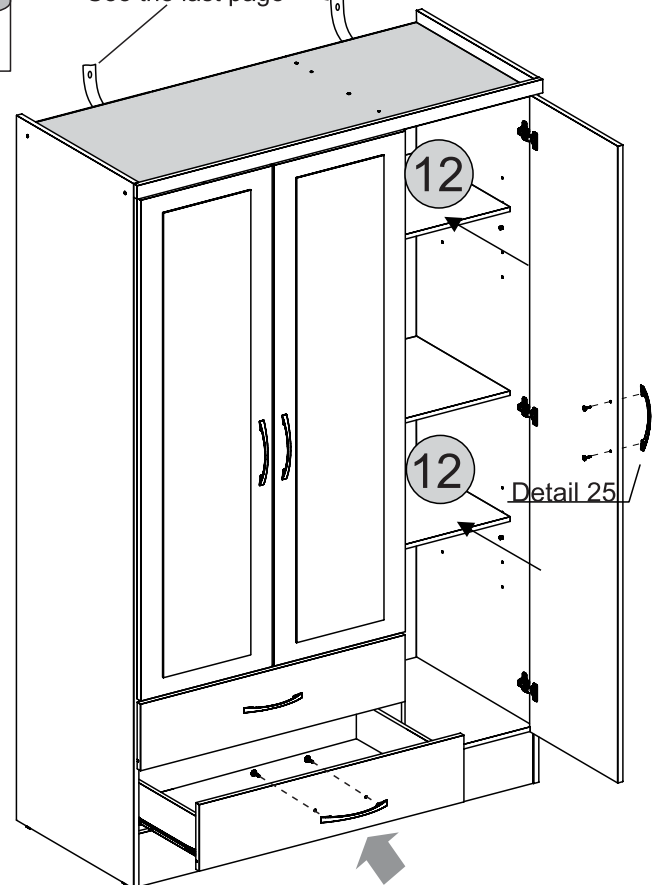

Detail 25

# STEP 25

## PARTS REQUIRED

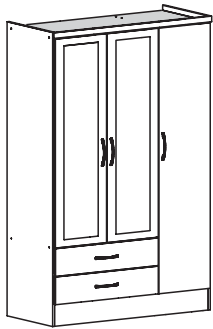

## HARDWARE REQUIRED

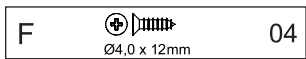

## TOOLS REQUIRED



Detail 26

Detail 26

Drawer Adjustment

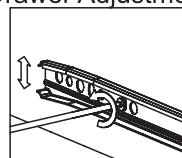

Drawer Lock

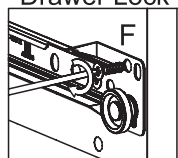

Detail 26

Height Adjustment

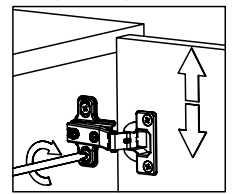

Internal Adjustment

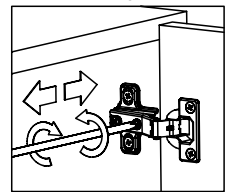

Depth Adjustment

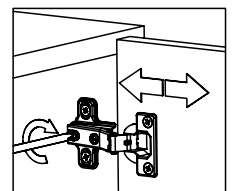
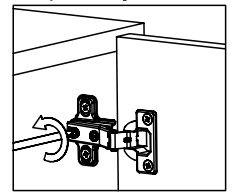

# WARNING

**Serious or fatal injuries can occur from furniture tipping over. To prevent the furniture from tipping over we recommend that it is permanently fixed to the wall.**

Wall fixings are not supplied with this product as different wall materials require different types of fixing devices.

Please make sure you use fixings suitable for the walls in your home.

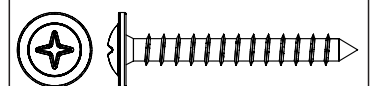
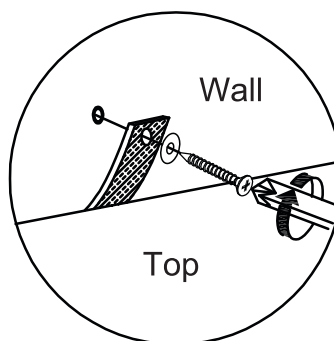
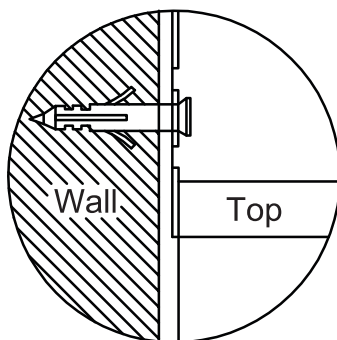
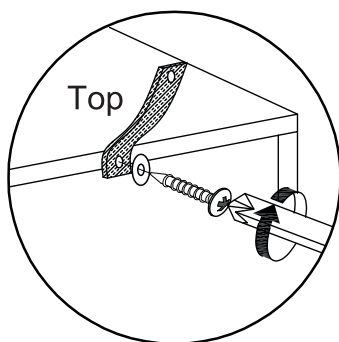

**Y** Flan Head Screw  
Ø3,5 x 30mm (2x)



**K** Washer (4x)



**S** Strap (2x)