

NEVADA 2 DOOR 1 DRAWER WARDROBE ASSEMBLY INSTRUCTIONS

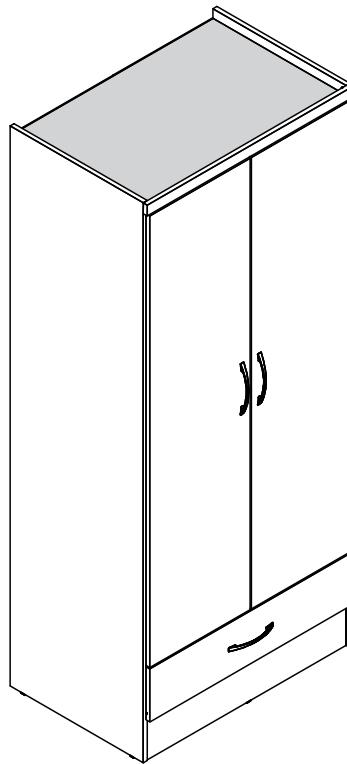

IMPORTANT FOR DOMESTIC USE ONLY

PLEASE READ BEFORE YOU CONTINUE FURTHER

CARE AND MAINTENANCE

After unpacking this product please keep the original packaging in case it needs to be returned for any reason.

- Please ensure all fittings and parts are present before commencing with assembly.
- Never drag or push products as this could cause damage to the joints making it inferior.
- We strongly recommend that you keep children away from your work area.
- We recommend that you lay a blanket or sheet on the floor to avoid damage to both your floor and the product.
- Assemble this product as close to its final position as possible.
- Do not place this product next to a radiator or in direct sunlight.
- Do not drag or push items across your high gloss furniture as this may cause the surface to scratch
- Wood is a natural product and may expand if subjected to damp and may shrink or crack if subjected to heat. Therefore it is recommended that room temperature is maintained, with no sudden temperature fluctuations.
- Make sure any spillage is wiped off immediately.
- Do not place hot or chilled items directly on to the surface, use a place mat or marking will occur.
- For general cleaning use a soft cotton or micro fibre cloth, and do not use detergents of any kind.
- From time to time it may be necessary to tighten fittings, regular inspections should be carried out.
- Do not place on a wet or damp floor as staining may occur to your floor.

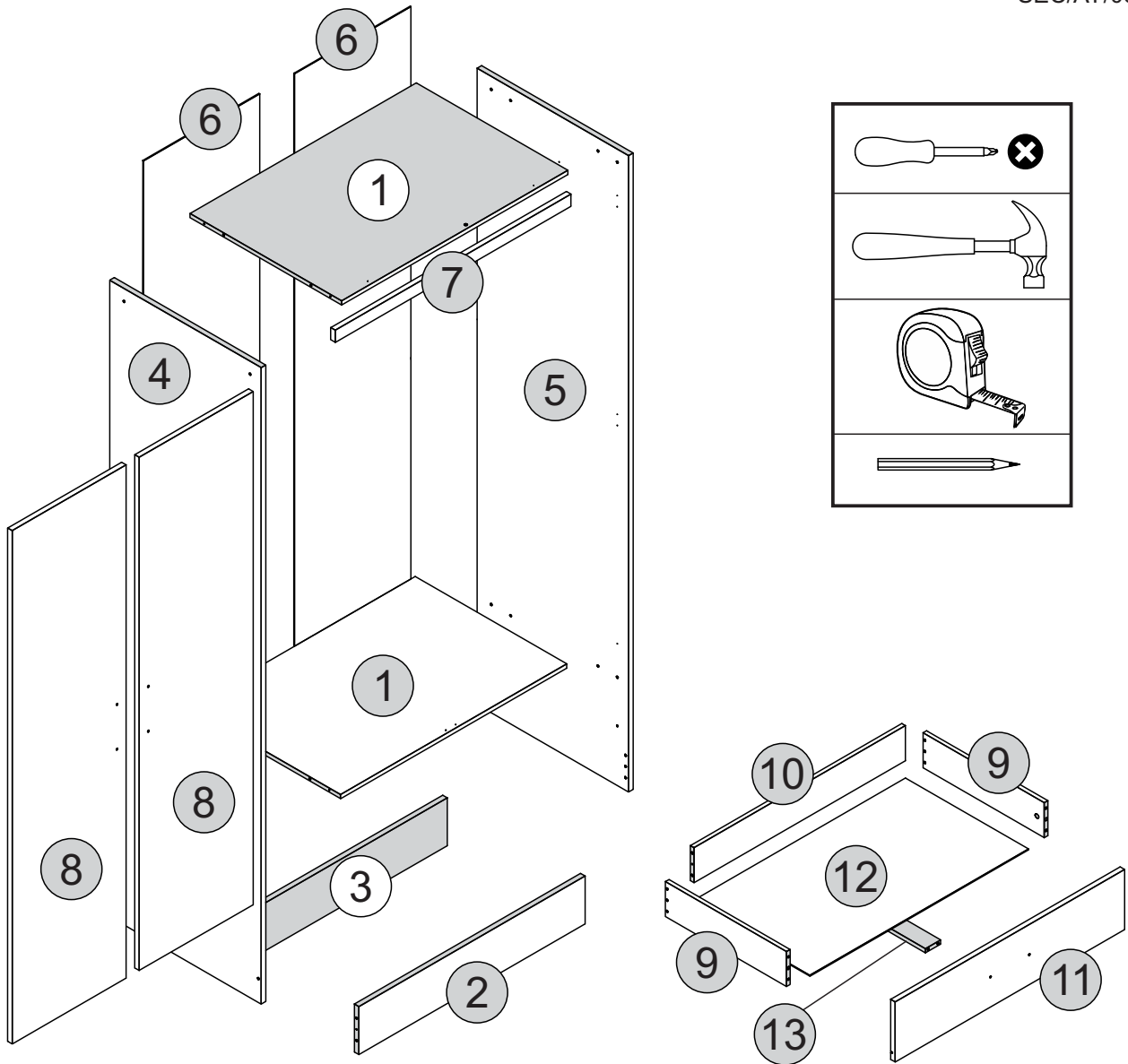







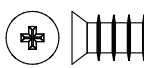
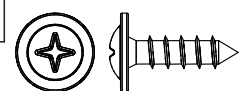
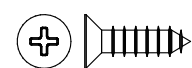
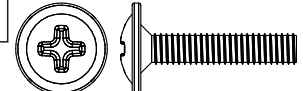

PARTS LIST

Please Note:
The below parts have all been stamped with the part number to help identify them during assembly.

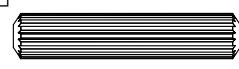
Part Number	Part Description	Quantity	Carton
01	Base-Top Panel	2	1/2
02	Front Baseboard	1	2/2
03	Back Baseboard	1	2/2
04	Left Side Panel	1	1/2
05	Right Side Panel	1	1/2
06	Back Panel	2	1/2
07	Frame	1	2/2
08	Door	2	2/2
09	Drawer Side	2	1/2
10	Drawer Back Panel	1	2/2
11	Drawer Front	1	2/2
12	Drawer Bottom	1	1/2
13	Drawer Botom Support Bar	1	1/2

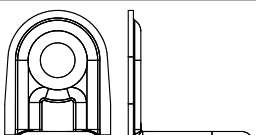
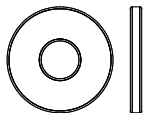
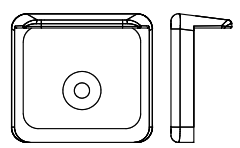
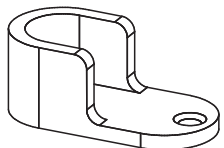
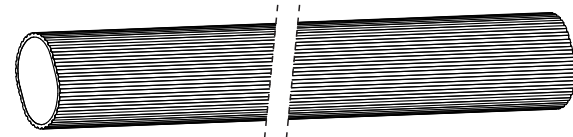
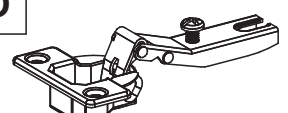
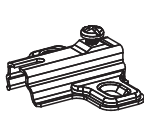
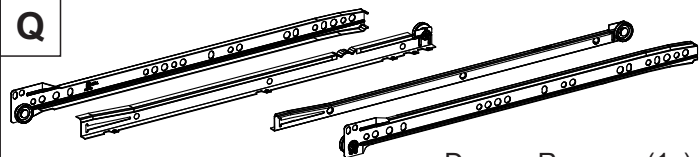
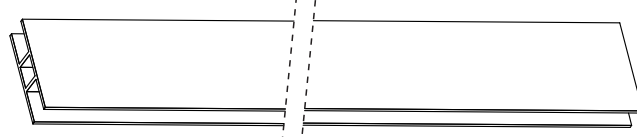
FITTINGS LIST

SEC/AY/06/21/CA7

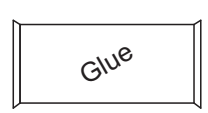
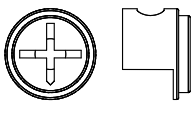
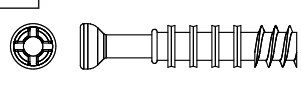
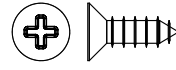
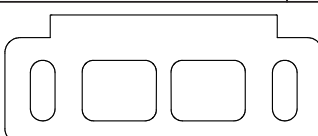
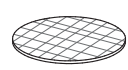
A  Flat Head Screw 1/+ Ø6,0 x 10mm (4x)	B  Flan Head Screw 1/+ Ø4,0 x 14mm (6x)	C  Flat Head Screw 2/+ Ø4,0 x 14mm (34x)	D  Flan Head Screw 1/+ Ø4,0 x 20mm (6x)
E  Flat Head Screw 1/+ Ø3,5 x 40mm (2x)	F  Flat Head Screw 2/+ Ø4,0 x 50mm (14x)	G  2/+ Dowel Ø6,0 x 30mm (26x)	
H  2/+ Nail 10 x 10 (58x)	I  1/+ Flan Head Screw Ø3,5 x 30mm (2x)	J  1/+ 'L' Metallic Support (4x)	K  1/+ Washer (4x)
L  1/+ Plastic Foot (6x)	M  Hanging Rail Support (2x)	N  Hanging Rail (1x)	
O  Hinge (6x)	P  Hinge Plate (6x)	Q  Drawer Runners (1x)	
R  Back Panel Strip (1x)	S  Strap (2x)	T  Handle (3x)	
U  2/+ Hole Plugs (12x)	V  Glue (1x)	W  1/+ Cam Nut (2x)	X  1/+ Cam Bolt (2x)
Y  Flat Head Screw 2/+ Ø4,0 x 12mm (12x)	Z  Door Support (2x)	A1  2/+ Hole Plugs (2x)	

TIPS FOR FITTINGS CAM-LOCKS

WHEN FITTING CAM NUT. ENSURE STARTING POSITION IS CORRECT BEFORE YOU INSERT CONNECTING CAM BOLT TURN CLOCKWISE UNTIL SECURE

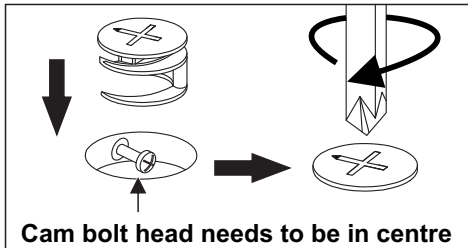
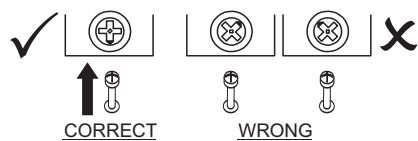

CAMBOLT
 Tighten until shoulder in flush with panel. Do not overtighten or undertighten (see example beside)

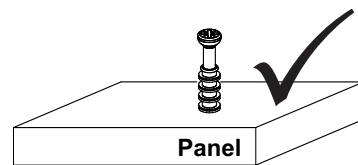
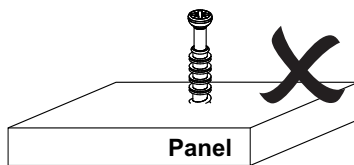
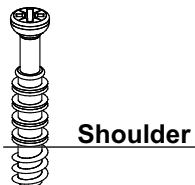

STEP 1

PARTS REQUIRED

4 - LEFT SIDE PANEL x1

HARDWARE REQUIRED

A  02
Ø6,0 x 10mm

H  02
10 x 10

L  02

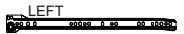
Q  LEFT 01

TOOLS REQUIRED

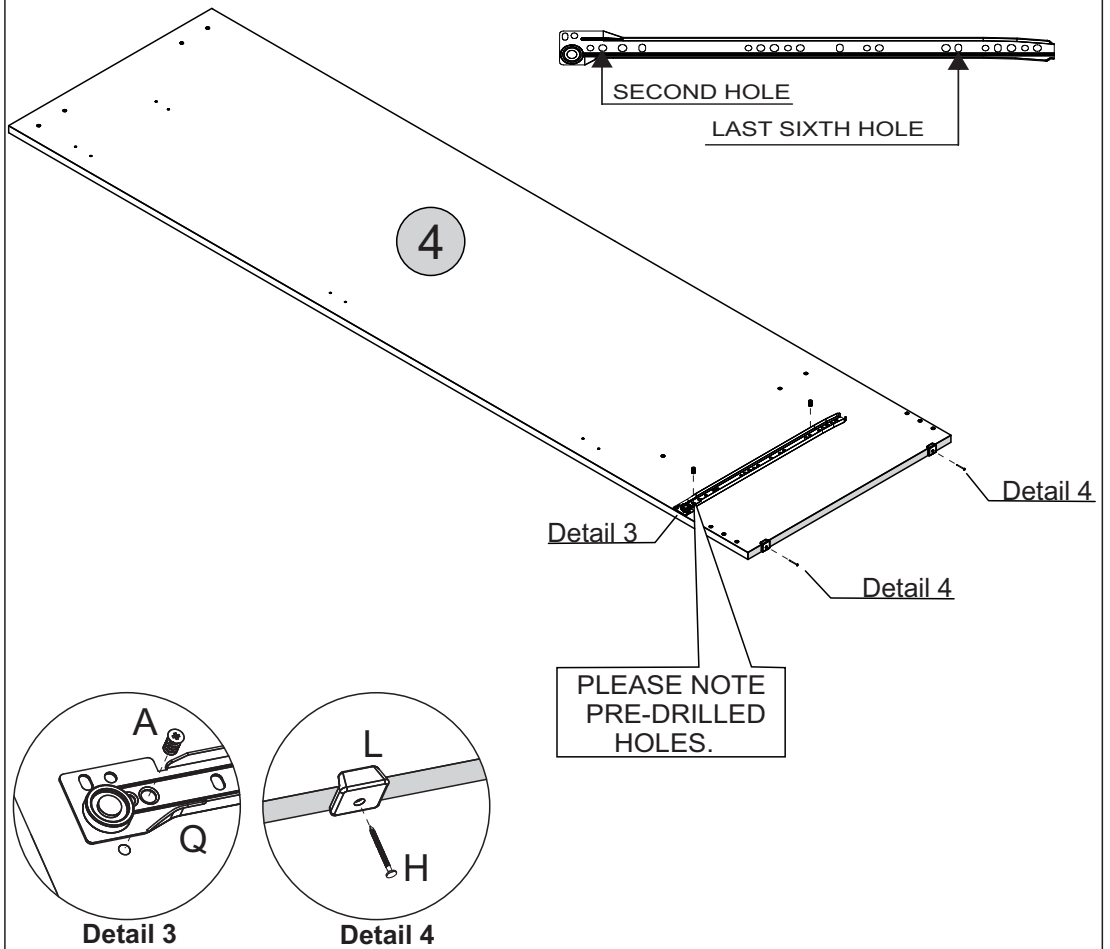
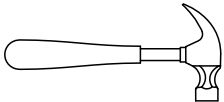
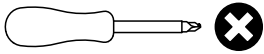



STEP 2

PARTS REQUIRED

4 - RIGHT SIDE PANEL x1

HARDWARE REQUIRED

A  02
Ø6,0 x 10mm

H  02
10 x 10

L  02

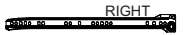
Q  RIGHT 01

TOOLS REQUIRED

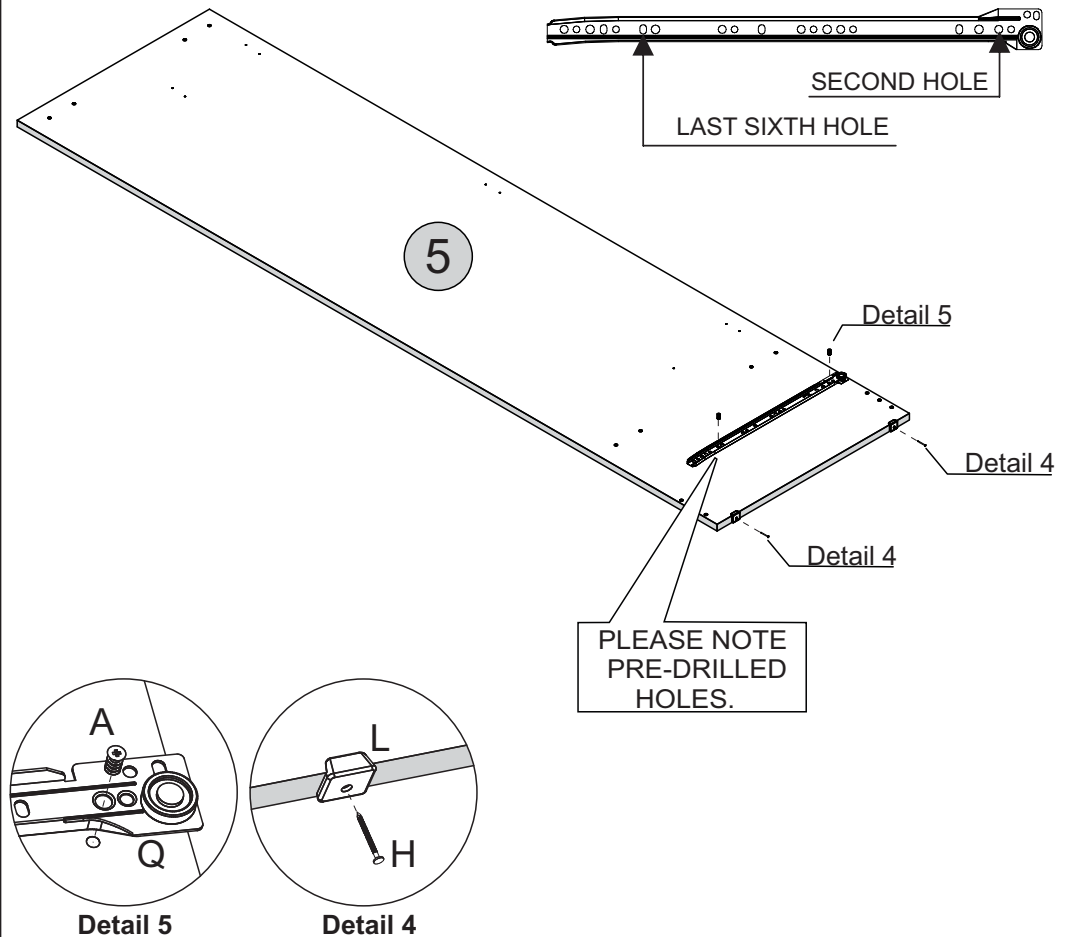
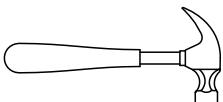
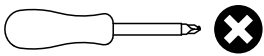

STEP 3

PARTS REQUIRED

4 - LEFT SIDE PANEL x1

HARDWARE REQUIRED

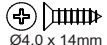
C  08
Ø4,0 x 14mm

M  01

P  03

TOOLS REQUIRED

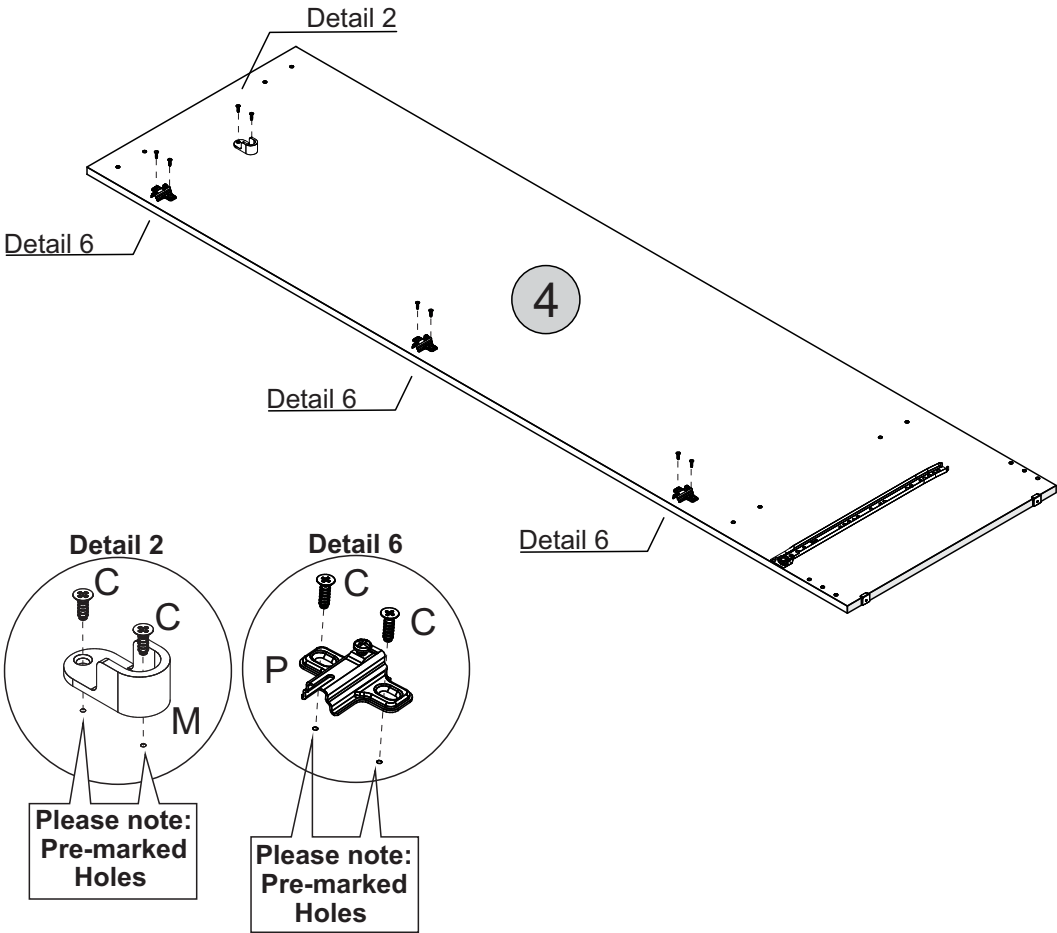
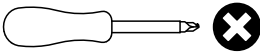



STEP 4

PARTS REQUIRED

4 - RIGHT SIDE PANEL x1

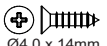
HARDWARE REQUIRED

C  08
Ø4,0 x 14mm

M  01

P  03

TOOLS REQUIRED

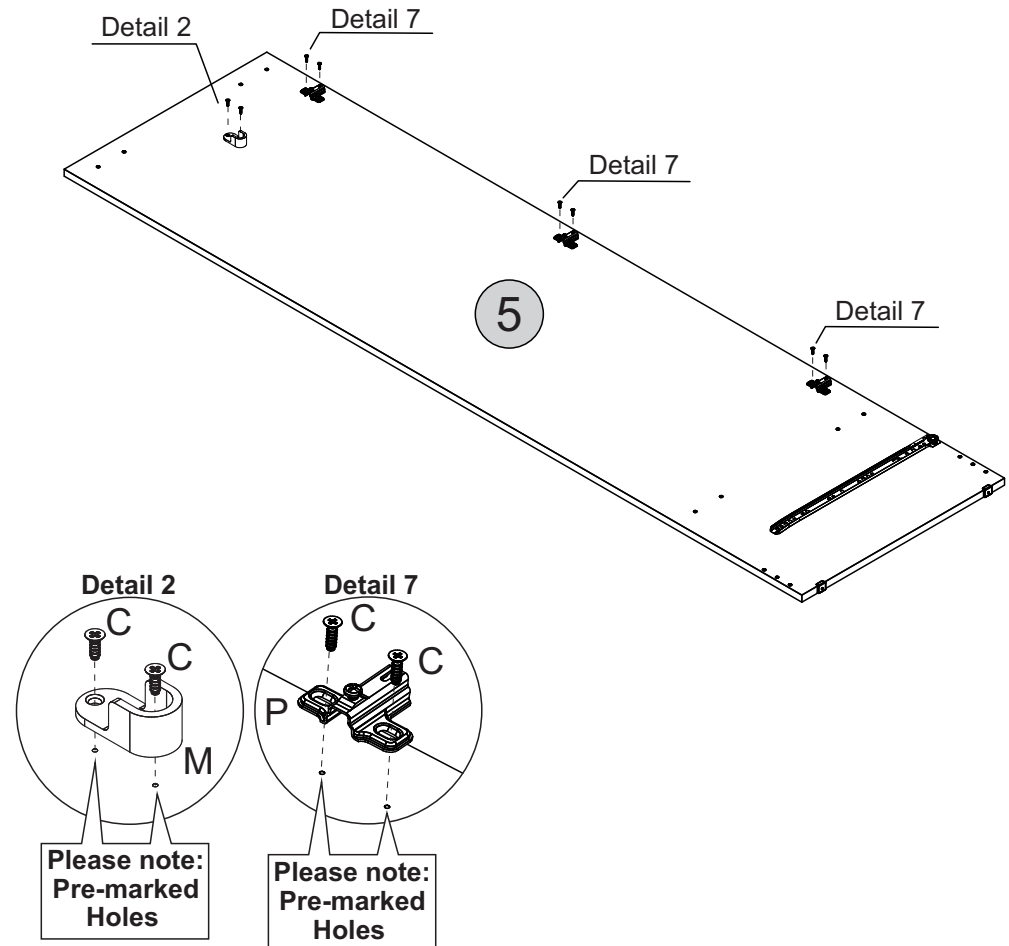
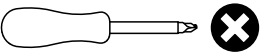

STEP 5

PARTS REQUIRED

1A - TOP PANEL x1

1B - BASE PANEL x1

HARDWARE REQUIRED

G  08
Ø6,0 x 30mm

J  02

V  01

Y  06
Ø4,0 x 12mm

Z  02

TOOLS REQUIRED

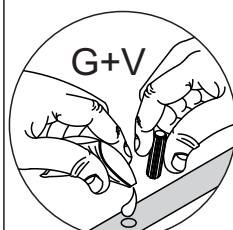
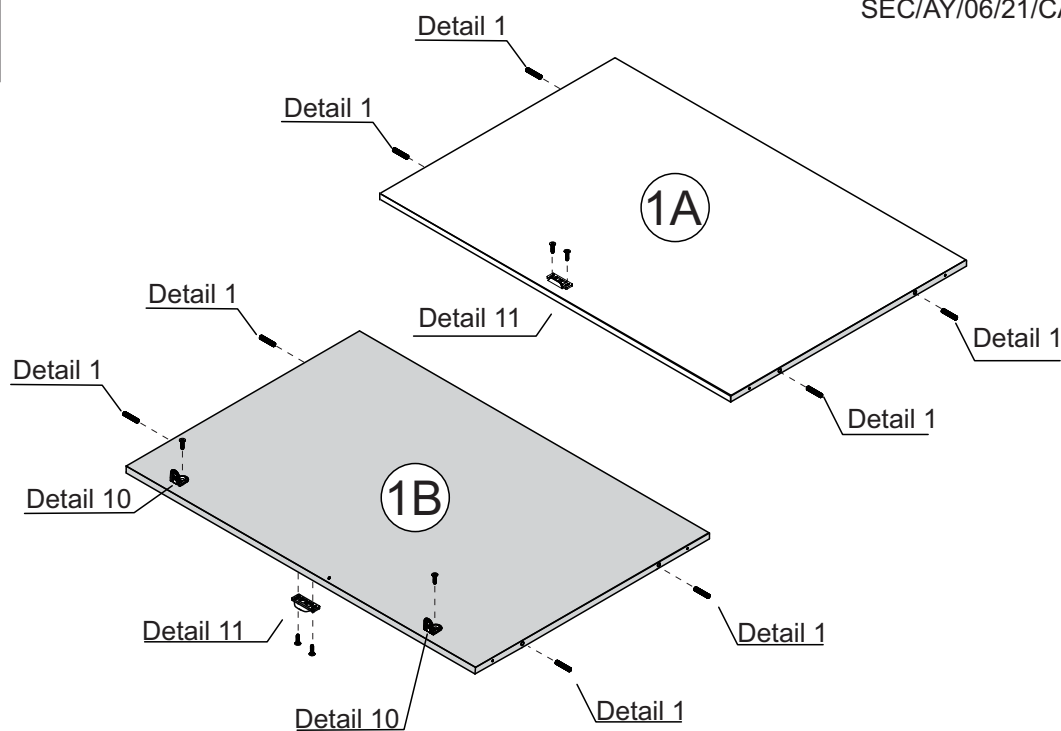
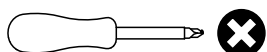

Detail 1

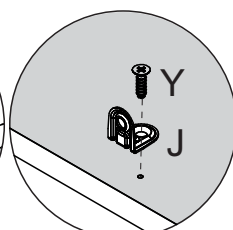

Detail 10

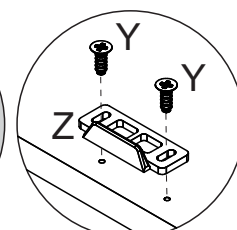

Detail 11

STEP 6

PARTS REQUIRED

2 - FRONT BASEBOARD x1

3 - BACK BASEBOARD x1

HARDWARE REQUIRED

G  08
Ø6,0 x 30mm

H  02
10 x 10

L  02

V  01

TOOLS REQUIRED

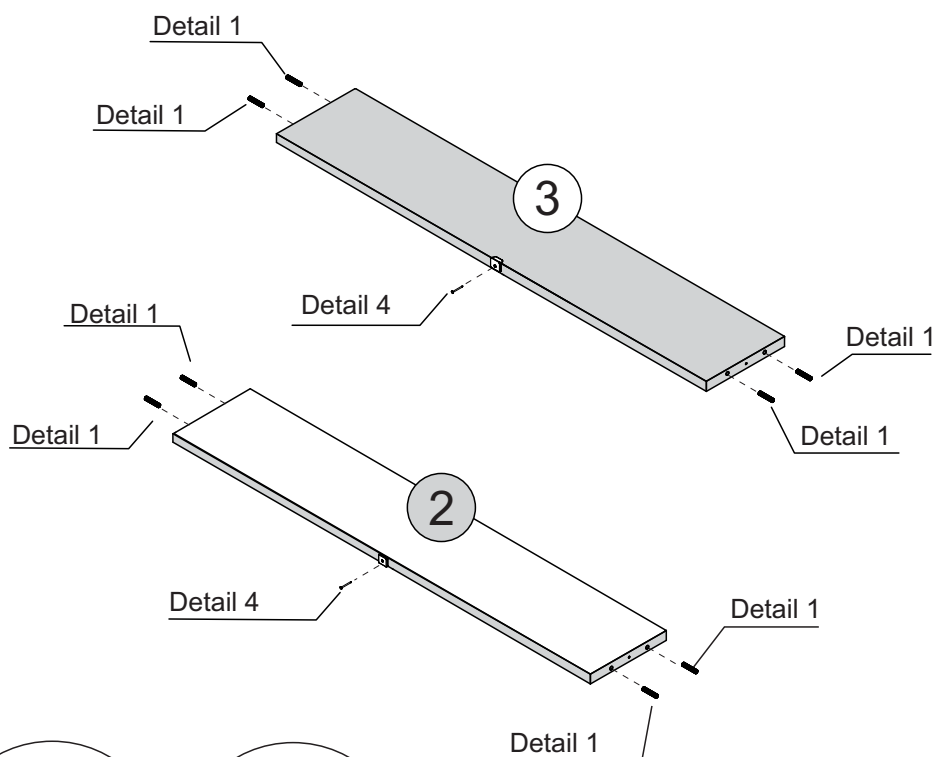
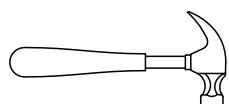

Detail 1

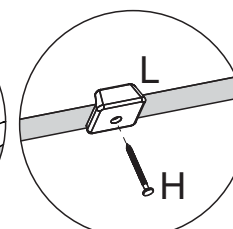

Detail 4

STEP 7

PARTS REQUIRED

1A - BASE PANEL x1

1B - TOP PANEL x1

5 - RIGHT SIDE PANEL x1

HARDWARE REQUIRED

F  04
Ø4,0 x 50mm

V  01

TOOLS REQUIRED

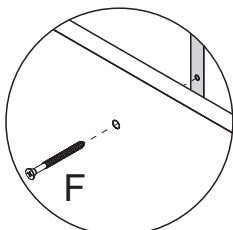
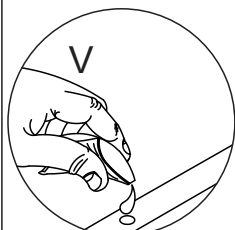
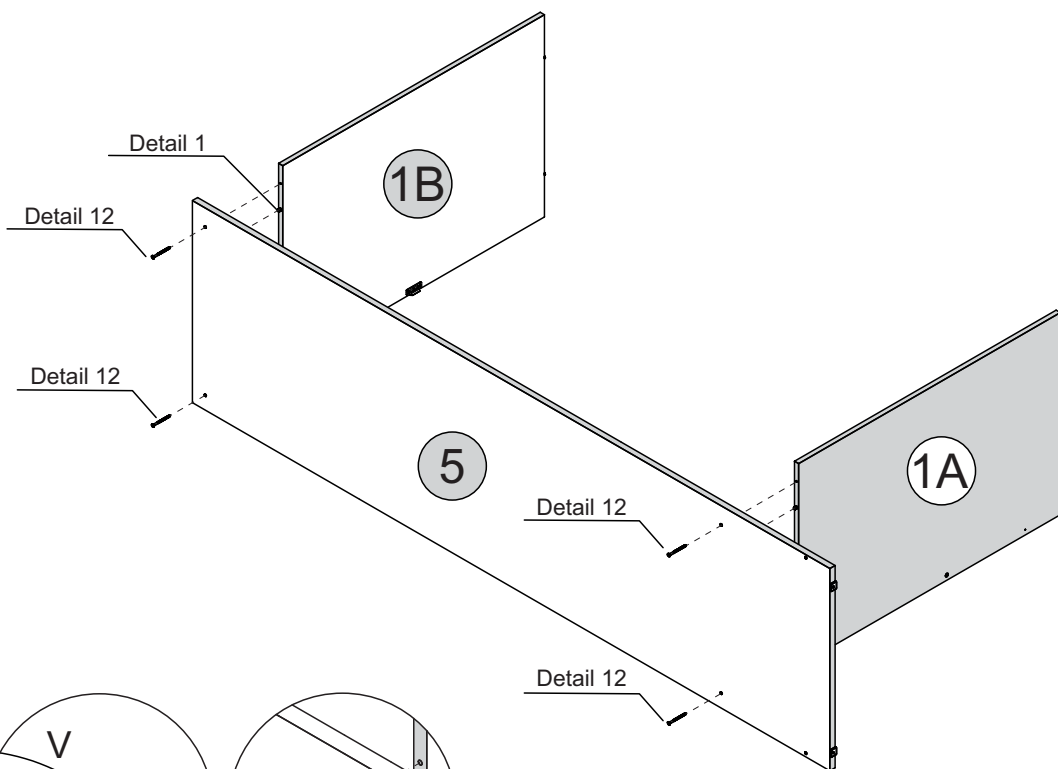
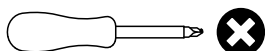

Detail 1

Detail 12

STEP 8

PARTS REQUIRED

2 - FRONT BASEBOARD x1

3 - BACK BASEBOARD x1

4 - LEFT SIDE PANEL x1

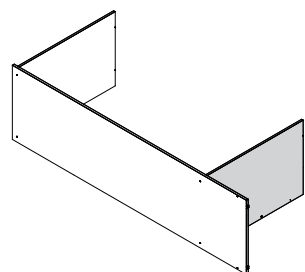

HARDWARE REQUIRED

F  08
Ø4,0 x 50mm

V  01

TOOLS REQUIRED

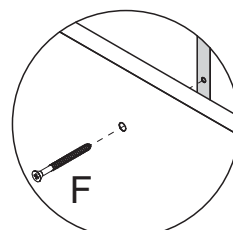
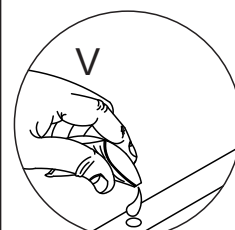
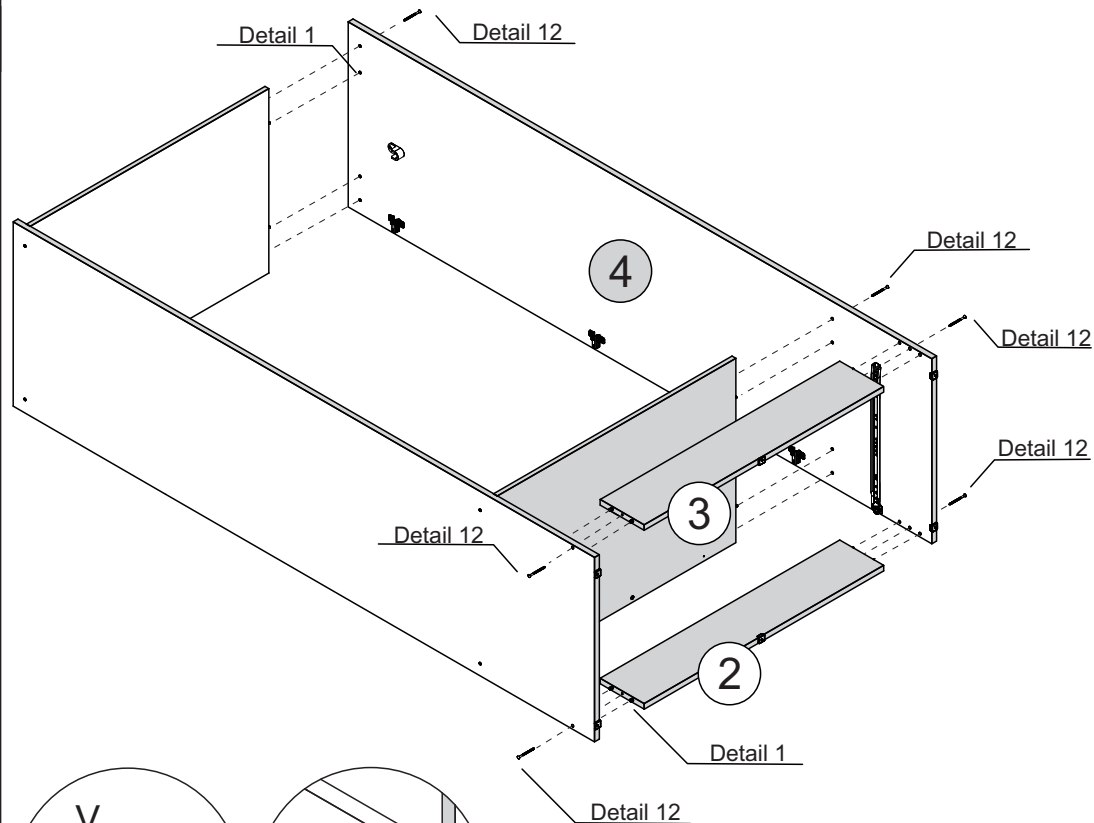
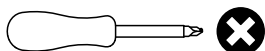

Detail 1

Detail 12

STEP 9

SEC/AY/06/21/CA7

PARTS REQUIRED

6 - BACK PANEL x2

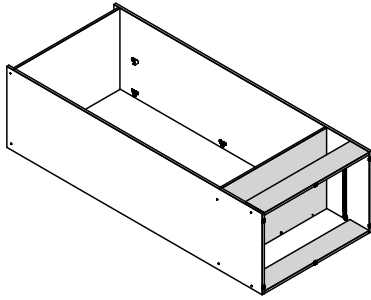

HARDWARE REQUIRED

H  40

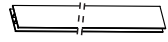
R  01

TOOLS REQUIRED

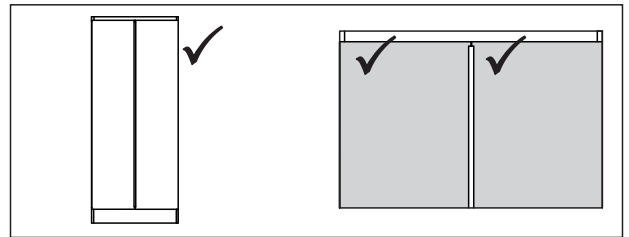
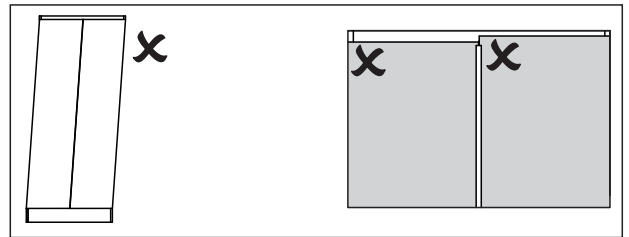
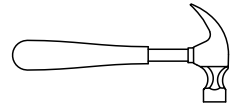

* For your future reference
Order Number should be here

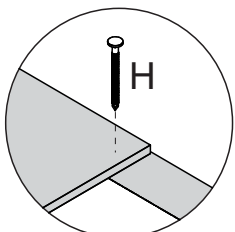
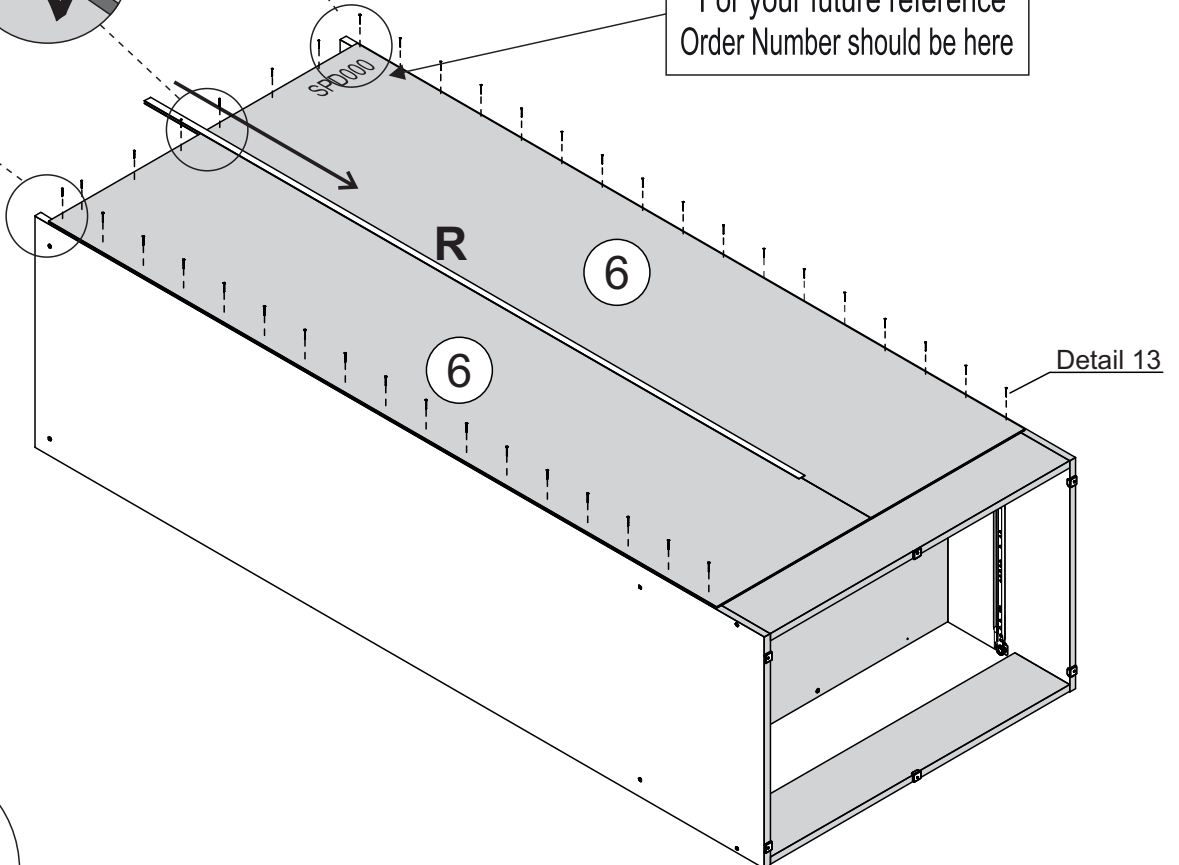
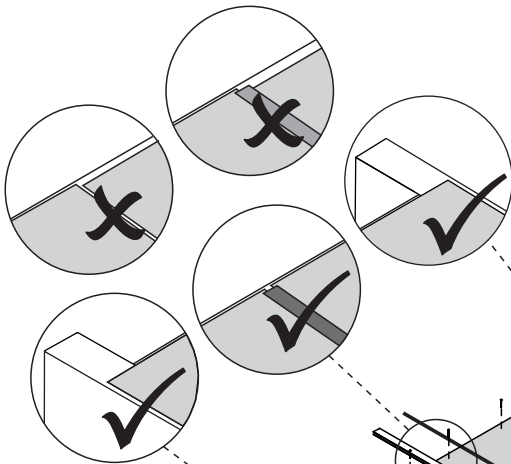

Detail 13

STEP 10

SEC/AY/06/21/CA7

PARTS REQUIRED

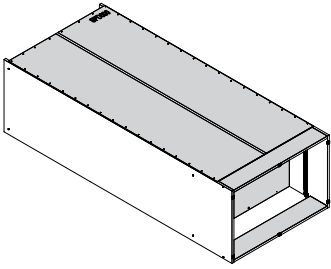

HARDWARE REQUIRED

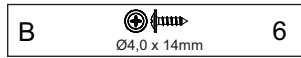
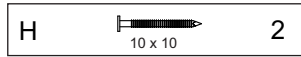

TOOLS REQUIRED

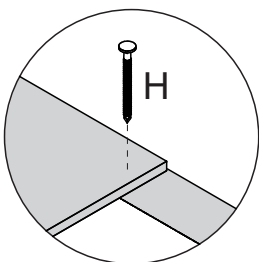
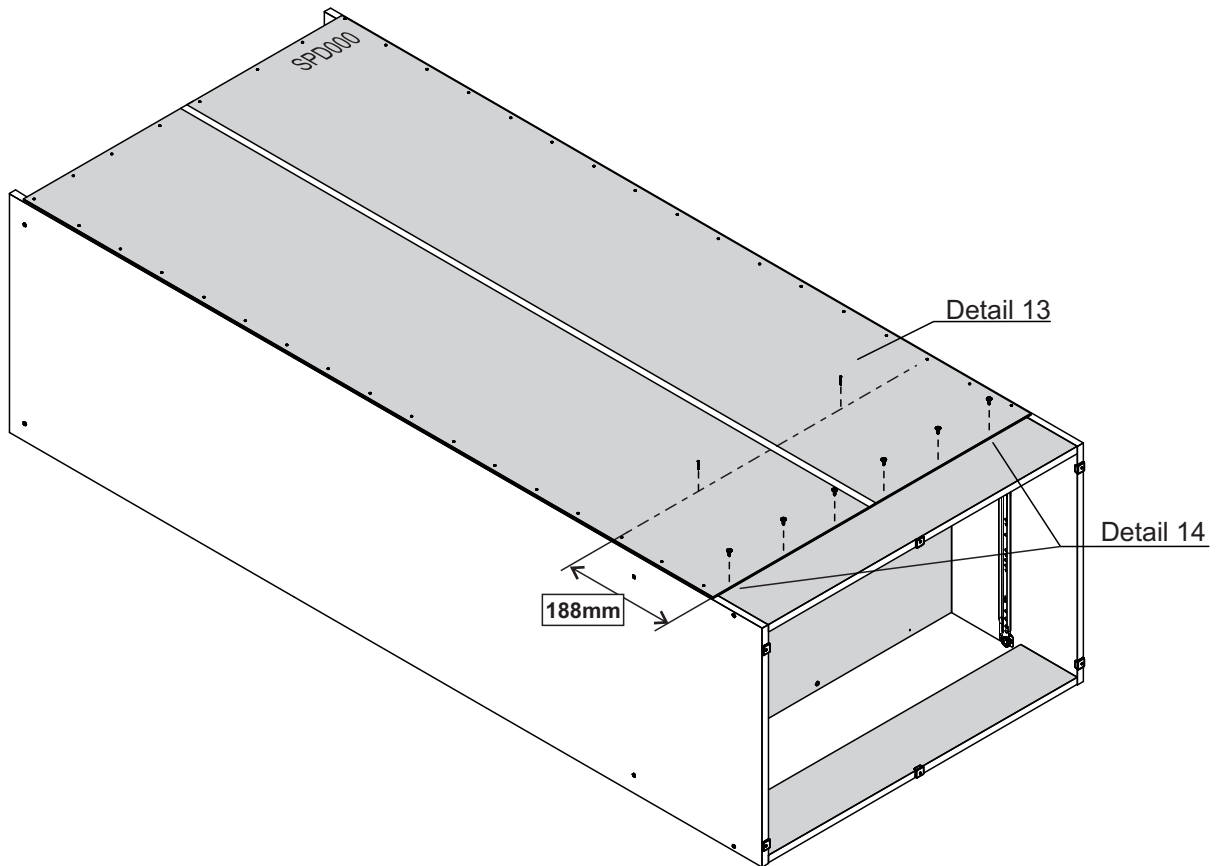
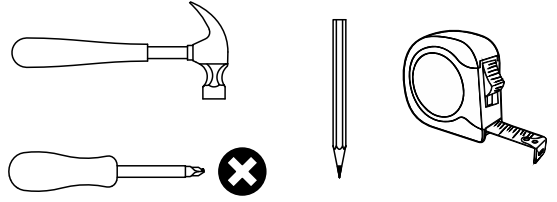

Detail 13

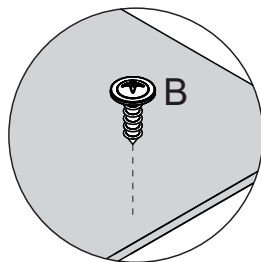

Detail 14

STEP 11

PARTS REQUIRED

7 - FRAME x1

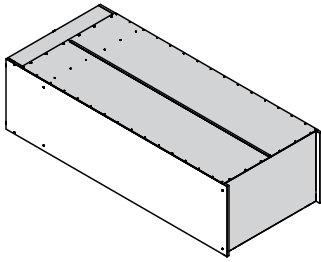

HARDWARE REQUIRED

J  02

Y  06
Ø4,0 x 12mm

TOOLS REQUIRED

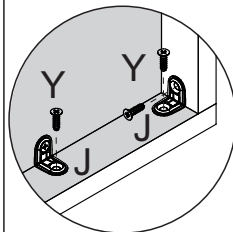
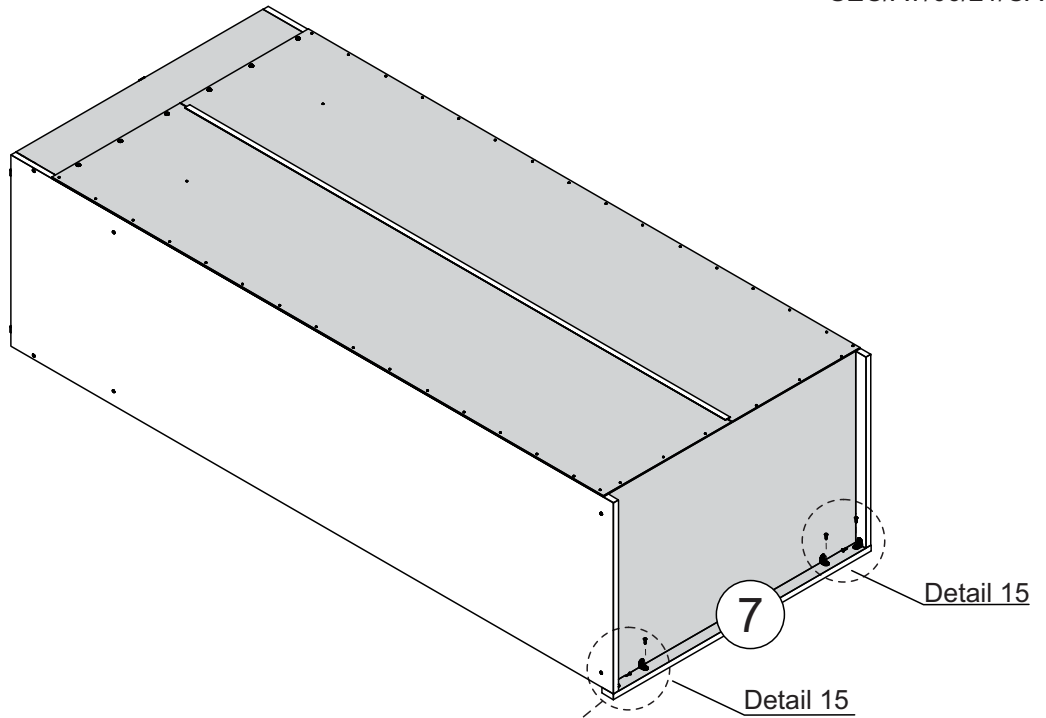
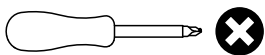

Detail 15

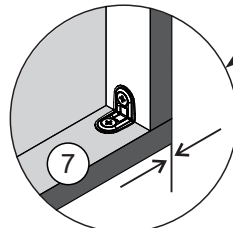

Align corners

STEP 12

PARTS REQUIRED

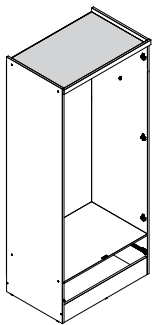

HARDWARE REQUIRED

N  01

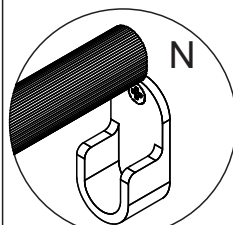
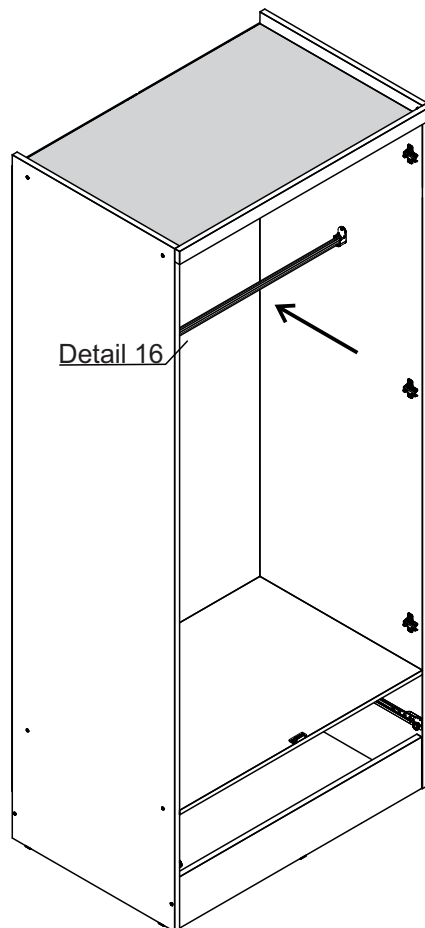

Detail 16

STEP 13

PARTS REQUIRED

9 - DRAWER SIDE x2

10 - DRAWER BACK PANEL x1

13 - DRAWER BOTTOM SUPPORT BAR x1

HARDWARE REQUIRED

G  10
Ø6,0 x 30mm

V  01
Glue

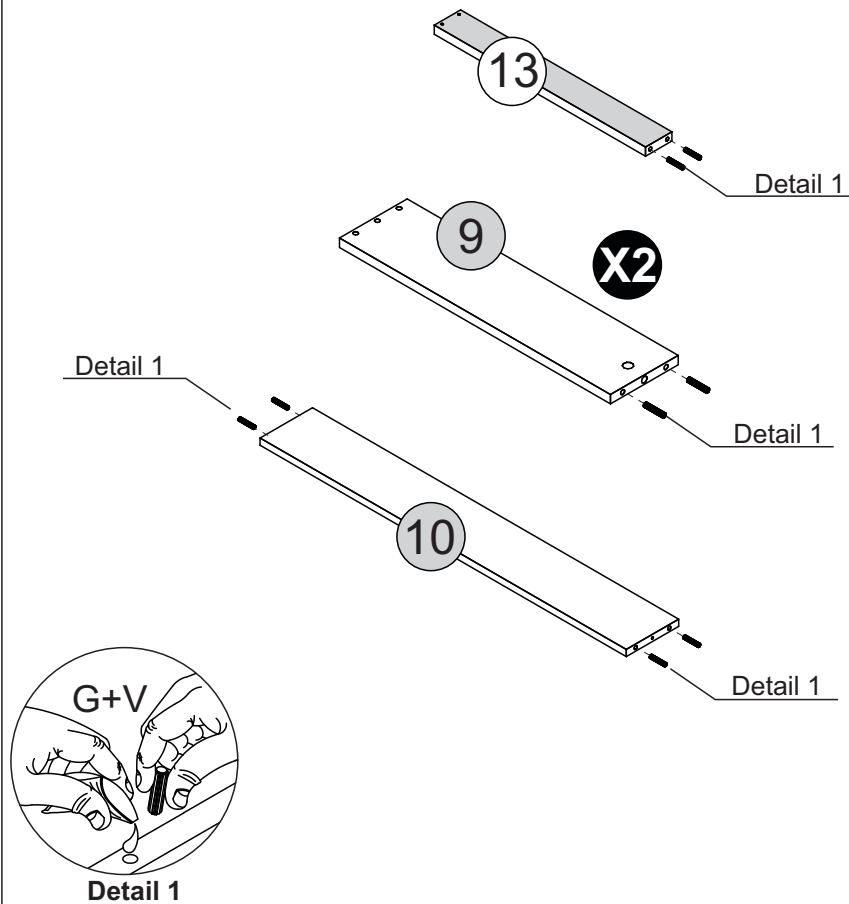

STEP 14

PARTS REQUIRED

11 - DRAWER FRONT x1

HARDWARE REQUIRED

X  02

TOOLS REQUIRED

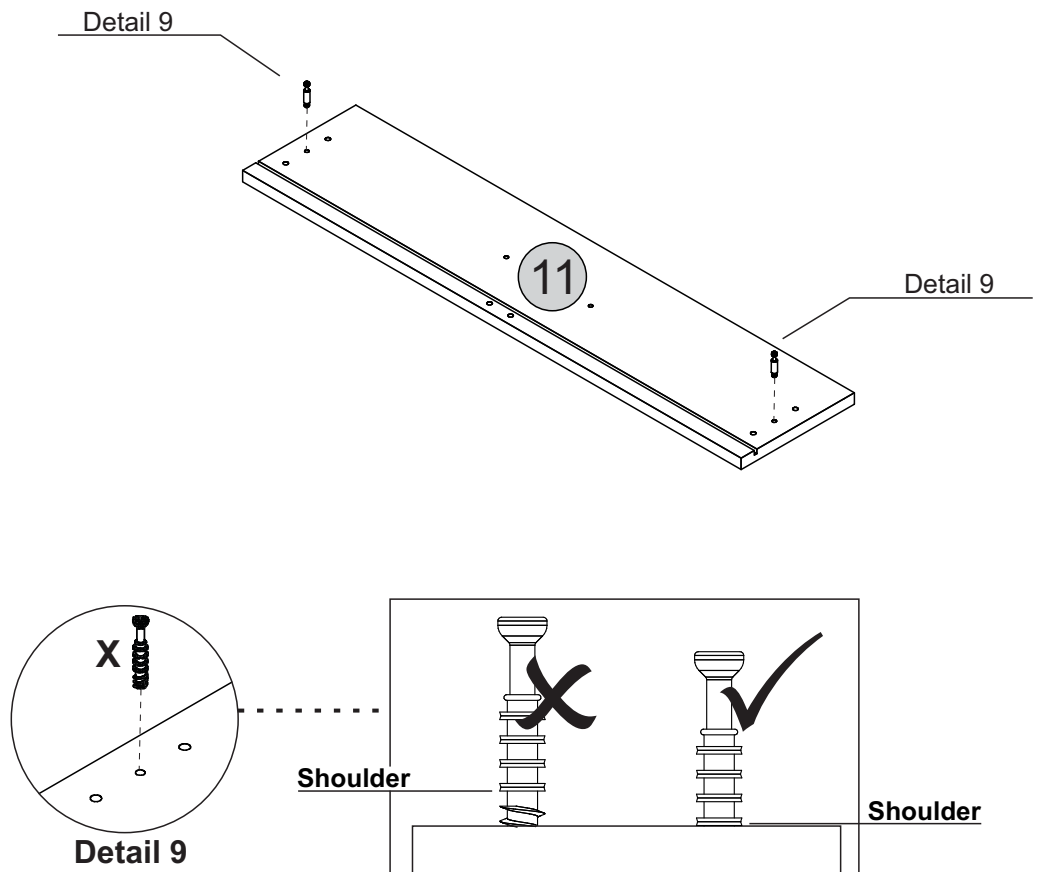
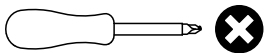

STEP 15

PARTS REQUIRED

9 - DRAWER SIDE x2

10 - DRAWER BACK PANEL x2

HARDWARE REQUIRED

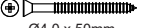
F  02
Ø4,0 x 50mm

TOOLS REQUIRED

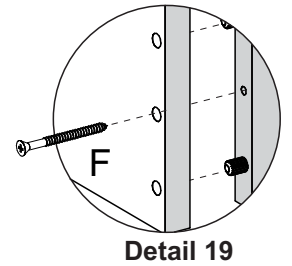
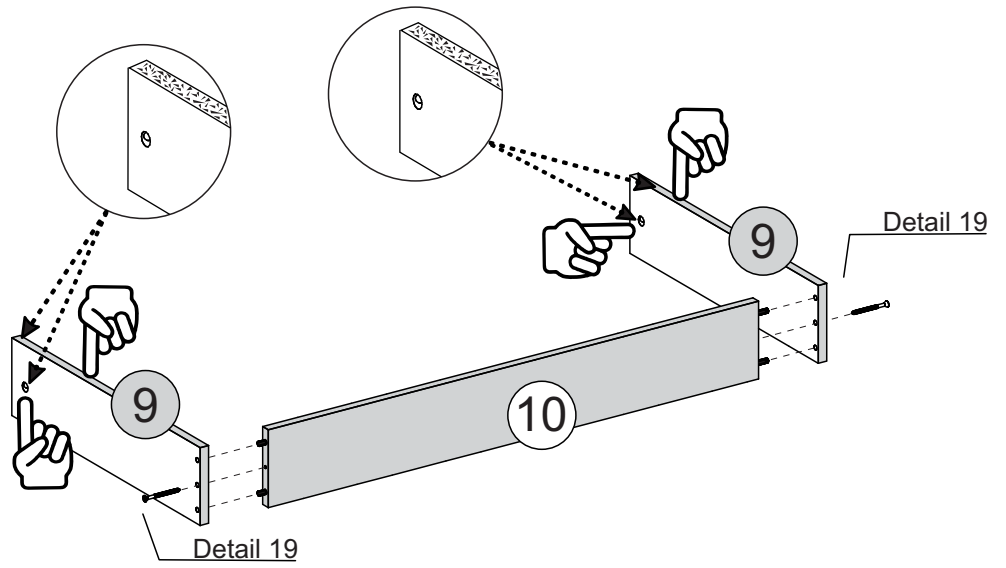
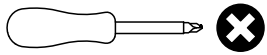

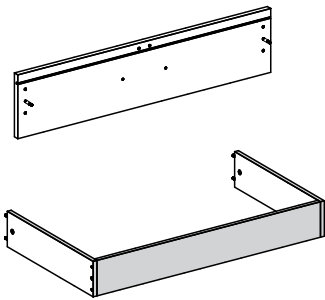

STEP 16

PARTS REQUIRED



HARDWARE REQUIRED

A1  02

V  01

W  02

TOOLS REQUIRED

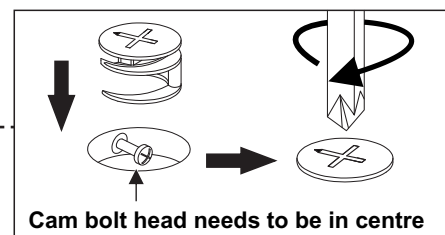
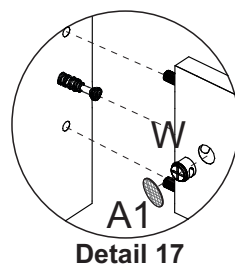
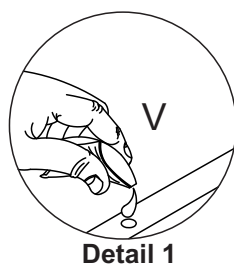
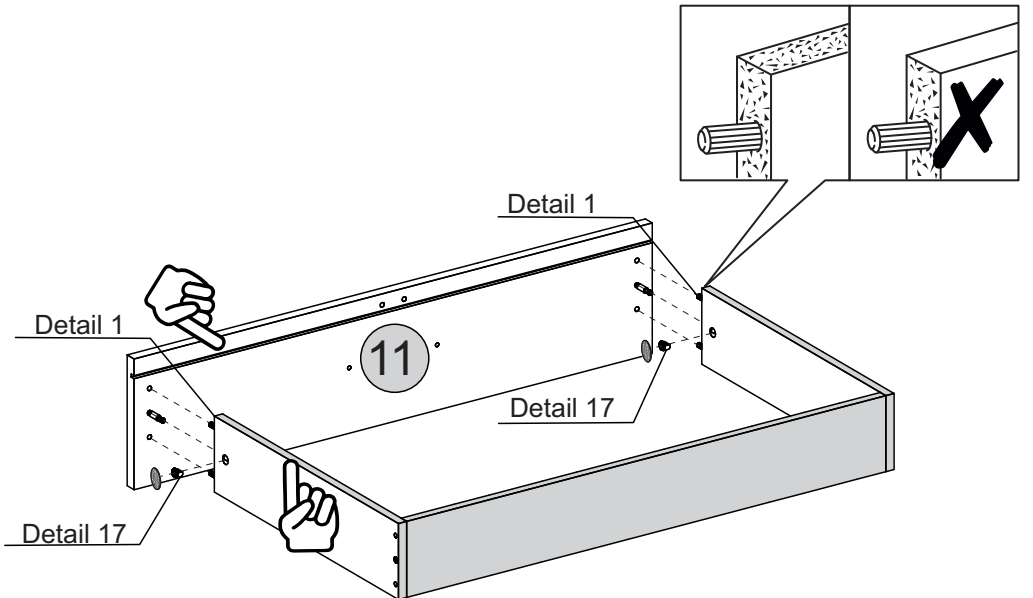
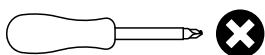

STEP 17

PARTS REQUIRED

12 - DRAWER BOTTOM x1

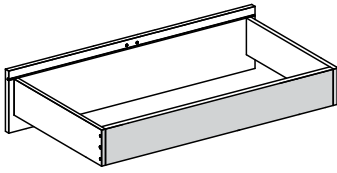

HARDWARE REQUIRED

H  04
10 x 10

TOOLS REQUIRED

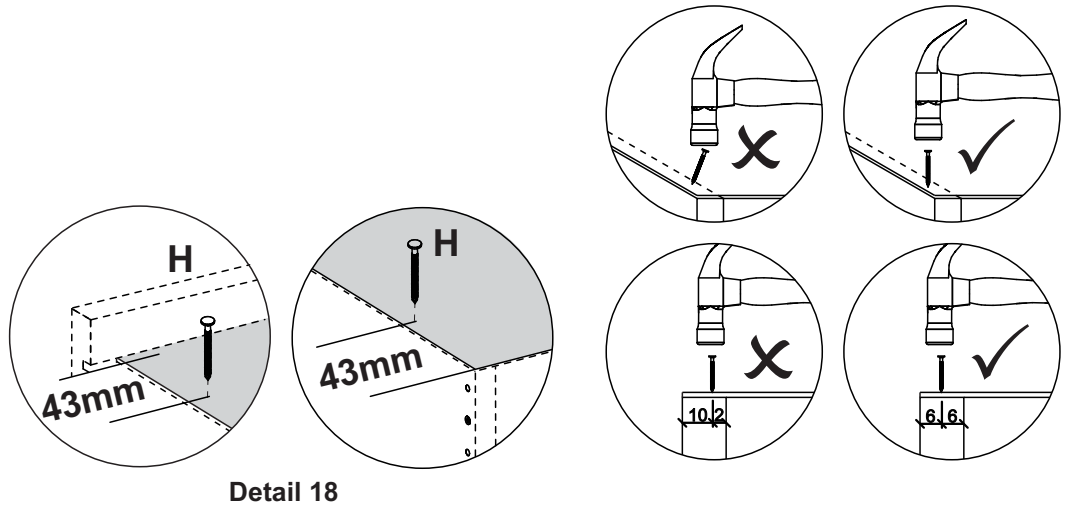
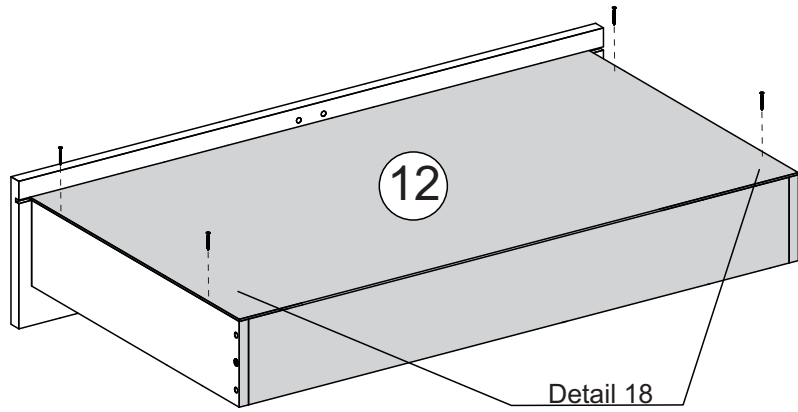
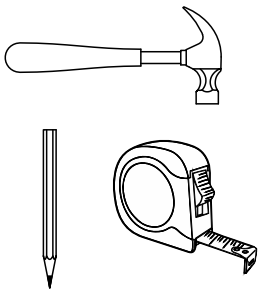

STEP 18

PARTS REQUIRED

13 - DRAWER BOTTOM SUPPORT BAR x1

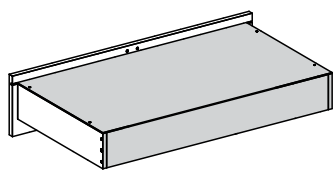

HARDWARE REQUIRED

H  06
10 x 10

TOOLS REQUIRED

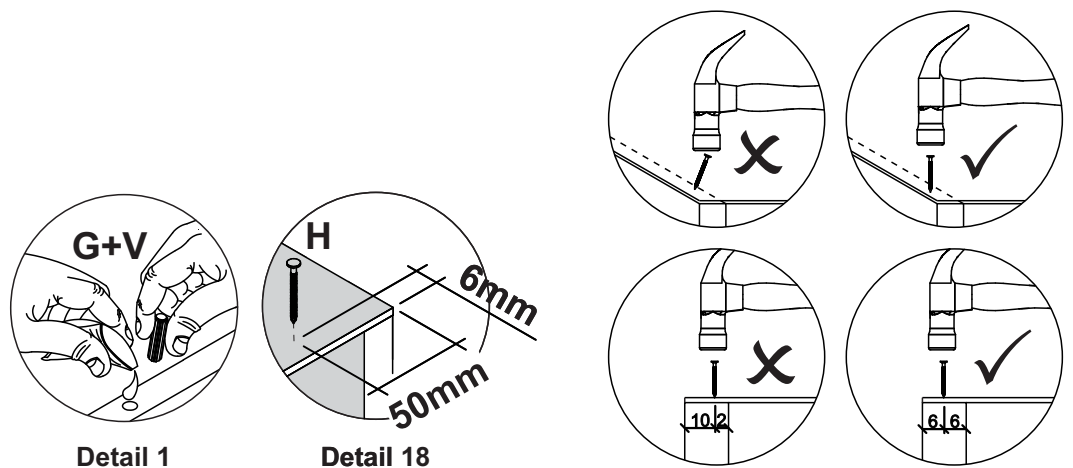
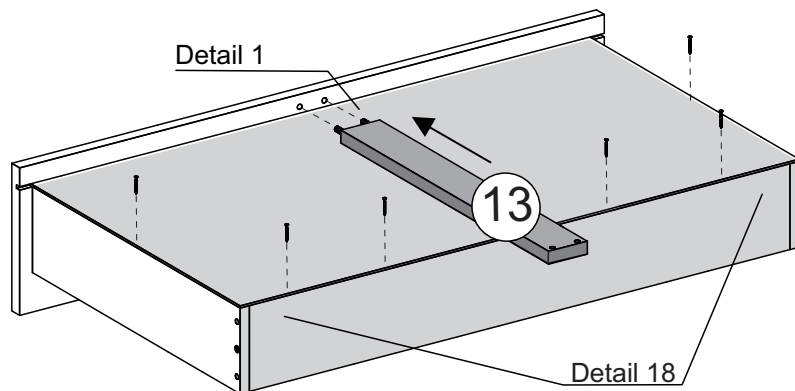
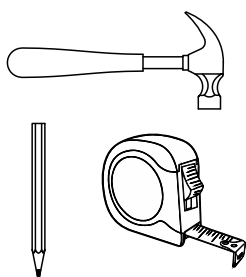

STEP 19

PARTS REQUIRED

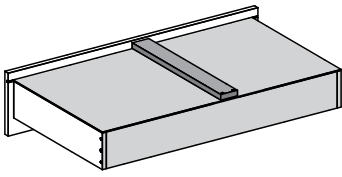

HARDWARE REQUIRED

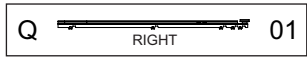
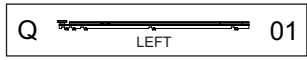
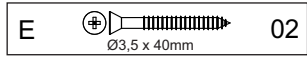
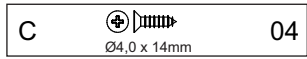

TOOLS REQUIRED

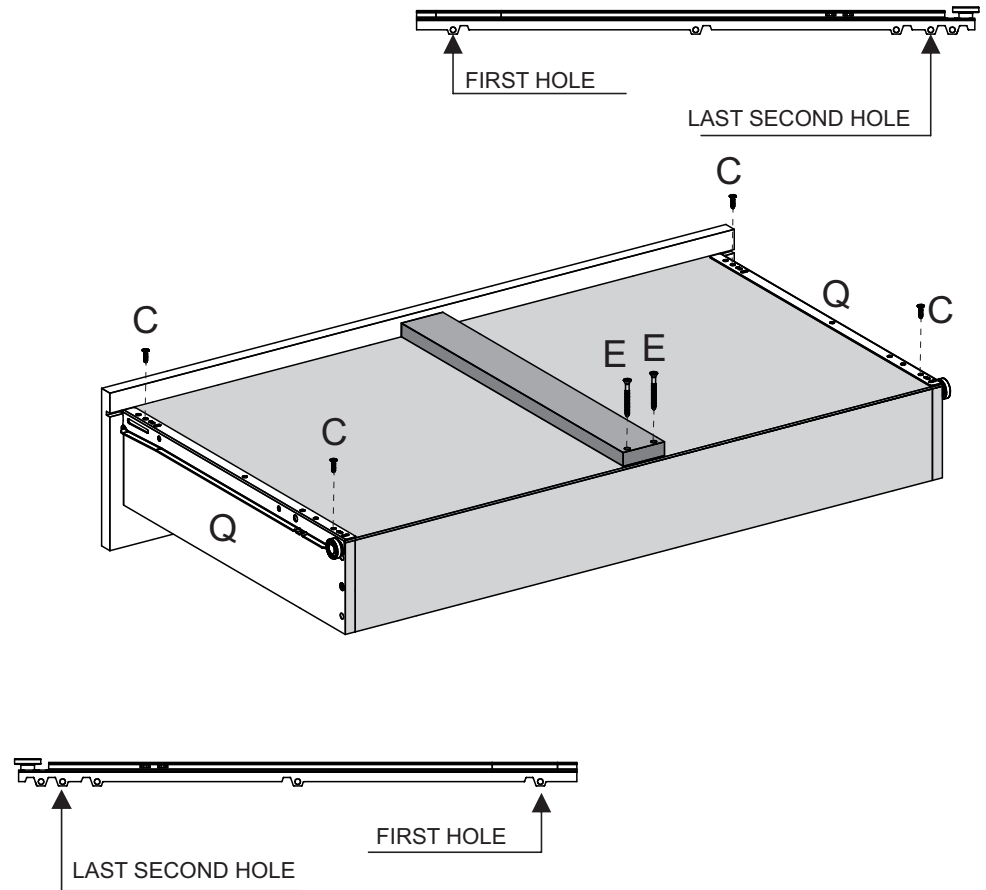
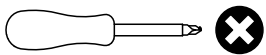

STEP 20

PARTS REQUIRED

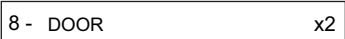

HARDWARE REQUIRED

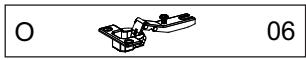
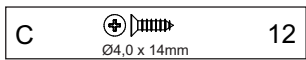

TOOLS REQUIRED

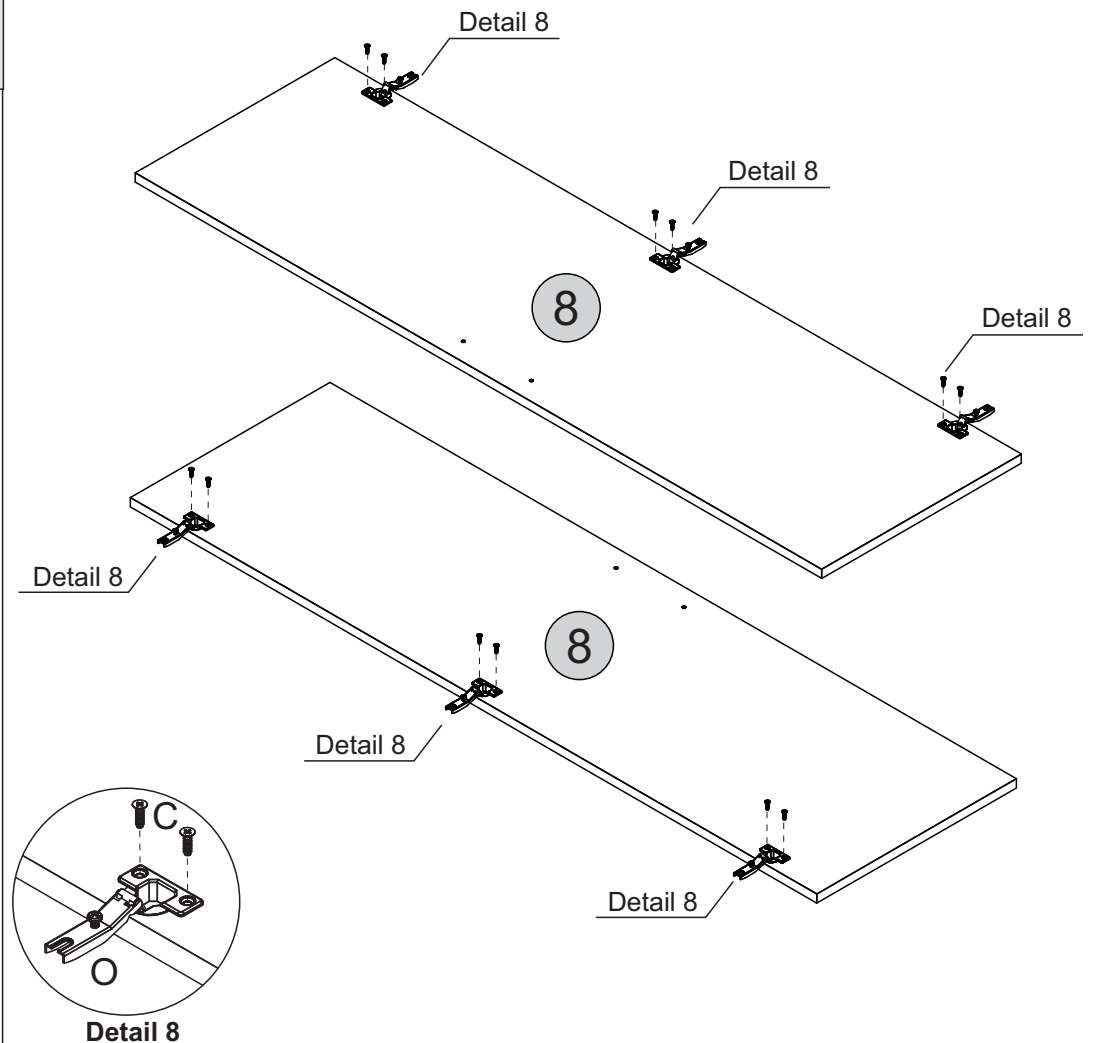
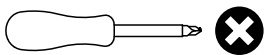

STEP 21

PARTS REQUIRED

8 - DOOR x2

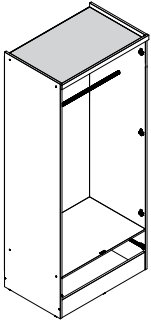

HARDWARE REQUIRED

U  12

TOOLS REQUIRED

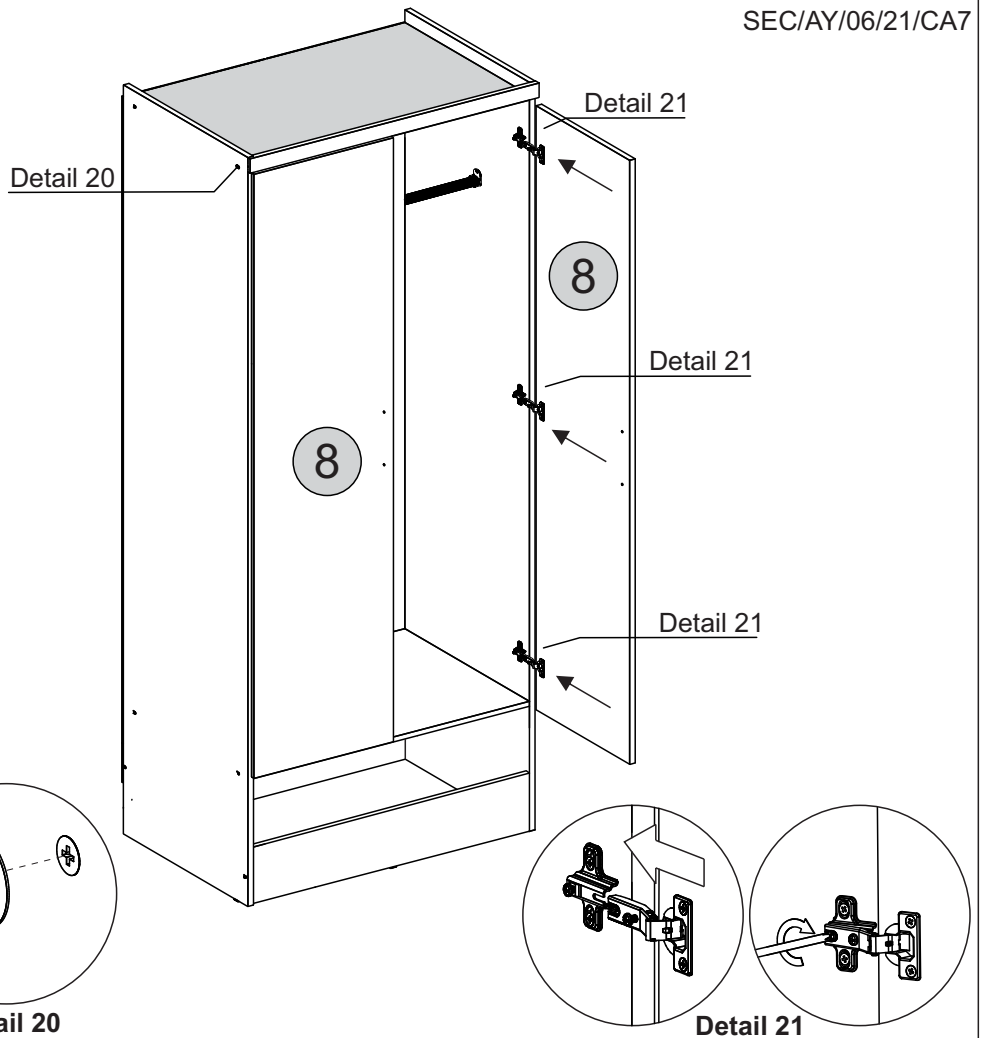
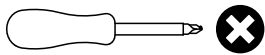

STEP 22

PARTS REQUIRED

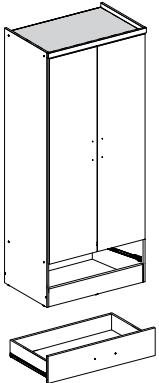

HARDWARE REQUIRED

D  06
Ø4,0 x 20mm

T  03

TOOLS REQUIRED

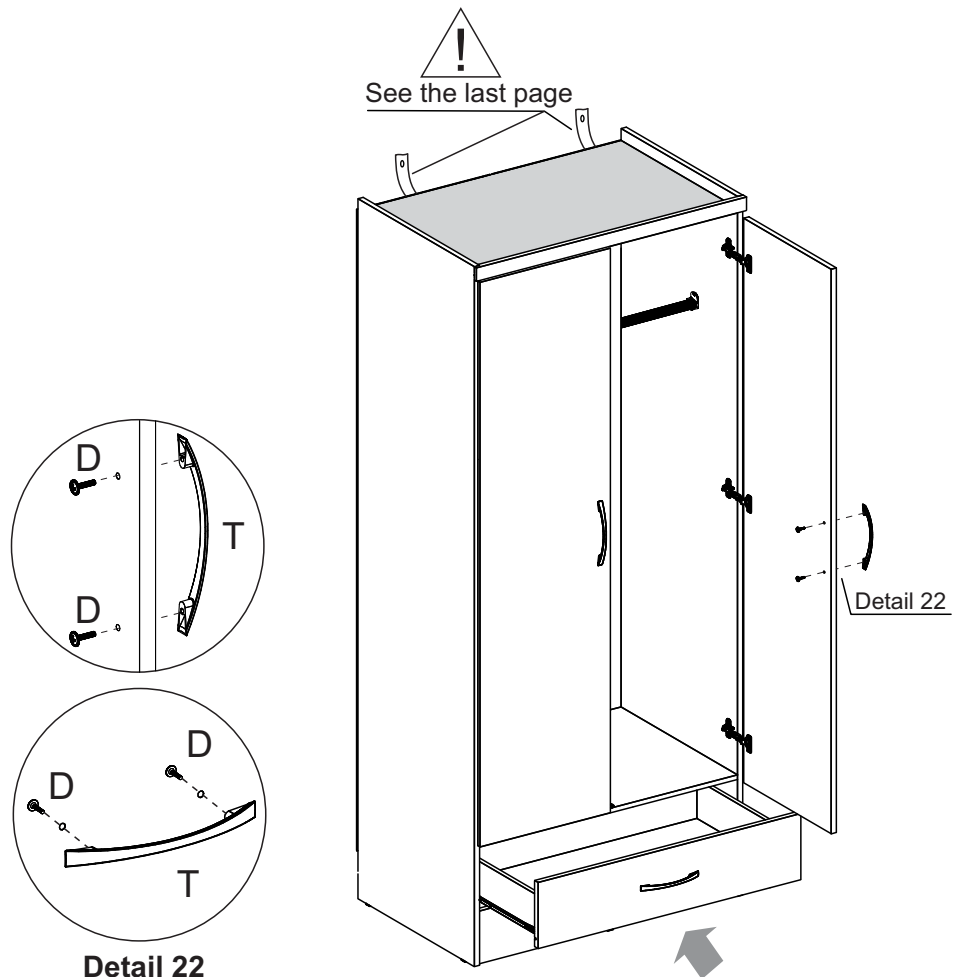
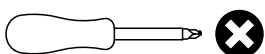

STEP 23

SEC/AY/06/21/CA7

PARTS REQUIRED

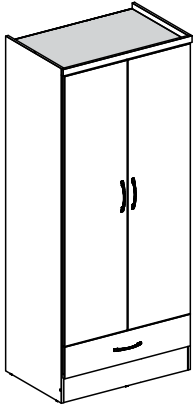

HARDWARE REQUIRED

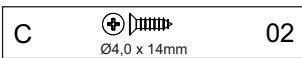

TOOLS REQUIRED

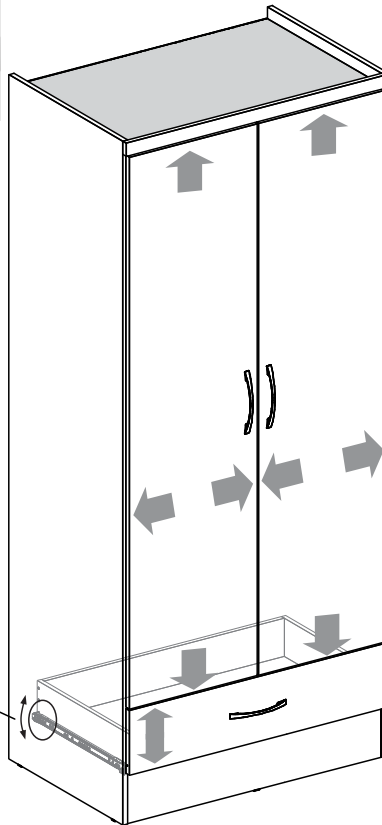
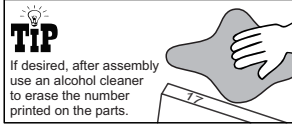
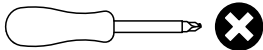

Detail 23

Height Adjustment

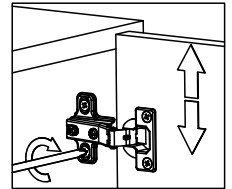

Internal Adjustment

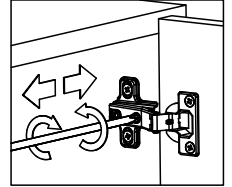

Depth Adjustment

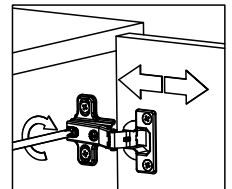
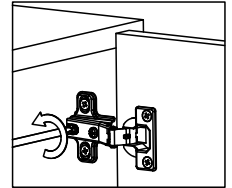

Drawer Adjustment Drawer Lock

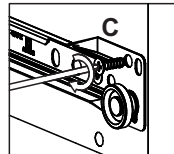
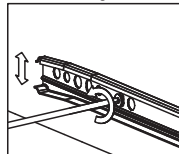

Detail 23

WARNING

Serious or fatal injuries can occur from furniture tipping over. To prevent the furniture from tipping over we recommend that it is permanently fixed to the wall.

Wall fixings are not supplied with this product as different wall materials require different types of fixing devices.

Please make sure you use fixings suitable for the walls in your home.

